

UNITED STATES DEPARTMENT OF AGRICULTURE

DEPARTMENT CIRCULAR 379

Washington, D. C.

July, 1926

THE USE OF SALT IN RANGE MANAGEMENT

W. R. CHAPLINE

Inspector of Grazing

and

M. W. TALBOT

Formerly Grazing Examiner

Forest Service

CONTENTS

Page		Page
Salt in the ration of livestock-----	2	Salting on cattle and horse ranges—
The need and effect of feeding salt-----	2	Continued.
The salt content of feeds-----	3	Location of salt grounds-----
Salt in drinking waters and alkali licks-----	4	Number of salting places-----
Proper allowance of salt for range livestock-----	5	Salt allowance for each ground-----
Kinds and grades of salt to use-----	6	Marking salting places-----
Losses by weathering-----	7	Distributing the salt to the range-----
The economy of salt containers-----	8	Handling the cattle on the range-----
Construction of salt containers-----	9	Duties of the rider-----
Salt storage-----	11	Salting plans for national-forest ranges-----
Salting on cattle and horse ranges-----	11	Salting on sheep and goat ranges-----
Salting to obtain local distribution of cattle-----	12	Summary-----
Salting to obtain seasonal distribution of cattle-----	14	Literature cited-----

With an adequate quantity of salt, grazing animals develop better than they would otherwise, are more contented, and are more easily handled (fig. 1). Also, proper quantity and distribution of salt on the range go a long way toward controlling the grazing of livestock and obtaining satisfactory use and maintenance of the forage. On western grazing lands salting is of unusual importance, because there livestock graze under open-range conditions, and the problem of obtaining proper use of the forage is complicated by considerations of topography, accessibility, watering facilities, and other factors which affect the distribution of stock.

The wide variation in conditions and the lack of well-defined rules have led to greater diversity in the way range salting is done than

exists in almost any other practice connected with the range livestock industry. It is the object of this circular to bring together the results of experimental work, careful observations, and studies of existing practices, and to outline the principles of adequate range salting of livestock in the West.¹

SALT IN THE RATION OF LIVESTOCK

THE NEED AND EFFECT OF FEEDING SALT

Salt (sodium chloride) is present in nearly all organs and fluids of an animal's body and has been shown by tests to have an intimate bearing on the animal's health.

A French experiment indicated that sheep fed one-half ounce of salt daily "gained materially faster than those fed no salt, and also

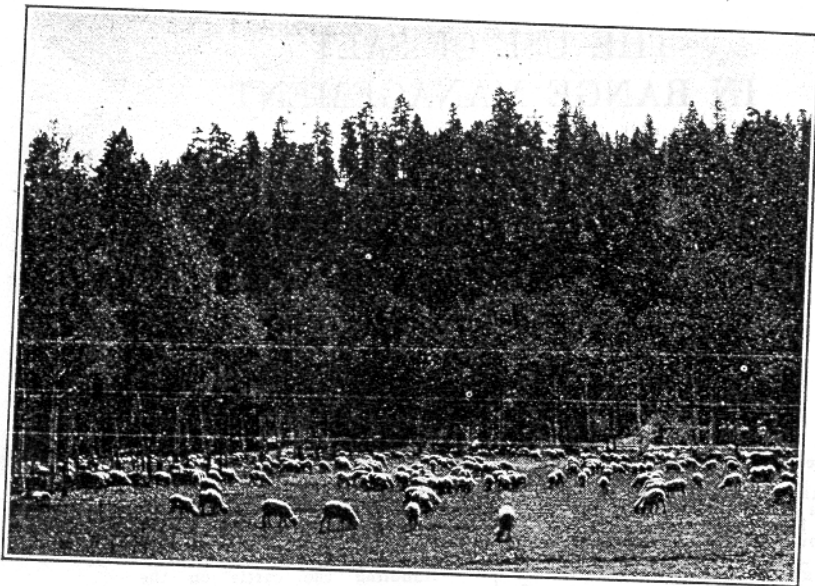

F-150218

Fig. 1.—Proper salting makes more contented flocks, easier to handle under the open herding and bedding out method which means most wool and mutton and least injury to soil, forage, and young timber

somewhat faster than others fed three-fourths ounce daily." The salted sheep also grew heavier and finer fleeces than the unsalted ones. (19.)²

In tests at the Iowa Agricultural Experiment Station, with comparable experimental flocks of ewes fed side by side, two flocks receiving $\frac{1}{4}$ and $\frac{1}{2}$ ounce of salt, respectively, on the average per ewe daily made somewhat better gains and produced better lambs than did the flock which received a per head daily allowance of 1 ounce (4, 5). In similar tests at the same station it was found that "When salt was withheld from the ewes for a period of time, involving the suckling period, they ate earth, gnawed boards, and

kept up a continual din when anyone was around the lots, even though there was plenty of feed and water before them. These ewes actually got so crazy for salt that they would run after one like a dog and bite one's hands * * *. The allowance of salt completely satisfied these ewes, so that they quit all their previous unusual actions and antics * * *" (4).

Results of detailed tests on dairy cows at the Wisconsin Agricultural Experiment Station (2) include the following:

- (1) Chlorine rather than sodium seemed to be the essential element.
- (2) All cows showed a great craving for salt after being deprived of it for two or three weeks, but, as indicated by "general appearance, the live weight, or the yield of milk," the health of the animals did not seem to be affected for a period of from less than a month to more than a year, varying with individual cows.
- (3) "In every case there was finally reached a condition of low vitality in which a sudden and complete breakdown occurred, from which recovery was rapid if salt was supplied. This stage was marked by a loss of appetite, a general haggard appearance, lusterless eyes, a rough coat, and a very rapid decline in both live weight and yield of milk."
- (4) "The breakdown was most likely to occur at calving or immediately after when the system was weakened and the flow of milk large."
- (5) It seemed probable that under conditions prevailing in the tests a dry cow or a steer would suffer no great inconvenience if given no salt except that contained in the normal ration fed. This ration was calculated to contain chlorine equivalent to about three-fourths ounce of salt a day, and it was assumed that this was the minimum amount of salt required per 1,000 pounds live weight, to sustain an animal that was not producing milk.
- (6) The indication was clear that salt in addition to that obtained in food is essential for dairy cows producing milk, the salt requirements of which are necessarily higher than those of dry cows or steers, because about 0.6 ounce of salt is required to compensate for the chlorine contained in each 20 pounds of milk produced. It was recommended that Wisconsin dairy cows be given at least 1 ounce of salt a day, heavy milkers requiring more.

Hensel, at the Kansas Agricultural Experiment Station, found that yearling and 2-year-old cattle on pasture actually licked an average of about 1.77 pounds of salt a head a month from July to October, inclusive (13). In tests at the Iowa station it was found that in feed lots, 2-year-old steers on various Corn Belt fattening rations consumed from 0.27 pound to 2.31 pounds a head a month (6). In a similar test at the same station fattening lambs showed a variation from 0.03 pound to 0.18 pound (6).

Many stockmen have noted a variation in the quantity of salt needed for livestock on different ranges. Important factors influencing this variation are: (1) The salt content of feeds; (2) salt in drinking water; (3) the presence of accessible natural licks; (4) salt loss by weathering; (5) the salt demands of game animals; and (6) possible differences in the requirements of individual animals.

THE SALT CONTENT OF FEEDS

Chemical analyses have shown a wide variation in the salt content of different feeds. There is considerable range in the percentage of ash—the various minerals contained in the plant, including salt—but the amount is consistently less in green samples (12). Analyses of clover, alfalfa, timothy, bluegrass, wheat straw, and corn stover made at the Ohio Agricultural Experiment Station (8) show uniformly lower percentages of both sodium and chlorine in fresh samples than in dry ones. The Texas Agricultural Experiment Sta-

¹ In obtaining information for this publication the writers have had the hearty cooperation of numerous stockmen and forest officers. To all of these to whom individual credit can not be given they wish to acknowledge their indebtedness.

² Numbers in italics in parentheses refer to "Literature cited," p. 32.

tion, conducting similar work with a variety of feeds, found that the salt content of most feeds is low, but that molasses, alfalfa, and packing-house products rank high in this respect (9). The chlorine content of plants which grow on alkali soils varies greatly, being especially high in greasewood (*Sarcobatus vermiculatus*) (10).

Feeding tests indicate that the difference in the quantity of commercial salt consumed by stock may be traced largely to the dissimilarity in the amount contained in the forage eaten. The Iowa station found by feed-lot tests with steers that the quantity of salt licked was several times as much with some rations as with others (6). Changes in ration also affected materially the quantity of salt licked by fattening lambs.

Experience has shown that range cattle require more salt when subsisting largely on the usual browse diet than when on a diet composed of grass and weeds.

Cattle have long been known to crave more salt when grazed on fresh green feed than where the feed is more mature or dry. Jardine and Anderson (15) conclude that stock should have twice as much salt when the feed is green and succulent as when the feed is dry. Hensel (13) at the Kansas station found that cattle licked 2.83 pounds a head in July, 1.88 pounds in August, 1.17 pounds in September, and 1.2 pounds in October, thus taking over twice as much a month during the fore part of the season as during the latter part.

SALT IN DRINKING WATERS AND ALKALI LICKS

Salt occasionally occurs noticeably in the waters of springs, streams, lakes, tanks, and wells. These saline waters sometimes affect the quantity of commercial salt required, but rarely satisfy the full animal requirements. If salt is present in sufficient quantities to satisfy the wants of the animal, the water will more than likely be unfit for general stock-watering purposes.

Natural "salt licks," or spots of soil containing a relatively high percentage of various mineral salts, frequently occur on the range in the West. Salt-hungry animals may lick or eat the dirt at these places, often consuming so much of the saline soil that a decided depression is hollowed out (fig. 2). Stockmen frequently claim that the salt thus acquired is sufficient for the stock on the range, and it is possible that occasional spots contain adequate amounts of sodium chloride; but, if so, they are the exception rather than the rule. It should be remembered also that such alkali spots more often than not contain salts other than sodium chloride, some of which are useless to the animal and may be actually injurious.

According to Hilgard (14) alkali salts in general contain three chief ingredients, namely, common salt (sodium chloride), Glauber's salt (sulphate of soda), and sal soda or carbonate of soda. Epsom salt and bittern (magnesium chloride) also occur in some localities. Very few analyses have been made of the salts in the spots known as licks. Analyses that have been made indicate that a cow dependent entirely on the lick would have to consume several cubic feet of soil each year to obtain the desired amount of sodium chloride. Obviously, the consumption of such a quantity of soil would not be beneficial. On the Lewis and Clark National Forest

of Montana deaths of cattle have been traced to the formation of balls of compact mud in the stomach as a result of eating salty soil.

A recent test on the Lincoln National Forest in New Mexico, on a range where it had persistently been claimed that because of alkali in the soil and water cattle did not care for or require additional salt, showed that the cattle readily licked commercial salt when it was made available for them, even though the alkali was accessible. Another test on the Custer National Forest in eastern Montana showed that on the heavy-alkali portion of the range the cattle were fairly well satisfied with the alkali which was present in drinking water and in licks and with forage high in salt content and paid little attention to the near-by commercial salt. On part of the range, however, the cattle did eat salt. These tests would indicate that the presence of alkali on a range does not necessarily eliminate the need for salting. Alkali is seldom distributed on the range in

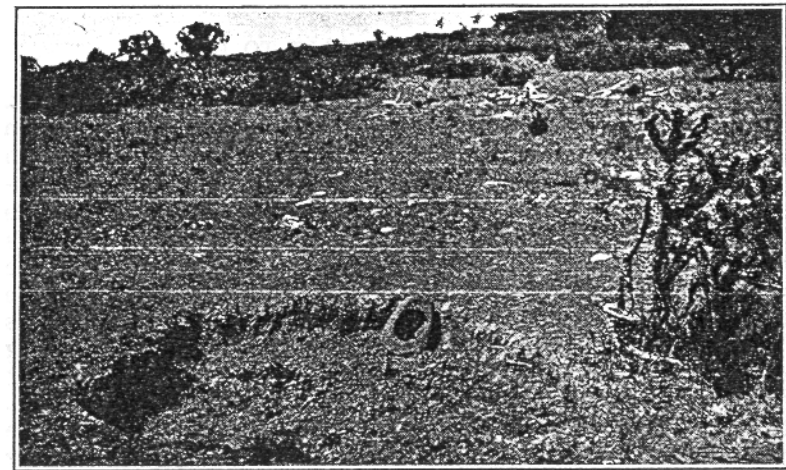

F-172855

FIG. 2.—When cattle are forced to use natural "salt licks" such as this they have to consume a large quantity of injurious soil to obtain the required quantity of salt

a satisfactory way. It may, however, reduce the quantity of commercial salt needed by livestock on those areas where it is available. The simple test of placing salt on the range and allowing the animals themselves to decide appears to furnish the safest guide as to the adequacy of the natural supply of salt, and such a test should be made in each individual case.

PROPER ALLOWANCE OF SALT FOR RANGE LIVESTOCK

In general, a salt allowance of about 2 to 2½ pounds a head a month should be placed on the average range for cattle when feed is succulent or when the cattle are subsisting largely on the usual browse diet. For the remainder of the season 1 to 1½ pounds a month is usually adequate. On the average yearlong range this means a total of about 20 pounds of salt a year for each cow. For sheep grazed yearlong on many southwestern ranges where forage

plants high in salt content are common 3 to 4 pounds a head appears to be an adequate yearly allowance under average conditions. On succulent feed ewes with lambs require a greater average allowance. Where practicable from 50 to 75 pounds of salt every three days for a band of 1,200 ewes and their lambs is more satisfactory than a greater quantity fed less often (15). Fleming (?) observed that best results among several flocks of range sheep in Nevada were obtained with a daily salt allowance of one-half ounce a sheep. On most goat ranges it is probable that 3½ to 4 pounds a head a year will be most satisfactory (3). These allowances provide for a reasonable loss from weathering. Adjustments for alkali licks, saline waters, or forage high in salt content and on the other hand for salt that would be consumed by game must be worked out for individual ranges.

The influence of salt in the handling of stock on the range is so great and the cost of salt relatively so low that it is best to have salt always available.

KINDS AND GRADES OF SALT TO USE

Many forms and market grades of salt are used for livestock. The principal kinds are the "rocks" or "lumps" as they come from the mine, evaporated or crushed grades which come in sacks or in blocks formed under various hydraulic pressures, similar blocks including small percentages of sulphur, coarse granular natural "lake salt," and various medicated brands in granulated form or in blocks or bricks. In any of its common forms salt usually contains some impurities. The mined product may contain thin streaks of shale or other rock, although the best grades are practically free from this objection. It is poor economy to buy rock or mined salt containing considerable shale, clay, or other foreign matter where the freighting and distribution of salt on the range is the item of greatest expense. Where freighting is no item such salt can well be used if otherwise more economical. Small quantities of chemical constituents other than sodium chloride are likely to be present in salt. The percentages of these ingredients in the best commercial grades, however, are very small and their possible injurious effect on stock may be disregarded.

Grazing animals show certain preferences in kinds of salt. They generally favor the softer grades, which permit them to satisfy their needs more quickly. Hensel (13) found that under Kansas conditions cattle chose granulated rock salt first, the evaporated salt blocks next, and other blocks in more or less regular order according to increasing hardness. He states "they apparently desire to allay their hunger for salt as rapidly as possible."

For sheep and goats on the range, granulated or crushed salt is preferred. Such salt can be scattered on the bed ground in small quantities, thus permitting the numerous animals in a herd to satisfy their wants readily. Furthermore, it is generally impracticable to pack a sufficient quantity of block salt properly to supply a large herd.

Relative freedom from impurities, availability, and cost on the range are the main points to consider in making the choice of salt

for cattle. If salt logs or troughs are used, and if distribution can be made frequently, it will ordinarily be best to use granulated salt. Otherwise block salt will be best. With granulated salt in a trough or log several cattle can usually lick at one time, but one aggressive old cow may prevent others from licking at a single block of salt. When coarse granulated or crushed salt is used, however, care must be exercised to see that excessively salt-hungry cattle do not have access to it while it is in a loose, unhardened condition. After crushed salt has been wet it cakes into a solid mass of moderate hardness.

LOSSES BY WEATHERING

Salt exposed to the weather loses in weight, because of the dissolving effect of rain and snow. Though under range conditions a part of the dissolved salt may be licked up from the ground, much of it is a true loss.

The loss is greatest on cattle ranges. Sheep and goats ordinarily are given at one time only enough to satisfy them, but on cattle ranges the cost and inconvenience of distributing salt may restrict salt trips to intervals of about a month. It is essential to place on each ground as much as the cattle will need, and in addition the quantity which is likely to weather before the next distribution.

Hensel (13) found that under Kansas conditions the loss through weathering from July to October, inclusive, averaged about 24 per cent a month for granulated salt and about 10 per cent a month for evaporated blocks and five grades of blocks formed at pressures varying from 400 to 1,000 tons. The difference in loss between the grades of block salt for the four-month period was less than 3 per cent.

A preliminary test at Albuquerque, N. Mex., from July 19, 1922, to March 17, 1923, during which period the total rainfall at that point was approximately 4 inches, showed for coarse sack salt a loss of 36 per cent, for sulphur pressed blocks losses of 7 per cent in a trough and 13 per cent on the ground, and for white pressed blocks losses of 8.7 per cent in a trough and 19.9 per cent on the ground. A subsequent weighing on December 15, 1923, showed that the coarse salt had lost 91.4 per cent, the sulphur blocks had lost 28.8 per cent in the trough and 42.7 per cent on the ground, and the white pressed blocks had lost 29.6 per cent in the trough and 48.2 per cent on the ground.

At Flagstaff, Ariz., a similar test (1) during the same months showed that under the conditions prevailing there, including 15.44 inches of precipitation, there was little advantage from the use of the trough and only small differences in weathering between the rock salt, white pressed block, and sulphur block used in the test. During rainy weather from July 27 to September 24 the average loss for these grades was 11.4 per cent a month. During a dry period of three weeks which followed the loss was negligible, but during the winter rains and snows the monthly loss averaged 12 per cent of the original weight. In the spring dry period again the loss was very small.

Figure 3 shows the actual average loss in pounds from white pressed block and sulphur block samples at Albuquerque and Flag-

staff, with cumulative rainfall for comparison. The ratio between salt loss and rainfall was greater at the station with the heavier precipitation.

A 60-day test (II) at Greer, Ariz. (elevation about 8,500 feet), where the total precipitation during the test was 3.69 inches, showed losses for white pressed block salt of 18.7 per cent on the ground, 10.7 per cent in an open trough, and 3.7 per cent in a roofed trough.

THE ECONOMY OF SALT CONTAINERS

Where crushed or granulated salt is fed on cattle ranges, the use of salt logs, troughs, or boxes is always advisable. Salt is saved and the animals can obtain their salt ration without a mixture of dirt or gravel.

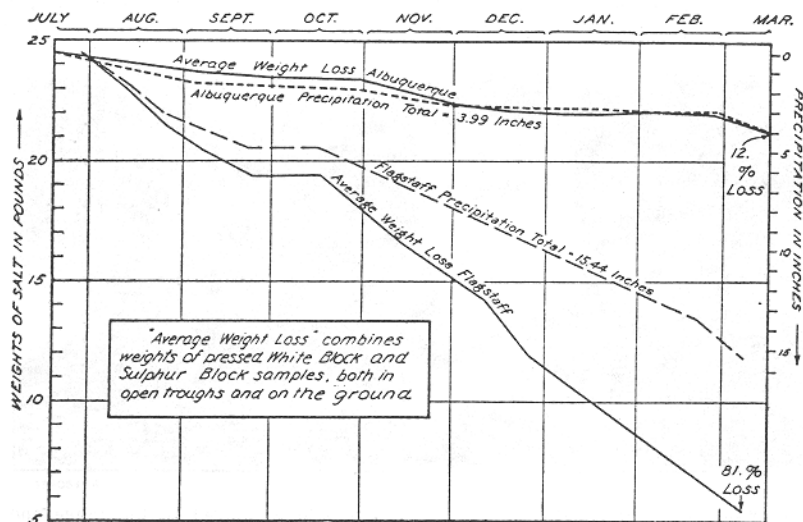

FIG. 3.—Average salt weathering compared with precipitation

Even with block or lump salt, under some conditions, the saving may be sufficient to justify containers. Occasional ranchmen, who place salt on the ground as a general practice, have found it an economy to have one box about 2 feet square at the main salt grounds in which small fragments of blocks may be placed and more completely utilized than if left on the ground. It is seldom necessary or practicable to provide containers for all block or lump salt placed on the range.

Where the attempt is made to provide containers for all the salt used, the cost of containers and the difficulty of moving heavy troughs and logs lead to a tendency toward an insufficient number of salt grounds. Roofed troughs are especially difficult to move, and their general adoption is not advised, although they reduce weathering loss to a small amount.

Small portable troughs or boxes have been used successfully and economically for salting sheep and goats.

CONSTRUCTION OF SALT CONTAINERS

Where logs are readily available to the site selected the log trough is the most economical and most satisfactory type of container (fig. 4). Troughs are made by hewing or burning out the interior of the log (fig. 5). Herders can often make them without appre-

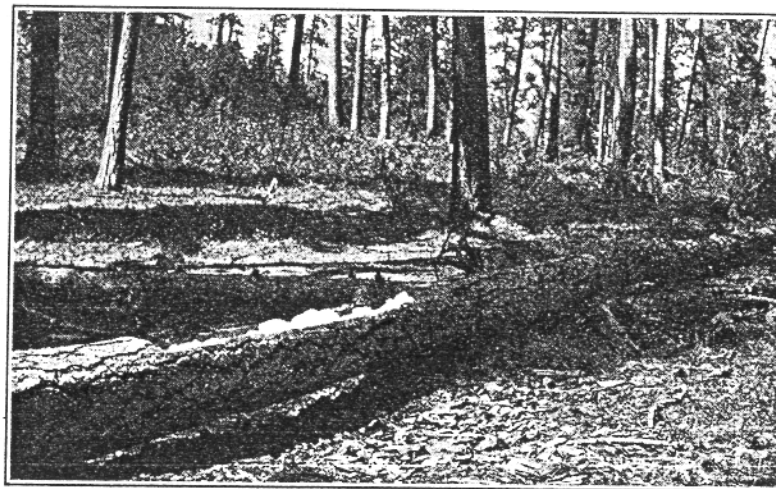

F-160480

FIG. 4.—A salt log on a cattle range. It is always advisable to place loose or granulated salt in containers of some sort—hollowed-out logs, troughs, or boxes

able expense to the stockmen. Figure 5 gives desirable specifications of log troughs which proved serviceable in California (20). Small logs are necessary for sheep and have served well for cattle, although logs as large as 2 feet in diameter are often preferred for cattle. The larger log allows cattle to feed in larger numbers and

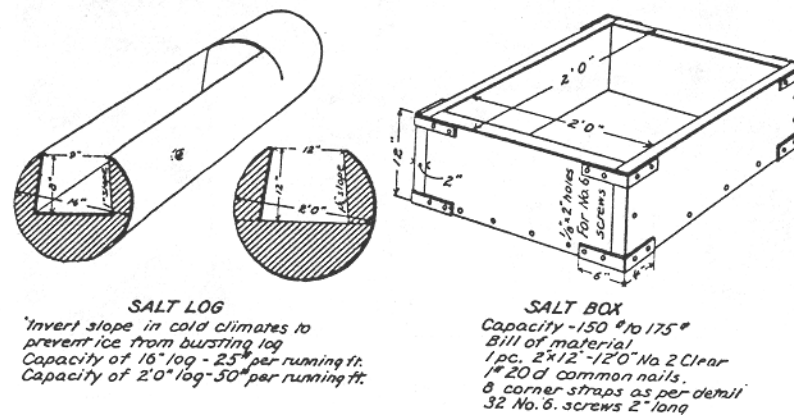
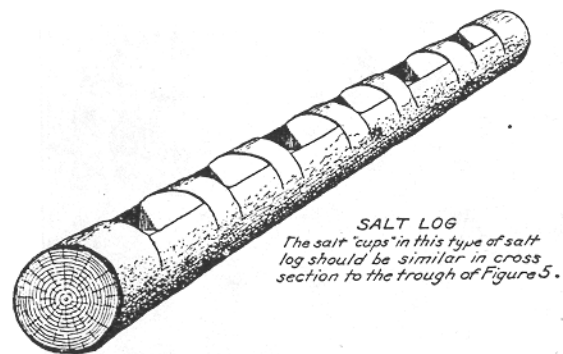

FIG. 5

from both sides at one time with less crowding. Figure 6 shows a salt log with "cups."

Where cheap lumber is available or satisfactory logs scarce, board troughs or boxes are preferred. Two-inch or three-inch lumber is

advised for the construction of troughs or boxes to be used by cattle. Figure 5 also shows specifications and capacity of a salt box. The lumber can be sawed into proper lengths at the time of purchase and hauled or packed to the salting place and the box constructed there. It is important to brace the corners thoroughly, as indicated



SALT LOG
The salt 'cups' in this type of salt log should be similar in cross section to the trough of Figure 5.

FIG. 6

the bottom to insure drainage of rain water. Since animals tend to gnaw salt containers, it is a good plan to protect exposed edges by stapling smooth wire along them.

Portable troughs about 4 feet long for salting sheep and goats may be made of light lumber, canvas, or sheet iron, and con-



F-40778-A

FIG. 7.—Before the range about a salt ground becomes overgrazed the use of that ground should be discontinued, and the trough be moved if feasible

structed so that they will fit compactly together or fold into a small space for packing. One-inch lumber has proved satisfactory for this purpose. Canvas troughs require light frames to give stability (7).

in the illustration. These boxes and light troughs can readily be moved to prevent excessive trampling in any location (fig. 7). Troughs are ordinarily made 9 to 14 inches wide, 6 to 12 inches deep, and 10 to 12 feet long.

Containers should not be water-tight, but should have enough cracks or holes bored through

SALT STORAGE

Salt must be out on a new range as soon as livestock are moved to it if any appreciable effect is to be expected in locating them in their new surroundings. In the early spring and during the summer rainy season roads are apt to become impassable. Salt should therefore be hauled to the range at some other season and stored at a point from which it can conveniently be taken to the salting places. The headquarters ranch or herder's cabin will ordinarily serve as the central storage. Additional storage places at other convenient locations on the range, preferably accessible by wagon road, are advisable on large ranges. It seldom pays to construct cabins for salt storage only; a covered box which affords protection from the weather is sufficient (fig. 8). A covering of wire netting affords some protection from gnawing animals and is recommended by Peterson (16) and others. Storage boxes 8 feet long, 3 feet deep,

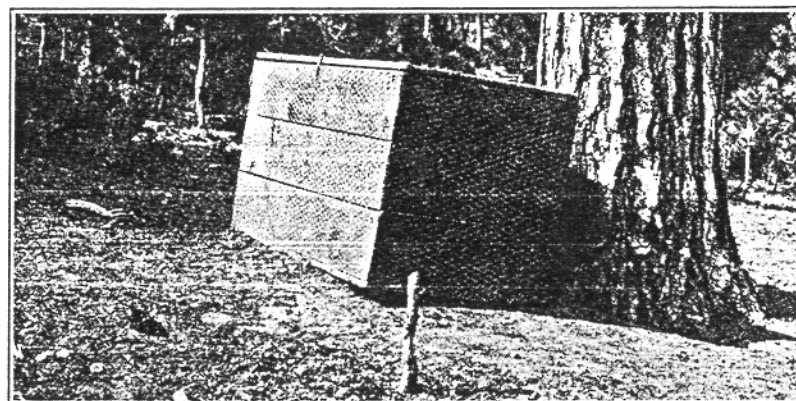

F-180481

FIG. 8.—A substantial salt-storage box. Salt should be hauled to the range and stored in camp cabins or covered boxes, where it will be convenient for distribution to the salting places

and 3 feet wide have proved satisfactory, though they may be made in any desired size.

SALTING ON CATTLE AND HORSE RANGES

In the past owners too often turned their cattle loose on the most convenient range and allowed them to drift and locate almost at will. Under such conditions cattle congregate on the more accessible areas and those of most palatable forage. Furthermore, they tend to drift to the higher elevations too early, to the detriment of their condition and of the range forage. Considerable improvement has been made upon such methods, but much remains to be done on most ranges to maintain or increase the forage production and to bring about more satisfactory and more economical production of cattle. Salting plans, though they alone can not correct all the natural faults of distribution or of other phases of management, offer the greatest possibilities for bringing about immediate

improvement in management on cattle ranges. Salting plans should be coordinated with all phases of cattle management on the range (15).

Cattle will go to salt much as they will go to water. Careful location of salt in the right quantities and in accordance with a definite time schedule can therefore be used to lessen congregation of stock and overgrazing on certain favored areas such as meadows, bottoms, natural passes, and areas about water, to increase the use of portions of range normally lightly used, and to aid in controlling cattle locally so that the forage will be utilized to best advantage.

On national-forest ranges definite plans for salting in accordance with other phases of range management have been formulated and put into practice with markedly beneficial results. It is seldom possible to prepare an ideal salting plan at the first attempt; but a brief and concise written plan, with an illustrative map, based on the best information available, forms a basis for further study and improvement. In making a salt plan for any grazing area, careful consideration must be given salt allowance per animal for the season; grazing capacity of the area and of each of its component parts; proper seasonal use of forage; advisable number and location of salt grounds; livestock habits; facilities for storage and distribution; and cost estimates of purchase, haulage, distribution, and additional improvements.

SALTING TO OBTAIN LOCAL DISTRIBUTION OF CATTLE

In devising a plan for distribution of the cattle allotted to a given range, the whole area should be divided into the natural management units, such as small watersheds, and the carrying capacity of each determined. These management units may then be further divided into the areas which can be used conveniently from the different salting places.

Where the range is comparatively level or but slightly rolling, watering facilities abundant, and the type of forage uniform, such division is a simple matter, and salt may be evenly distributed over the area as best meets the needs of the livestock and the range. Where topography is rough, watering facilities limited, and feed patchy or of widely varying value, the division is more complicated and salting and herding are more important.

Under the latter conditions the practice should be to place salt where the feed is available, adjusting the amount of salt to the quantity of usable feed accessible from each salting place. Since cattle tend to congregate about water, on choice feed, and on the areas most easily reached, it is best to salt sparingly if at all in such places but somewhat heavier in timbered areas in which danger of injury to young trees from grazing is negligible, in areas with a plant cover of relatively low forage value, and on usable slopes. In order to accustom cattle to grazing the less desirable portions of the range and to finding the salt located there, it is often found necessary to distribute some of the cattle with the salt and later to drive some of them again to the new salt grounds. Several drives may be required.

There is no object in placing salt on slopes too steep or too rocky for cattle to graze over, and the vegetation on such slopes should

not be considered in allotting cattle to a range unit. The usable forage on the remaining portions is the basis for deciding on proper numbers and salting to obtain full use. If vegetation on inaccessible areas is included in carrying capacity estimates, the usable range will be overgrazed, which will mean range damage, erosion, and unsatisfactory livestock production.

Studies (18) of grazing in the Southwest have shown that for satisfactory management cattle may be expected to graze out 2 or 2½ miles from water on level or undulating ranges, about 1½ miles on rolling, and one-half to 1 mile on rough range. If temporary water is available during part of the year beyond these distances, a partial use of the outlying forage may be considered in determining the carrying capacity of the range, provided the livestock can be promptly moved to adequate range when the temporary water fails. The distribution of salt for cattle should be kept within the limits of walking distance from water. Timely salting near or beyond the limit from usual waters, however, may be used to encourage cattle to graze beyond during those periods when rain,

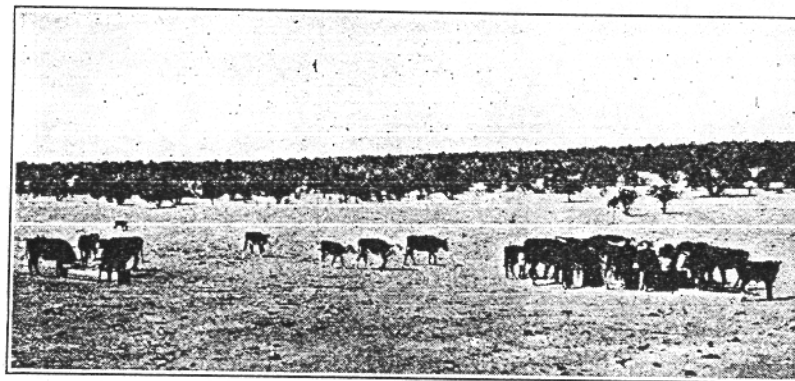

F-172788

FIG. 9.—Salting cattle only at or near water causes unnecessary congestion and overgrazing about the water

snow, fog, or dew is sufficient to satisfy their water requirements. If salt is located only at or near the regular watering places (fig. 9), much of the outlying feed will be wasted; furthermore, if the unsalted outlying feed has been included in determining the number of stock to be allotted to the whole area, the more accessible parts of the range will be overgrazed, and a cut in the number grazed will be necessary.

Salting plans should definitely provide for the placing of an adequate quantity of salt in the outlying areas when temporary water is available (fig. 10) and for the moving of as many cattle to these salt grounds as the feed and water will support. It may not be possible to specify exact dates between which these outlying grounds are to be used, but the approximate length of period can be determined in advance. Although it is ordinarily best and often necessary to drive them, cattle will sometimes follow local showers and will usually find salt placed in easily reached places. If the temporary water and feed are adequate to take care of an appreciable number for a month or more, the best practice will be to

remove salt from about the regular waters. When other salt was not available cattle have been observed to return to the vicinity of permanent water for salt alone.

On yearlong ranges of the Southwest where permanent water is scarce or its development expensive but where temporary water is ordinarily abundant during the summer rainy season, definite plans for protection of the range about the permanent waters during the growing season is extremely important. During this period cattle often do not come in for water more than twice a week, and in winter when snow is available on the range they may remain away for longer periods. Salting only the outlying range at such times encourages more even utilization of all the feed and saves more of the feed near permanent water for critical periods of the year.

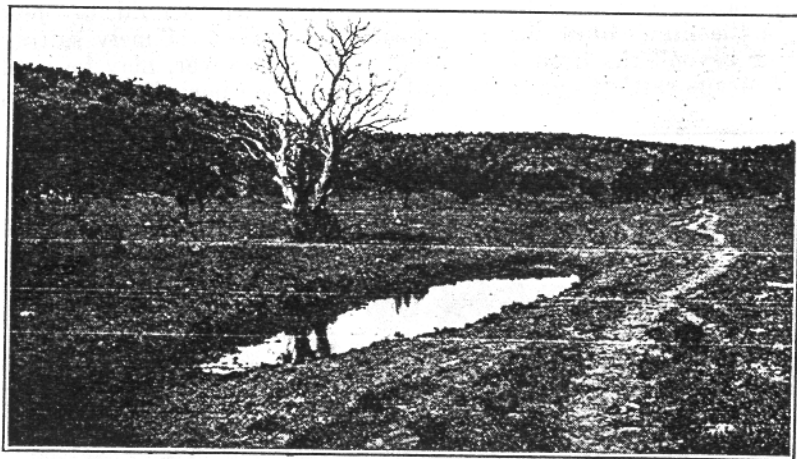

F-172860

FIG. 10.—Good feed about temporary water hole. On ranges where permanent water is not plentiful, it is good practice to remove salt during wet weather from areas grazed from the permanent waters and to salt the portions which can be reached from temporary supplies

SALTING TO OBTAIN SEASONAL DISTRIBUTION OF CATTLE

It is not always possible to get the best utilization by an even distribution of cattle over the entire range. Management plans in many cases call for deferred grazing about permanent waters or on those areas of most value for fall, winter, or spring, for a system of deferred and rotation grazing on the range as a whole, for timely use of forage palatable only during the growing season, or for a zonal distribution on mountainous range in accordance with the vegetative readiness of the forage. In such cases timely salting of the different parts of the range is important in controlling the stock. To further such management properly located interior fences, in addition to the usual boundary and main-division fences, may in some instances be feasible. Ordinarily, however, their cost is not warranted for the purpose of providing better control of small range units of low value, except as short fences may be used in strategic places to close the more accessible passageways. Topographic features may aid materially in control and full advantage should be taken of them. The development of additional watering

places may also be needed. Salting and herding, however, furnish the most practicable means for this local control.

Grama grasses (*Bouteloua* spp.) are excellent fall and winter forage in the Southwest. On the same ranges with these grasses may be found others, such as Arizona fescue (*Festuca arizonica*) and mountain bunch grass (*Muhlenbergia montana*), both of which are more palatable to livestock during the summer growing season than at any other time except for a short period following maturity, when the ripened seeds are relished. Tobosa grass (*Hilaria mutica*), galleta grass (*H. jamesii*), three-awn grasses (*Aristida* spp.) and others of most value during the summer growing season occur in the Southwest in large range types interspersed with grama and other types that furnish good feed in fall and winter. Plans should provide that during the growing period salt should be placed on the summer-range types. If the range which can be satisfactorily used from these salting places is sufficient to provide for the cattle during the summer, no salt whatever should be placed at that time on areas of good fall or winter feed.

Similarly the pine grasses (*Calamagrostis* spp.) cover large range areas of the Northwest and furnish good feed during the growing period, but become coarse and wiry at the time when other feed areas are of most value and have seeded or are approaching seed maturity. Accordingly, if the pine-grass areas alone are salted from May 15 or June 1 to July 30 or August 15 and cattle are distributed so as to make best use of this feed and salt at that time, satisfactory use of the pine grass will result. Furthermore, the other range areas will be grazed lightly or not at all during their growing season, and by later moving the salt into those areas deferred, full use of the entire range will be obtained.

Deferred and rotation grazing of cattle ranges requires careful division of the range into several management units each of which in turn can be protected until after seed maturity for one or more years. By withholding salt from the deferred area until time for its use and by locating salting places in other parts of the range so as to discourage straying into the deferred area, a partial control can be obtained. Stray animals can be removed periodically and placed on salt in other parts so as to discourage further straying.

On many extensive areas of the West annual plants grow in abundance for short periods. The alfalaria (*Erodium cicutarium*) and Indian wheats (*Plantago* spp.) of the Southwest, and the downy brome (*Bromus tectorum*), wild oats (*Avena fatua*), and bur clover (*Medicago* spp.) on the ranges of California furnish abundant winter and spring feed in favorable seasons. Such annuals as downy brome furnish considerable forage in the spring on other western ranges. If these plants are not used when green and succulent their value is largely lost, since they mature quickly and then shrivel up. Salting plans, therefore, should provide for salting these areas while the crop of annuals lasts.

In mountainous areas (fig. 11) the vegetation develops later with increase in elevation. In central Utah the average delay is about 14 days for each 1,000 feet (17). A similar delay of from 10 to 14 days in Washington and Oregon is recognized in the making of detailed salt plans (16). The main forage plants should have

made a vigorous growth before livestock are turned on the spring or summer range. Ordinarily most of the bunchgrasses should be about 6 inches high and 25 per cent or more of the heads of the earlier maturing perennial grasses should be showing. Such a stage of development will usually be reached in about three or four weeks of growth. Repeated removal of herbage year after year before the forage plants have reached such development lowers their vitality, reduces the volume of forage produced, and delays or prevents the production of fertile seed. As a result inferior plants gradually crowd out the better forage plants, and the quality of the range is seriously lowered. A zonal use of the range in accordance with the development of the important forage plants in each altitudinal zone is therefore essential. The variation in development of forage on the different exposures at the same elevation should also be taken into consideration.

A quantity of salt in accordance with the carrying capacity of each zone and exposure should be placed in each only during the season when that specific area should be grazed. Thus, as the forage developed at the higher altitudes the salt would be placed in the next zone

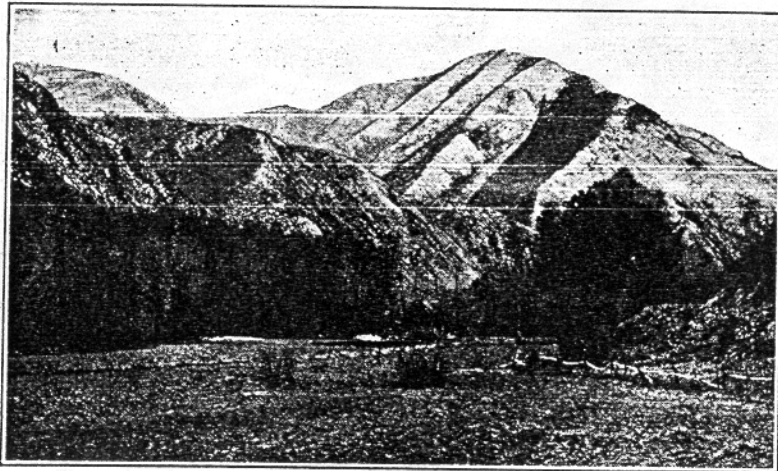

F-161978

FIG. 11.—Rough type of country in Utah satisfactorily used by cattle in the spring and early fall largely by means of adequate salting. Salt was placed only on the slopes, benches, and ridges

above, and any that might remain would be removed from that below. In the fall after the forage at the higher elevations had been properly grazed the salt would again be placed in the lower zones to encourage use of the feed which had grown during the summer, and any surplus salt would be removed from the upper zones. If salt is not removed from each zone when it has been fully utilized, some cattle will remain near this salt and overgraze the range. Large blocks which last through the winter will attract cattle to the upper zones in the spring before the forage is ready to be grazed.

LOCATION OF SALT GROUNDS

Salting places must of course be so located that they will best aid in the desired range management. The kind and character of feed, cattle habits, topography, watering facilities, danger of erosion, danger of loss from poisonous plants, and danger of injury to valu-

able timber reproduction are always important factors to consider. Salt-ground sites should be selected with a view of drawing cattle away from spots or localities already overgrazed or too heavily used or those most likely to become so (fig. 12). It is of course



F-41868-A

FIG. 12.—Salt on valley bottoms and other areas where cattle naturally congregate increases overgrazing and uneven use of the forage on the range as a whole

essential to have the salt in a place readily reached by cattle where they can easily get their fill without danger of injury. A flat shady place is preferable. Accessible ridges, knolls, and benches (fig. 13), the more level places on slopes, and small openings in browse and timber (fig. 14) types are the main desirable locations. Lightly

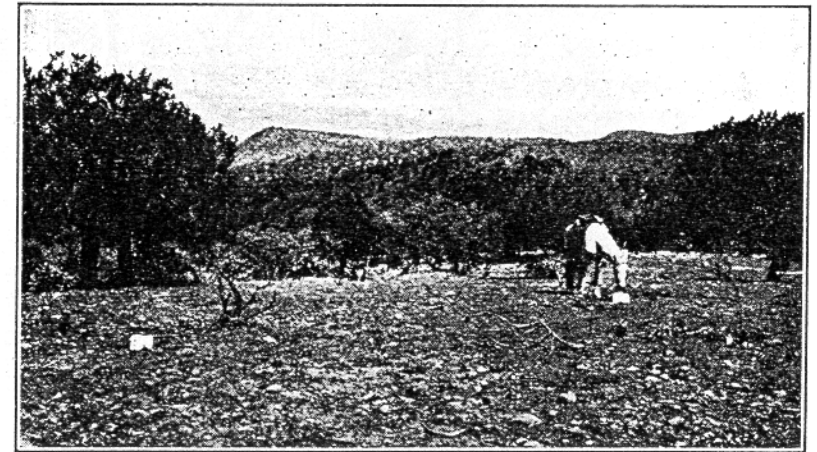

F-171439

FIG. 13.—A well-located salt ground about one-fourth mile from water on a flat bench where erosion danger is negligible

used areas in timber, patches of vegetation of low palatability, and accessible corners of the range where cattle seldom graze should be favored over areas normally fully utilized. Occasionally a smooth rock outcrop barren of vegetation can be used to advan-

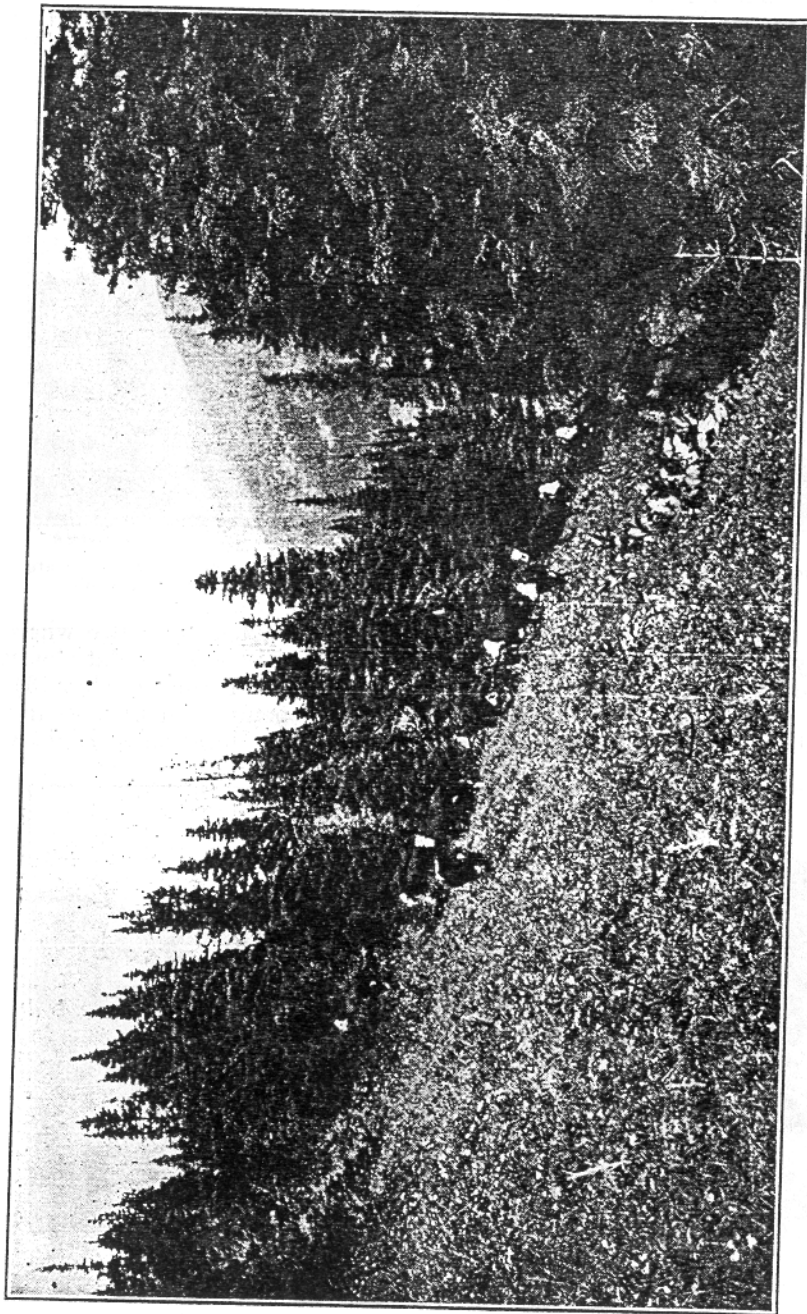
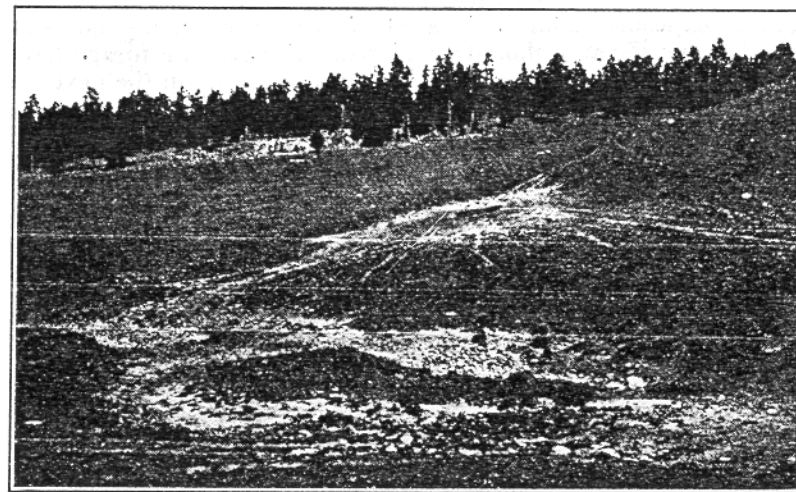

FIG. 14.—Salt placed in small openings in timber on slopes promotes more even utilization of all the forage

F-160147

tage. The aim should be to obtain uniform use of the feed between salt and water over the entire range. A shift in location of salt grounds should always be made before decided damage occurs to the range (fig. 15).

To obtain best results in control, distribution, and condition of cattle, and in utilization of forage, salt should not ordinarily be placed along natural stock passways near unfenced boundaries of management units, or on overgrazed, eroded, or dangerously used areas (fig. 16), such as valley bottoms, borders of springs, and other watering places, roads and main trails, "saddles" in ridges, and meadows, open parks in timber and similar areas of choice feed. Then, too, it is advisable to avoid places difficult for animals to reach, including dense timber, dense brush, and excessively steep or rocky slopes; also danger areas such as patches of larkspur or other poisonous plants, boulder-strewn spots, low ground apt to get "boggy," and



F-172781

FIG. 15.—Deep-worn trails, completely trampled-out circles of sod, and increased erosion result from salting too many cattle on the same spot for years

rims or "break offs" of canyons where stock trails begin. To prevent undue interference with other forest uses, salt grounds should not be located in clumps of young timber growth or near recreation centers.

It may require some time to train cattle to get proper use of salt after taking it away from stream bottoms where they have been accustomed to find it. Satisfactory results are not ordinarily obtained the first year.

It is sometimes desirable to salt temporarily at a new flood-water storage tank until the basin becomes thoroughly trampled to improve water tightness. It may be advisable to salt for a few days or a week at a temporary watering place when salt and cattle have been moved from near permanent water. In drought emergencies, when cattle are poor and weak, it may be advisable to leave some salt near the water such animals are using. In adopting better distribution of salt on some ranges where it previously has been placed only at

water, it may be expedient to leave some salt at water the first year until cattle become accustomed to salt in other parts of the range. With these exceptions salt should be placed at a reasonable distance from water. On many cattle ranges it was common practice for years to salt only at water in the belief that hardship or even losses among the animals would result from moving the salt away. Actual counts under various conditions where salt and water were together have shown that, although cattle may alternate between salt and water before leaving a watering place for outlying feeding grounds, they often lick salt last rather than drink last. During rainy weather some even came in to the combination salt and watering place for salt only. The risk to the animals from salting away from water is negligible, provided the animals are plentifully supplied with salt throughout the grazing season.

The distance at which salt should be placed from water depends largely on the water distribution and abundance, the lay of the land,



F-1 W. R. C.

FIG. 16.—A very poor location for a salt ground. Salt placed in an overgrazed and eroded park, and especially along a road, attracts still more animals to an area already damaged

character of the feed, condition of the range, and condition of the cattle. No set rule can be given. Distance itself is only a guide. Ordinarily salt should not be less than one-fourth of a mile from water, though where travel is difficult or waters numerous the nearest salting places may be as close of one-eighth of a mile. In working out a salting plan on each individual unit, the aim should be to correct avoidable congestion of animals and to obtain even use of feed rather than to locate salt at any given distance from water. The conservative travel limit of the animals should, of course, never be exceeded.

NUMBER OF SALTING PLACES

The most practicable number of salt grounds must be determined separately for each individual range. It is just as important to prevent excessive trampling of cattle about a salt ground as it is

about water or in other natural congregating places. Accordingly, enough salting places must be available to insure, as far as practicable, the desired utilization and management and to prevent depletion about the salting place. From this point of view many grazing units are still insufficiently supplied. Where the range is level or undulating and in yearlong use, and the feed is made up of large uniform types of relatively low value, salt grounds may be placed as far apart as 2 miles with entire satisfaction. Ordinarily, however, better results will be obtained where salt grounds are not more than 1 mile apart or where there is one for each 600 acres or so—the equivalent, on short-season ranges, of one for each 40 to 60 head of cattle. Where the topography is rough and the salt grounds are used for periods of a month or less, there may be one for every 20 head the full summer season. It will be found best to have an abundance of salting places rather than too few.

SALT ALLOWANCE FOR EACH GROUND

The quantity of salt allotted to each salting place should be based on the grazing capacity of the area to be grazed from that place during the desired period of use. The salting requirements of the cattle and the amount of weathering are important considerations. If, for example, on an area of grass range 60 pounds of salt a month is required for 30 head of cattle during the early part of the grazing season, about 30 pounds a month will ordinarily be adequate during the latter part of the season. If too small a quantity of salt is put out it will become exhausted, the cattle will tend to drift, and the forage to be grazed from the salt ground will not be fully used. If an excessive amount is put out, an unnecessary loss through weathering will result and too many cattle will be attracted to the salt ground, provided the total for the whole range is approximately correct. Consequently, effort spent in making a careful estimate of the allowance for each ground will be well repaid.

MARKING SALTING PLACES

On the national-forest grazing areas signs (fig. 17) should be provided to denote the important salt grounds which form the framework of the salting scheme. Such signs indicate the specific location for salt, tie to the ground the provisions of written salting plans, aid new men in distributing salt, and furnish a basis for clear discussion of all salting problems between forest officers and stockmen. The cost and time required to place signs at all of the grounds is not ordinarily justified, although this may be necessary on occasional ranges in order to get satisfactory salting without unwarranted supervision. If the location of 1 out of every 5 to 10 is marked with a sign, the remainder may be satisfactorily located by known landmarks. Each salting place should be numbered or named. Many stockmen prefer that the signs bear names rather than numbers. Local conditions should determine which kind is to be used. On rough ranges signs ordinarily specify the location of salt. On level ranges where the same salting place is used each year for several months at a time, sod damage can be kept at a mini-

mum by occasional shifting of the exact location of the salt. On open level ranges a leeway as great as 100 yards from the sign may be allowed. Where several blocks of salt are used on one ground they should be spaced several yards apart to permit more cattle to lick at one time (fig. 18).

DISTRIBUTING THE SALT TO THE RANGE

Salt is ordinarily hauled by wagon or truck to the storage places, which are so located as to aid the rider in further distribution of the salt over the range. Since salting places should not ordinarily



F-165633

Fig. 17.—A salt-ground sign. Signs to mark the location of salt grounds simplify the use of written salting plans, aid new men in distributing salt, and in other ways encourage systematic salting.

ing a salting plan the habits of the cattle should be taken into account, but should not be considered as fixed.

When cattle are to be located on a new range, it is important that salt be placed on the salt grounds at the time or preferably before the cattle are brought on the area. Care at this time in separating the cattle into small bunches and distributing them to the salt grounds somewhat in accordance with the number to graze at each will help materially in getting them settled. In moving bunches to salt grounds it is well to take them past the water which they will use. Likewise, when some drift from the area salted, they should be brought back past the water and placed again on salt. Old cows which continually stray from the range should be disposed of, since

be along roads, the pack horse or two-wheel cart is by far the best method of transporting salt on average mountain ranges. If a wagon or truck is used, the convenience of the driver rather than the needs of the range is likely to control distribution. Salt for grounds requiring up to 50 pounds is sometimes carried across the saddle and taken to the ground when the cattle are driven to it.

HANDLING THE CATTLE ON THE RANGE

Cattle tend to form grazing habits and may locate on one particular part of the range as long as feed is available or until storms drive them out. In devis-

they will often lead young stock with them and cause an excessive amount of straying and riding.

On areas where cattle have become more or less wild, usually in rough country on timbered or brush ranges, cattle can sometimes be more easily driven to a new salting place if one or more gentle cows are included with the bunch. Several attempts may be required, but eventually some of the animals which have been shown the salt ground lead others to it and its use becomes established. Salting in corrals on such ranges has also tended to make the handling of the cattle easier, especially during round-ups.

In the belief that the gathering of cattle will be made easier, the practice has also been followed on some such ranges of withholding salt from all grounds for two or three weeks before a regular round-up. Four or five days before the round-up begins, salting is usually

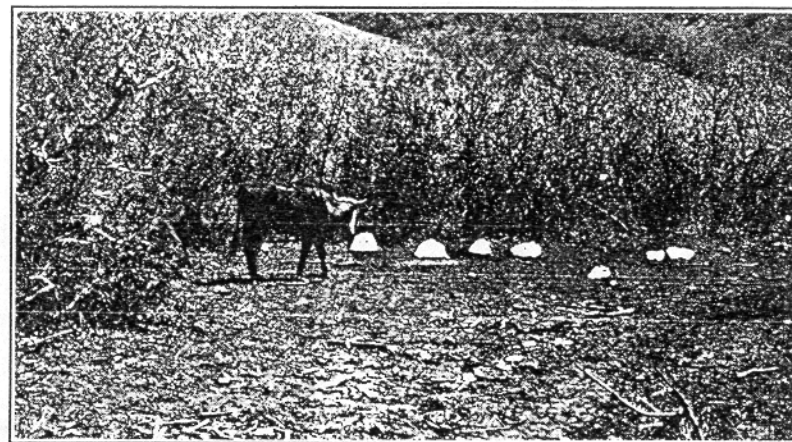

F-2 W. R. C.

Fig. 18.—Three salt-ground mistakes. Too much salt at one place results in unnecessary weathering. Insufficient spacing of lumps permits a "boss of the herd" to keep weaker animals away from the salt. Both range and animals suffer when salt is placed on high ranges too early in the spring.

resumed on a few carefully chosen grounds, to draw the cattle to areas where they can conveniently be gathered.

On some rough timbered or brush ranges, instead of keeping salt available at all times, it has been the practice for the rider to take salt with him, to cover the range systematically at frequent intervals, and to call the cattle at convenient salting places. They become accustomed to the call and those within hearing come in for salt. This enables him to check their number, distribution, and condition, and aids in the gathering of the animals at round-up time, although it adds somewhat to the expense.

DUTIES OF THE RIDER

On most mountain ranges a rider can care for from 800 to 1,500 cattle, except during round-up periods and emergencies. His main duties are to distribute salt and so handle the cattle that they will

be contented and remain settled in the areas to which they are taken, to give the cattle such attention as their condition requires, and to keep the bulls distributed evenly among the cows. Although these duties ordinarily require the bulk of the rider's time, spare time can well be used for constructing and repairing drift fences, trails, and watering places, and for the eradication of larkspur, water hemlock, or other poisonous plants which may cause losses.

SALTING PLANS FOR NATIONAL FOREST RANGES

The development of satisfactory salting plans on national-forest cattle ranges is recognized as a problem of major importance. Stockmen who use the range should cooperate in formulating the salting plan and in selecting the specific sites for salting. The fullest benefit can not be expected unless advantage is taken of the practical knowledge at hand concerning the particular range and animals. The essential points can be mutually agreed upon on the range. Opposition and differences of opinion often arise that must be worked out through experience. Changes found necessary in the plan from year to year should therefore be considered on the ground with the interested stockmen.

Once the provisions of the salting plan are specified in writing, the responsibility of each individual concerned is definitely fixed. The result is that less supervision is required from forest officers and stock owners. Likewise the salting practices are more stable, even though changes may occur in the ownership of the livestock or in the personnel of the range riders.

FORM OF THE PLAN

Salting plans should be simple, concise, and definite, and applicable to each cattle and horse division or allotment. As much of the plan as possible should be shown on the map, which is the most essential part of the plan. The map (see fig. 19), usually on the scale of 1 inch to the mile, should clearly show for each small management or control unit the boundaries of the unit, the number of stock which should graze on it, and the dates for grazing. The movements of stock, to effect general and seasonal distribution over the entire division, may also be indicated. The location of each salt ground, both those to be used and those abandoned, should be shown; also the number of pounds of salt to be placed at each ground. Salt-storage places, fences, watering places, trails, and other features that may influence the salting should also be shown.

The written part of the plan should specify briefly the duties of each party to the plan, particularly of riders and those who will deliver the salt to the storage places, and where the cattle will be delivered to the riders when they come on the range. A tabulated salting schedule showing the dates for salting each ground and the quantities to be placed at each ground supplements the map, and may be placed on the same sheet if space permits. Table 1 gives the salting schedule for the cattle range shown in Figure 19.

TABLE 1.—Salting schedule

Ground No.	Oct. 1	Nov. 1	Dec. 1	Jan. 1	Feb. 1	Mar. 1	Apr. 1	May 1	June 1	July 1	July 15	Aug. 10	Sept. 1	Total
	Lbs.	Lbs.	Lbs.	Lbs.	Lbs.	Lbs.	Lbs.	Lbs.	Lbs.	Lbs.	Lbs.	Lbs.	Lbs.	Lbs.
1.....	100	100	50	50	50	50	150							550
2.....	100	100	100	50	50	100	100							600
3.....	100	100	50			50	100							400
4.....	100	100	50			50	150							450
5.....	100	100	50			100	100							450
6.....	100	100	50	50	50	100	100							500
7.....	100	100	100	50	50	100	150							650
8.....	100	100	100	50	50	50	150							600
9.....	50	50	100	100	100	50	50							500
10.....	50	50	100	100	100	50	50							500
11.....				100	100	50								250
12.....				100	100	50								250
13.....			50	100	100	50								300
14.....			50	50	50	50								200
15.....			50	100	100	50								300
	900	900	900	900	900	900	1,100							6,500
16.....								200	200	100				500
17.....								150	100	100				350
18.....								150	100	50				300
19.....								150	100	50				300
20.....								200	200	100				500
21.....								200	150	50				400
22.....								150	150	50				350
23.....								200	150	100				450
24.....								200	150	100				450
25.....								200	150	50				400
26.....								200	150	50				400
27.....								150	100	50				300
28.....								150	100	50				300
								2,300	1,800	900				5,000
29.....										100	100	50		250
30.....										100	100	50		250
31.....										100	100	100		300
32.....										100	100	50		250
33.....										100	100	100		300
34.....										100	100	100		300
35.....										100	50	50		200
36.....										100	100	50		250
37.....										100	50	50		200
38.....										100	50	50		200
39.....										100	50	50		200
40.....										50	50	50		150
41.....										100	100	50		250
42.....										100	100	50		250
43.....										50	50	50		150
44.....										100	100	50		250
45.....										100	100	50		250
46.....										100	100	50		250
											1,700	1,500	1,050	4,250

The distribution and salting of cattle on the range shown in Figure 19 provide for reserving the grama grass area for fall and winter use and for full utilization of the coarse bunch grasses in late spring and early summer when such use is possible. Salting is delayed on the rough high range so that the forage there is nearing seed maturity by the time grazing is started. The outlying, poorly watered feed on the low winter range is utilized when snow and winter rain are available. At such times salt is placed at temporary grounds convenient for the cattle and is decreased or eliminated on areas near permanent water in order to reserve as much as possible of the feed convenient to that water for use in late spring when feed over the zone as a whole is becoming short.

APPLICATION OF THE PLAN

The plan of control on the range shown in Figure 19 is not ideal. What can actually be done on the range must always be considered. Furthermore, no plan can be absolutely rigid or final. The quantities allotted to each ground and the dates given for salting and

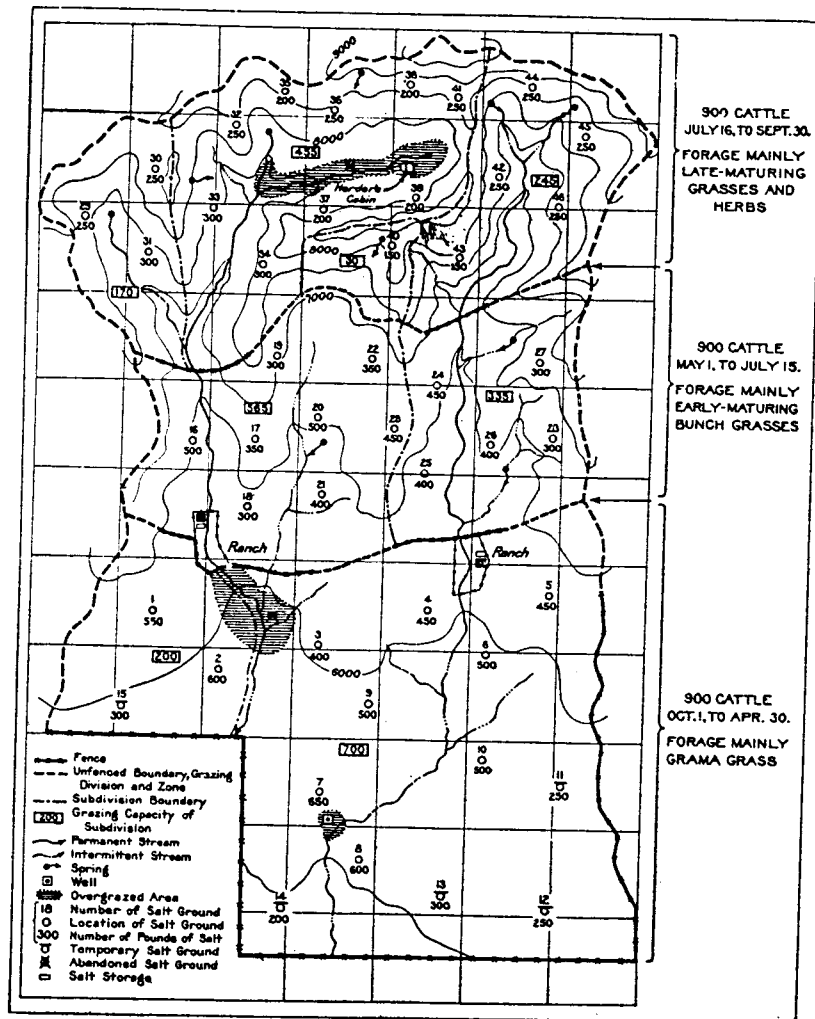

FIG. 19.—Salt-plan map for a typical southwestern cattle division

moving of cattle are relative. In actual practice the entire number of cattle can not be moved and located at the grounds on any one day. Likewise, some drift between zones can not be economically prevented. Moreover, near the close of the season, when the feed supply is rapidly waning, some cattle naturally drift to the next zone and thus facilitate moving. It is also usually found desirable

to place some salt on grounds in addition to those shown on the map in order to encourage more satisfactory use of areas lightly used, particularly late in each season. Likewise, it is necessary to reduce the allotted quantities on those grounds around which the forage becomes fully utilized before the end of the season. Thus each year desirable adjustments are worked out through actual practice on the range.

A higher cost may result from additional riding, greater numbers or better distribution of bulls, and other features. This higher cost incident to the wide distribution of salt on the range as compared with the use of a few salting places is usually offset by the added returns from increased use of forage, better condition of animals, and the reduced damage to range, forest, and watershed.

RESPONSIBILITY FOR CARRYING OUT PLAN

If an individual owns all the cattle grazing on a division, he is responsible for the application of the salt plan. On most ranges of the national forests, however, a number of owners graze their cattle on each range allotment or division. Under such conditions a cooperative plan of salting is essential. Occasionally each permittee accepts the responsibility for some phase of the salting, either the hauling and storage of the salt or the distribution of salt to certain grounds and the handling of the cattle about those grounds. Although this system reduces the cash outlay and has worked satisfactorily on some ranges, ordinarily it results in a few of the permittees doing the bulk of the salting.

The best practice on community ranges is to form an association of all the stock owners using the range, which is made responsible for the execution of the salting plan as well as for the application of other phases of range management (15, 16). The association hires a rider or riders, depending upon the size of the range, to do the salting, handle the cattle on the range, care for the range improvements, and do such other things as time permits. Officers are elected, and an advisory board is formed which acts as an executive committee and represents the association in its dealings with the Forest Service. This board also handles the purchase, hauling, and storage of salt. The officers and advisory board ordinarily act without compensation. All expense is prorated against the number of stock grazed and each owner pays the per head charge for the entire number which he is permitted to graze on the allotment. The biggest point making for success is the agreement among the owners, which results in a fair division of the expense and has gone far to relieve the suspicion once prevalent among cattlemen that they were salting their neighbors' cattle. In developing salting plans on an allotment, it is not always possible to satisfy every individual stockman, but if the majority are in agreement with improved practices considerable betterment can be accomplished.

SALTING ON SHEEP AND GOAT RANGES

The salting of sheep and goats is a relatively simple matter compared with the salting of cattle, since they are grazed in bands

under the care of herders at all times. Definite plans for salting sheep and goats in accordance with good range management will aid materially in keeping them contented, making them easier to herd (fig. 1), and accustoming them to new bed grounds. The plans for salting are usually incorporated in the full plans for management, which provide for the use of parts of the allotment for the period required to utilize available feed and for such bedding, shading, and watering practices as will prevent undue concentration.

For the interests of the animals, the range, and the forest, it is best to salt sheep or goats on the bed ground every evening (fig. 20), distributing no more salt than they will consume before bedding down for the night. This is usually done before they come on to the bed ground by placing salt in portable troughs or scattering handfuls of granulated salt on rocks, hard ground, or grass. Care should be taken to avoid dust, loose soil, sand, and gravel.

Sometimes it is impracticable to pack salt to each bed ground, and under such conditions sheep or goats may be salted at intervals of three to five days. If troughs are used, the longer intervals necessitate greater trough space. When the animals are fed a small quantity every night three troughs about 4 feet in length will usually be sufficient, as the sheep are never very salt-hungry and usually only a few head are around the troughs at one time. With five-day intervals many of the sheep desire salt at each salting and the troughs necessary become an item in packing which may prevent their general adoption. Furthermore, the use of troughs tends to cause longer use of bed grounds than is desirable.

When the "bedding out" system of handling sheep is used, the sheep graze quietly onto the fresh bed ground selected for the night, and finding salt bed down more contentedly than when salted at longer intervals. Where sheep or goats are bedded on each bed ground for two or three nights, salt is sometimes fed only the first night in order to aid in locating them on the new bed ground.

Occasionally sheep may be satisfactorily salted in corrals or small lots at deep-well watering places; but, in general, salting at water tends to hold sheep or goats around the water for a longer period than necessary, resulting in heavier trampling than would otherwise be the case and possibly in contamination of the water. This is particularly important about flood-water reservoirs. The increased grazing and trampling may result in range deterioration and erosion. If this occurs, the life of the reservoir may be materially shortened and excessive expenditure for silt removal required.

Sheep or goats should not be salted, bedded, or allowed to shade up on eroded areas or in clumps of timber reproduction. Even with abundant feed on the range, young timber will be injured if sheep are salted in the midst of a clump.

In developing salting plans for sheep and goat ranges, the essential features should be carefully considered on the range with the owners of the stock, and mutual agreement reached regarding salting. Definite approved written instructions can then be given the herder by the owner. Responsibility is thus fixed and less supervision by the owner or forest officer is necessary.

SUMMARY

Salt is essential in the diet of grazing animals. The quantity needed for any class of livestock on the range depends largely upon

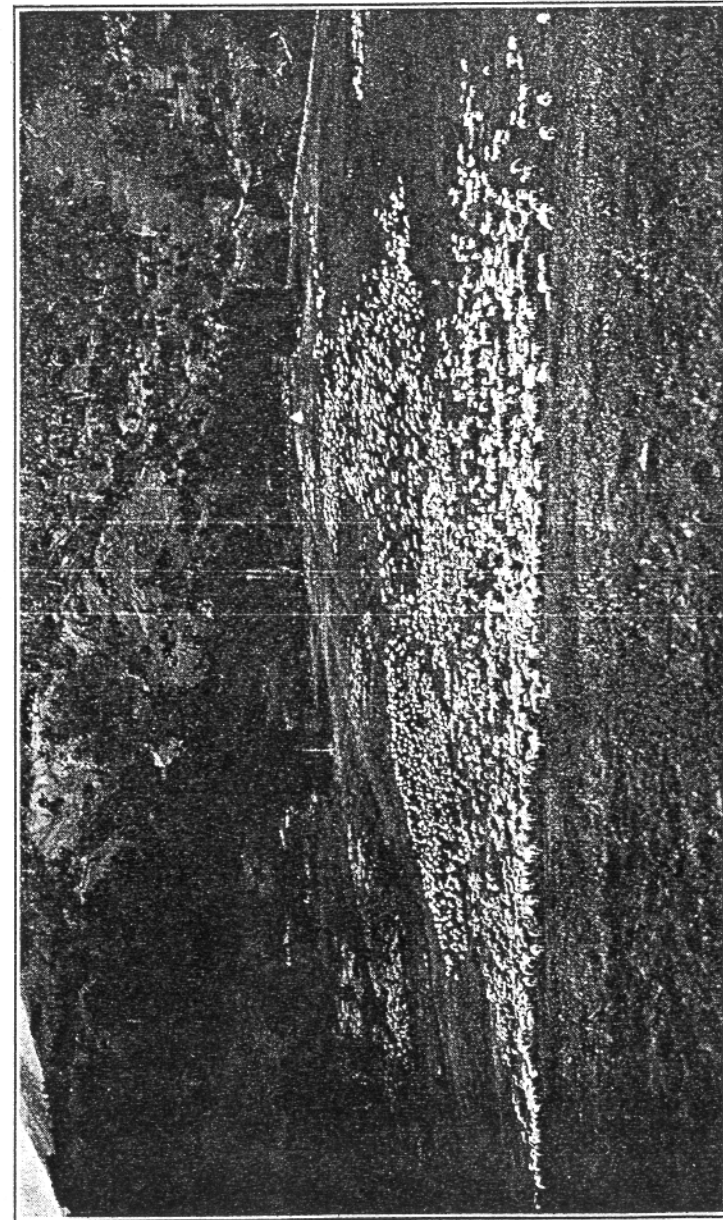

F-22046-A
 FIG. 20.—Sheep gathering on a bed ground for the night under the "bedding out" system. Ordinarily it is best to salt sheep on the bed ground every evening, in small portable troughs or on rocks, hard ground, or grass, giving them only as much as they will consume before bedding down for the night.

the salt content of feeds, salt in drinking water and natural "licks," and loss from weathering.

In general, about 2 to 2½ pounds of salt a head a month are required by cattle on average ranges when feed is succulent or when most kinds of browse plants form the bulk of the ration. During the remainder of the season 1 to 1½ pounds a month is usually adequate. Fair annual salt allowances for average year-long ranges appear to be about 20 pounds a head for cattle and 3 to 4 pounds a head for sheep and goats. Adjustments in amount must be worked out on individual ranges, because of different local conditions.

Relative cost on the range, availability, and freedom from impurities are the elements that largely determine the kind of salt to be used for cattle and horses. Granulated or crushed salt is ordinarily advisable for sheep and goats.

In Kansas a four-months test during the summer showed an average weathering loss of granulated salt of about 24 per cent a month, as compared with about 10 per cent a month for six different grades of block salt. In tests in New Mexico crushed sack salt weathered much faster than block salt. Comparatively small but variable differences in weathering were noted between samples of block or rock salt tested in Arizona; increased rainfall was reflected in a greater salt loss, and the station with the heavier precipitation of rain and snow showed a greater salt loss per inch of rainfall.

Ordinarily salt containers reduce the loss from weathering. On cattle and horse ranges troughs, logs, or boxes should be provided for crushed or granulated salt and will also pay in some cases for block or rock salt. It is seldom practicable or necessary to provide containers for all block or rock salt. Stored salt should always be protected from the weather.

Since salt attracts cattle, it can be made a most important and economical aid in the local control and distribution of cattle. Systematic salting can be used on all ranges to lessen undue bunching and overgrazing on areas where the animals tend to congregate, to increase the use of portions of range normally only lightly used, and to aid in controlling cattle locally, so that the forage of the whole grazing unit will be used to best advantage.

The use of salt can not, of course, eliminate on any range the necessity of riding or the need for major fences to provide control of the range as a whole. It is usually advisable to drive some cattle—several times if necessary—to newly established salt grounds. Satisfactory results will not usually be obtained the first season.

In locating salt grounds, areas too heavily used and those difficult of access should be avoided, and spots should be so chosen that damage to forage and young timber and to the soil from erosion will be least and that the most aid in handling may be expected. On cattle ranges salt should be placed at readily accessible places on ridges, knolls, or benches, in small openings in timber and brush, and on the more level parts of slopes. Lightly used areas and patches of less-liked forage should be favored over places usually fully grazed. The distance at which salt should be placed from water depends largely on the water distribution and abundance, topography, character of feed, condition of the range, and condition of the cattle. Salt should ordinarily be placed at a reasonable distance from water, but never

beyond a practicable walking distance. A shift in location of salt grounds should always be made in time to prevent decided damage to the range.

Under favorable conditions salt grounds may be 2 miles apart, but ordinarily better results follow a spacing of not more than 1 mile, equivalent to one ground for each 40 to 60 cattle. Where topography is rough and the grounds are used for short periods only, one for every 20 head for the full summer season may be needed. The quantity of salt allotted to each ground should be based on the grazing capacity of the area to be grazed from that ground for the desired period of use, considering both animal requirements and weathering.

Signs promote systematic salting and are needed at the more important salt grounds which compose the framework of the salting scheme; the remaining grounds may be located by well-known landmarks. Signs indicate the specific location for salt, tie to the ground the provisions of written salting plans, aid new men in distributing salt, and furnish a basis for clear discussion of all salting problems.

On national-forest ranges salt plans are very important. The cooperation of the stock owners is necessary both in building the original plan and in making the changes which are required from year to year. Plans should be simple, concise, and definite. A map of the range, showing all topographic and other features that may influence salting, is the basis of the plan. Boundaries of each small management unit may well be indicated, together with the number of stock which should graze it, dates of grazing, and location of each salt ground. Supplements to the map include a tabulated salting schedule showing the periods for salting each ground and the quantity of salt for each, and a written statement clearly defining the duties of each party to the plan—whether an individual owner or a representative of a group of owners.

The salting of sheep and goats and the making of salt plans for them is a relatively simple matter compared with the salting of cattle, since sheep and goats are usually grazed in bands under the care of herders at all times. Essential features should be carefully considered on the range with the owners, who can then give definite approved written instructions to the herders.

Where conditions permit it is best to salt sheep and goats on the bed ground every evening, giving them no more than they will consume before bedding down for the night. The salt may be placed in portable troughs or on rocks, hard ground, or grass. It is sometimes impracticable to pack salt to each bed ground, and under these conditions salt is provided at intervals of from three to five days. When the "bedding out" system of handling sheep is used, if the animals find salt on each new bed ground, they are more contented there than when salted at longer intervals.

Generally speaking, salting sheep and goats at water—particularly flood-water reservoirs—results in heavier trampling than would otherwise be the case and may cause contamination of the water. Sheep or goats should never be salted, bedded, or allowed to shade up on eroded areas or in clumps of timber reproduction.

LITERATURE CITED

- (1) ADAMS, J. A.
Reports (unpublished) in files U. S. For. Serv. 1923-24.
- (2) BARCOCK, S. M., and CARLYLE, W. L.
The addition of salt to the ration of dairy cows. 22d Ann. Rep., Wis. Agr. Exp. Sta. 1905.
- (3) CHAPLINE, W. R.
Production of goats on far western ranges. U. S. Dept. Agr. Bul. 749. 1919.
- (4) CURTISS, C. F.
Annual report. Iowa Agr. Exp. Sta. 1920.
- (5) _____
Annual report. Iowa Agr. Exp. Sta. 1924.
- (6) EVVARD, J. M., et al.
Mimeographed reports on feeding tests: Nos. D-63, 1920; D-70, D-71, 1921; D-80, 1922; D-97, 1923; D-100, 1924. Iowa Agr. Exp. Sta.
- (7) FLEMING, C. E.
One-night camps vs. established bed-grounds on Nevada sheep ranges. Nev. Agr. Exp. Sta. Bul. 94. 1918.
- (8) FORBES, E. B., BEEGLE, F. M., and MENSCHING, J. E.
Mineral and organic analyses of foods. Ohio Agr. Exp. Sta. Bul. 255. 1913.
- (9) FRAPS, G. S., and LOMANITZ, S.
The salt or sodium chloride content of feeds. Texas Agr. Exp. Sta. Bul. 271. 1920.
- (10) GOSS, A.
Ash analyses of some New Mexico plants. N. Mex. Agr. Exp. Sta. Bul. 44. 1903.
- (11) HAYNES, G. L.
Report (unpublished) in files U. S. For. Serv. 1923.
- (12) HENRY, W. A., and MORRISON, F. B.
Feeds and feeding. 1923.
- (13) HENSEL, R. L.
The best kinds and grades of salt to use. *In* Breeders' Gazette, Aug. 11, 1921.
- (14) HILGARD, E. W.
Soils. 1918.
- (15) JARDINE, J. T., and ANDERSON, M.
Range management on the national forests. U. S. Dept. Agr. Bul. 790. 1919.
- (16) PETERSON, J. L.
Cattle salting on national forest ranges, Oregon and Washington. Report (unpublished) in files U. S. For. Serv. 1924.
- (17) SAMPSON, A. W., and MALMSTEN, H. E.
Grazing periods and forage production on the national forests. U. S. Dept. Agr. Bul. 1405. 1926.
- (18) TALBOT, M. W.
Range watering places in the Southwest. U. S. Dept. Agr. Bul. 1358. 1926.
- (19) UNSIGNED.
Abs. *in* Agr. Jour. and Mining Rec., Natal, S. A. Aug. 1, 1902.
- (20) UNSIGNED.
Discussion of salting plans for district 5. Report (unpublished) in files U. S. For. Serv.

OTHER PUBLICATIONS

- JARDINE, J. T., LINDGREN, H. A., and POTTER, E. L.
Management of range grazing land. Ore. Agr. Col. Exten. Bul. 366. 1923.
- MARSH, C. D.
Stock-poisoning plants of the range. U. S. Dept. Agr. Bul. 1245. 1924.
- PARR, V. V.
Beef-cattle production in the range area. U. S. Dept. Agr. Farmers' Bul. 1395. 1925.