

Continuous Flow Microwave-Assisted Processing and Aseptic Packaging of Purple-Fleshed Sweetpotato Purees

L.E. STEED, V.-D. TRUONG, J. SIMUNOVIC, K.P. SANDEEP, P. KUMAR, G.D. CARTWRIGHT, AND K.R. SWARTZEL

ABSTRACT: Pumpable purees from purple-flesh sweetpotatoes (PFSP) were subjected to microwave heating using a 60 kW, 915 MHz continuous flow system, followed by aseptic packaging in flexible containers to obtain a shelf-stable product. Initial test runs were conducted using a 5 kW 915 MHz microwave system to measure dielectric in-line properties and examine the puree temperature profiles. The results demonstrated uniformity in heating of the puree at sterilization temperatures (>121 °C), and the dielectric constants and loss factors were within the range of published values for orange-fleshed sweetpotato purees. The pilot-scale test runs in a 60 kW microwave unit produced shelf-stable puree packages stable at room temperature. Polyphenolic content of the PFSP purees were evaluated and the results showed that while total phenolics increased (5.9%) and total monomeric anthocyanins slightly decreased (14.5%) with microwave application, antioxidant activity determined by 2,2-diphenyl-1-picrylhydrazyl (DPPH) radical scavenging activity and oxygen radical absorbance capacity (ORAC) assays did not significantly change as a result of microwave processing. Color values showed that microwave-processed samples differed from fresh puree in saturation and hue angle, but not in overall color change. PFSP purees increased in gel strength when microwave processed, packaged, and stored, but the gel could be easily disrupted into flowable purees. Overall, high-quality retention can be obtained by microwave processing and aseptic packaging of PFSP purees so that they can be used as functional food ingredients.

Keywords: anthocyanins, antioxidant capacity, aseptic processing, *Ipomoea batatas*, microwave sterilization, sweetpotato purees, total phenolics

Introduction

The characteristic color of purple-fleshed sweetpotatoes (PFSP) is due to an accumulation of mono- and diacylated forms of peonidin and cyanidin anthocyanidins (Philpott and others 2003; Terahara and others 2004). Anthocyanins from PFSP have been shown to exhibit strong radical scavenging and antimutagenic activity, significantly reduce high blood pressure, and have anti-inflammatory, antimicrobial, and ultraviolet protection effects (Yoshimoto and others 1999; Oki and others 2002; Suda and others 2003; Teow and others 2007). A process for making PFSP purees by adjusting the dry matter content of the steamed slices to 18% before grinding has been developed (Steed and Truong 2008). This process resulted in purees with a total anthocyanin content of 57.5 ± 1.5 mg cyanidin-3-glucoside equivalent/100 g fresh weight (fw) and an oxygen radical absorbance capacity (ORAC) value of 26.4 ± 1.3 μ mol trolox equivalents (TE)/g fw. With high polyphenolic content and antioxidant activities, PFSP purees have great

potential as ingredients in functional foods and nutraceutical products.

In the United States, canned and frozen purees have been produced at commercial levels from orange-fleshed sweetpotatoes for use in processed products such as breads, beverages, dehydrated flakes, patties, soups, and baby foods (Kays 1985; Fasina and others 2003). While these processing technologies can be readily applied to the PFSP purees, they each have some negative attributes. Frozen puree requires substantial investment in freezing equipment, frozen storage and transportation, as well as lengthy and poorly controlled defrosting steps before use (Coronel and others 2005). On the other hand, the high viscosity of sweetpotato purees requires a long retort time, which leads to severe overprocessing of canned purees. The Natl. Food Products Assn. (NFPA) recommends that sweetpotato puree in a 307 × 409 size can with an initial temperature of 87 °C be retorted for 84 min at 121 °C (NFPA 1996). These sterilization conditions degrade the sweetpotato puree and result in variable quality from the can wall to the center, poor color retention, high nutrient loss, and formation of off-flavors. The maximum can size is limited to size number 10, and this size limitation is a major obstruction to the wider applications of canned sweetpotato purees in the food industry. Additionally, cans are inefficient to transport (poor space utilization), difficult to open, pose a risk of operator injury, and result in disposal and recycling problems. Alternative processing technologies to overcome the stated issues could be beneficial to the food industry (Coronel and others 2005).

Recently, a continuous flow microwave-assisted aseptic process was developed for orange-fleshed sweetpotato purees and other flowable foods (Coronel and others 2005). This process has the

MS 20080402 Submitted 5/29/2008, Accepted 8/19/2008. Authors Steed, Simunovic, Sandeep, Kumar, Cartwright, and Swartzel are with Dept. of Food, Bioprocessing and Nutrition Sciences, North Carolina State Univ., Raleigh, NC 27695-7624, U.S.A. Author Truong is with U.S. Dept. of Agriculture, Agricultural Research Service, South Atlantic Area, Food Science Research Unit, North Carolina State Univ., Raleigh, NC 27695-7624, U.S.A. Direct inquiries to author Truong (E-mail: Den.Truong@ars.usda.gov).

Paper nr FSR08-10 of the Journal Series of the Dept. of Food, Bioprocessing and Nutrition Sciences, North Carolina State Univ., Raleigh, N.C. 27695-7624, U.S.A. Mention of a trademark or proprietary product does not constitute a guarantee or warranty of the product by the U.S. Dept. of Agriculture or North Carolina Agricultural Research Service, nor does it imply approval to the exclusion of other products that may be suitable.

advantage of producing a shelf-stable product, avoids long re-ort processing schedules, and maintains high puree quality. This study explored the feasibility of applying continuous flow microwave heating technology and aseptic processing to the PFSP puree to produce a shelf-stable product. The study also included an evaluation of in-line dielectric properties, heating performance of the material during microwave application, polyphenolic content, and antioxidant activity of the puree as affected by microwave processing.

Materials and Methods

Chemicals

Chlorogenic acid, Folin–Ciocalteu reagent, 2,2-diphenyl-1-picrylhydrazyl (DPPH), and Trolox (2,5,7,8-tetramethylchroman-2-carboxylic acid) were obtained from Sigma-Aldrich (Milwaukee, Wis., U.S.A.) while AAPH (2,2-azobis[2-amidino-propane] dihydrochloride) was obtained from Wako Chemicals USA (Richmond, Va., U.S.A.). All solvents and chemicals were of analytical grade.

Puree production

PFSP (Stokes Purple cultivar) were procured from Saura Pride Sweetpotatoes (Walnut Cove, N.C., U.S.A.). This new cultivar was coded NC 414 in the germplasm collections of the Sweetpotato Breeding Program, North Carolina State Univ. (NCSSU). The harvested roots (about 500 kg) were cured at 30 °C, 85% to 90% relative humidity for 7 d and stored at 13 °C, 85% to 90% relative humidity, for about 1 mo prior to shipping to the Fruit and Vegetable Pilot Plant, Dept. of Food, Bioprocessing, and Nutrition Sciences, NCSSU. The roots were tumble washed, sliced to 0.65 cm thickness (Louis Allis Co. Slicer, Milwaukee, Wis., U.S.A.), and steam cooked (steam at 100 °C, atmospheric pressure) for 20 min in a thermoscrew steam cooker (Rietz Manufacturing Co., Santa Rosa, Calif., U.S.A.). A ribbon mixer (Keebler Engineering Co., Chicago, Ill., U.S.A.) was used to mix the cooked slices and added water to adjust dry matter content to 18.1% (Steed and Truong 2008). This mixture was then pureed using a hammer mill (Model D, Fitzpatrick Co., Chicago, Ill., U.S.A.) fitted with a 0.15-cm screen. Puree samples were placed in 5-gallon buckets, sealed with lids, and frozen at –20 °C until later use. Moisture content of the samples was determined by oven drying at 105 °C for 24 h following AOAC (2006) method 934.01.

5-kW test runs

A 5-kW continuous flow microwave system (Industrial Microwave Systems, Morrisville, N.C., U.S.A.) was used to evaluate how purees reacted to microwave heating and whether they were suitable for scale up to an industrial system. The system consisted of a 5-kW microwave generator operating at 915 MHz, a waveguide of rectangular cross section, and a specially designed focused applicator as described by Kumar and others (2007). Puree was pumped using a positive displacement pump (Model MD012, Seepex GmbH + Co, Bottrop, Germany) with a variable speed motor (Tri-Clover Rotary Pump, Model PRE3-1M, Ladish Co., Kenosha, Wis., U.S.A.) at a rate of 0.9 L/min through a tube of 1.5" nominal diameter (0.038 m ID) made of polytetrafluoroethylene (PTFE or Teflon®) placed at the center of the applicator. Temperatures at the inlet and outlet of the applicators were monitored using a thermocouple arrangement designed by Coronel and others (2003) and a data logging system (Model DAS-16, Keithley Metrabyte Inc., Taunton, Mass., U.S.A.). A dielectric probe (HP 85070E) was inserted at the outlet of the applicator in 1 of the 3 ports of the smart gasket to measure dielectric constant and dielectric loss factor (Kumar and

others 2007). PFSP puree was continuously circulated until a centerline exit temperature of 135 °C was reached. Duplicate runs were conducted.

60-kW scale-up

Scale up to the 60 kW system involved heating the puree to 65 °C with a tubular heat exchanger using hot water (85 °C) as the heating medium. The puree was then loaded into the hopper of a 60 kW continuous flow microwave-heating unit (Industrial Microwave Systems, Morrisville, N.C., U.S.A.) operating at 915 MHz. Microwaves were generated and delivered to the puree by a waveguide of rectangular cross section which was split into 2 sections and led to 2 specially designed cylindrical applicators (Drozd and others 2001). A high purity alumina ceramic-reinforced PTFE tube was placed at the center of each applicator and had a corresponding exposure region of 0.2 m.

A positive displacement pump (Model A7000, Marlen Research Corp., Overland Park, Kans., U.S.A.) pumped the puree through the system at a flow rate of 5.7 L/min. Temperatures were measured at the inlet and outlet of the system and each applicator by a thermocouple arrangement described by Coronel and others (2003). The target temperature at the outlet of the system was achieved by controlling the power to the microwave system, which varied from 25 to 30 kW.

The product was heated to 135 to 145 °C, held for 30 s, cooled using a tubular heat exchanger, and then aseptically packaged in aluminum-polyethylene laminated bags (Scholle Corp, Chicago, Ill., U.S.A.) using a bag-in-box unit (Model PT A.F, Astepo, Parma, Italy). Duplicate runs of microwave processing in the 60 kW system were carried out for PFSP purees. Aseptically packaged puree was stored at room temperature (22 °C) until analyzed.

Thermal death time calculations

Thermal death time or F_0 value was calculated for both 60 kW runs using the following equation:

$$F_0 = \int_0^t 10^{\left(\frac{T-T_{\text{ref}}}{z}\right)} dt$$

where T is the temperature (°C), and t is the processing time spent at temperature T . The reference temperature (T_{ref}) was 121.1 °C with a z -value of 10 °C, which correspond to the values for *Clostridium botulinum* (Datta 2000; Brinley and others 2007). The T -value used for both runs was the lowest recorded minimum temperature at the center of the hold tube, which ensured the most conservative F_0 value for the process.

Sampling

Two separate runs were conducted in both the 5 and 60 kW microwave systems. Duplicate samples were taken at each stage of the microwave process: fresh puree production, puree processed in the 5 kW system, puree pre-heated by tubular heat exchanger, and puree processed in the 60 kW microwave system. The weighed samples were frozen at –80 °C and lyophilized in a VirTis Genesis 25XL freeze dryer (Gardiner, N.Y., U.S.A.) that operated at –35 to –40 °C. The samples were weighed and ground into powder using a Mr. Coffee® precision coffee grinder (Sunbeam, Boca Raton, Fla., U.S.A.), then placed in sample vials and kept in –80 °C storage until analysis.

Microbiological testing

An aseptic bag from each 60 kW run was incubated at 37 °C and observed for changes in the appearance of the bags for 14 d. After

this observation period, another aseptic bag from each run was sent to Silliker Labs Inc. (Cedar Rapids, Iowa, U.S.A.) for microbiological testing to verify the commercial sterility of the product. The aerobic plate counts were enumerated using AOAC (2006) methods 966.23-966.25, while mesophilic anaerobic spores, thermophilic aerobic spores, and thermophilic anaerobic spores were enumerated using protocols from the Compendium of Methods for the Microbiological Examination of Foods (Downes and Ito 2001).

Color measurements

Hunter $L^*a^*b^*$ values were measured with a Hunter colorimeter (D25/DP9000 Tristimulus Colorimeter, Hunter Associate Laboratories Inc., Reston, Va., U.S.A.). The puree samples were filled into a 35-mm petri dish, covered, and pressed against the surface to remove air bubbles. The colorimeter was calibrated against a standard white tile ($L^* = 92.75$, $a^* = -0.76$, $b^* = -0.07$) and sample measurements were taken at 3 different locations, with duplicates performed for each sample. Averages of these readings are reported. Hue angle (h°) was calculated using $\arctan(b^*/a^*)$, chroma (C^*) as $[\alpha^{*2} + b^{*2}]^{1/2}$, and color change (ΔE) as $(\Delta L^*)^2 + (\Delta a^*)^2 + (\Delta b^*)^2)^{1/2}$.

Rheological testing

The gel properties of fresh and microwave-processed purees were evaluated by small amplitude oscillatory rheology (SAOR) using a stress-controlled ATS Stresstech Rheometer (Rheosystems, Bordentown, N.J., U.S.A.) outfitted with parallel plate (20 mm dia) geometry. Frequency sweeps were conducted for a range of 0.1 to 20 Hz with stress held constant at 20 Pa, which was within the linear viscoelastic region. Fresh puree samples were evaluated under a gap height of 1.5 mm. For microwave-processed purees, cylindrical samples (diameter = 25 mm) were taken at room temperature using a metal cylindrical punch. This cylinder was then trimmed to 3.5 mm thickness and the cylindrical samples were glued (Loctite 401 Instant Adhesive, Henkel Corp, Louisville, Ky., U.S.A.) to the upper and lower plate of the rheometer with a gap of 3 mm. The diameter of the cylinder was trimmed to match the parallel plate and edges were covered with lubricant (Super Lube[®], Bohemia, N.Y., U.S.A.) to prevent moisture loss from the sample. Measurements were taken at 25 °C and the G modulus was examined for gel characteristics.

Analysis of phenolic content and antioxidant activities

Preparation of the extracts. Extraction of polyphenolic compounds from freeze-dried sweetpotato powders was performed using an accelerated solvent extractor (Dionex ASE 200, Sunnyvale, Calif., U.S.A.) equipped with a solvent controller. Three cellulose filters were placed in the bottom of a 22 mL stainless steel extraction cell and covered with 2 g of sea sand (Fisher Scientific, Pittsburgh, Pa., U.S.A.). Sweetpotato powder (0.25 g) was mixed with 26 g of sand, loaded into the cell and then sealed tightly. Extraction parameters for all extracts were set as previously described by Steed and Truong (2008). Extracts were collected in UV-proof glass vials, adjusted to 50 mL volume with solvent, dispersed into 10 mL serum tubes and kept at -80 °C until analysis.

Quantification of total phenolics and anthocyanins. Total phenolic compounds were quantified using a modified Folin-Ciocalteu (FC) method with chlorogenic acid as the standard (Singleton and others 1999). Samples and standards (0.25 mL) were diluted in 4 mL of water to which 0.5 mL of the FC reagent was added and allowed to react for 3 min. Then, 0.5 mL 1 N sodium carbonate was added and allowed to react for 1 h. Samples were read

for absorbance at 725 nm using a Varian Spectrophotometer (Cary WinUV Model 300, Palo Alto, Calif., U.S.A.). The spectrophotometer was calibrated with a blank that contained 0.25 mL water instead of sample, along with the same amount of water for dilution, FC reagent, and sodium carbonate solution. Total phenolic values were reported in mg chlorogenic acid equivalents per 100 g fresh weight (mg CAE/100 g fw).

Total monomeric anthocyanin content was determined using the pH-differential method (Guisti and Wrolstad 2001). Two dilutions were performed on each sample. The first used potassium chloride (0.025 M) at pH 1 and the second used sodium acetate (0.4 M) at pH 4.5. Samples were diluted so that absorbance readings at 530 nm were less than 1.2. They were allowed to equilibrate for 15 min before absorbances at 530 and 700 nm were recorded using a spectrophotometer calibrated with distilled water as the blank. The difference in absorbance between pH values and wavelengths was calculated:

$$A = (A_{530\text{nm}} - A_{700\text{nm}})_{\text{pH}1.0} - (A_{530\text{nm}} - A_{700\text{nm}})_{\text{pH}4.5}$$

The A value was used to calculate monomeric anthocyanin concentration using:

$$\text{Monomeric anthocyanin pigment} \\ (\text{mg/L}) = (A \times MW \times DF \times 1000) / (\epsilon \times 1)$$

where MW is the molecular weight, DF is the dilution factor, ϵ is the molar absorptivity, and 1 is for a standard 1 cm path length. The molecular weight ($MW = 449.2$) and molar absorptivity ($\epsilon = 26,900$) for cyanidin-3-glucoside were used. Total monomeric anthocyanins were reported as mg anthocyanins per 100 g fresh weight or dry weight (mg cyaniding-3-glucoside/100 g fw or dw).

Assay of DPPH radical scavenging activity. Antioxidant activity determined by the DPPH assay is based on the methodology of Brand-Williams and others (1995). Trolox was used as a standard and concentrations ranging from 0 to 500 μM were used to create a standard curve. Samples were diluted 10-fold and then 100 μL sample or standard was added to 1.9 mL of DPPH solution and allowed to react for 3 h (Teow and others 2007). Absorbances of standards and samples were read at 515 nm with a spectrophotometer. Results were expressed in μmol trolox equivalents per gram fresh weight ($\mu\text{mol TE/g fw}$).

Oxygen radical absorbance capacity (ORAC). The ORAC procedure established by Prior and others (2003) was followed. Fluorescence intensity measurements were performed using a Safire monochromator based microplate reader equipped with Magellan V4-W reader software (Tecan USA, Research Triangle Park, N.C., U.S.A.). Samples were loaded into 96-well transparent Costar polystyrene flat bottom plates (Corning, Acton, Mass., U.S.A.). The wells were filled with 70 μL of phosphate buffer, 60 μL of fluorescein solution, and 60 μL of standard or sample (100-fold dilution). For blank wells, phosphate buffer was used in place of the sample. The plate was incubated at 37 °C for 15 min before 60 μL of AAPH was rapidly added to each well. Plates were shaken orbitally for 5 s at the start and between 1 min reading intervals. Measurements were performed with 80 cycles using excitation and emission filter wavelengths of 485 and 520 nm, respectively (Steed and Truong 2008). The values were calculated as described by Prior and others (2003) and ORAC values were expressed in μmol trolox equivalents per gram of fresh weight ($\mu\text{mol TE/g fw}$).

Statistical analysis

The experiments were performed with 2 replicates and duplicate samples were taken from each replicate for all analysis. Group

differences were evaluated using analysis of variance (ANOVA) *F*-tests using the SAS v8.1 (SAS Inst. Inc., Cary, N.C., U.S.A.) with $P < 0.05$ considered to be a statistically significant difference. Means were separated by the Student–Newman–Keuls (SNK) procedure. This was chosen due to the unequal sample sizes of the lab samples and this procedure accounts for that by using the harmonic mean. The SNK procedure is less conservative than other methods of means separation, which means that it is more likely to declare a difference between values.

Results and Discussion

In-line dielectric properties and temperature profiles of PFSP puree

PFSP purees were processed in a 5 kW microwave unit to determine the suitability of the materials for microwave processing based on temperature profiles and in-line dielectric properties. Inlet temperatures showed uniformity at the center, intermediate, and walls of the heating tube (Figure 1A). At the initial stages of microwave heating, larger temperature differences (10 to 20 degrees) were noted for the outlet streams, especially between the center/intermediate space and the walls (Figure 1B). As microwave heating increases the temperature of the puree to sterilization (121 °C) the temperature differences among these streams reduced (Figure 1B). Smaller temperature differences at the outlet streams are indicative of increased uniformity in heating of the puree at sterilization temperatures and above.

The dielectric properties of PFSP purees were measured under continuous flow conditions with a probe placed at the exit of the applicator in the 5 kW system. Dielectric constant (ϵ') and dielectric loss factor (ϵ'') with respect to temperature are shown in Figure 2. The values of ϵ' decrease with an increase in temperature which is in accordance with the observations of Datta and others (1997) for food products with greater than 60% moisture.

Also, it is established that dielectric constant decreases with increasing temperature due to a decrease in dielectric relaxation time. Relaxation time is associated with the time for the dipoles to revert to random orientation when the electric field is removed and decreases as temperature increases (Sumnu and Sahin 2005). Dielectric constant decreased from 70.4 at 20 °C to 47.7 at 135 °C. These values were slightly higher than those reported by Brinley and others (2007) for purees made from the Okinawa and NC 415 purple-fleshed cultivars which were measured under static conditions. Since Kumar and others (2007) demonstrated the similarity of dielectric properties measured under static and continuous conditions for vegetable purees, the discrepancy can be attributable to the differences in moisture content among the purees. Brinley and others (2007) did not dilute the purees to make them flowable and the dry matter content of the Okinawa and NC 415 purees were 30% and 32%, respectively, as compared to 18.1% for the puree prepared in this study. Dielectric constant values for PFSP purees were very close to those reported for orange-fleshed sweetpotatoes (Coronel and others 2005; Brinley and others 2007). This was favorable since the viscosity of PFSP puree was adjusted to mimic that of an orange-fleshed sweetpotato puree. Viscosity and moisture content are among the main factors that affect dielectric properties in microwave processing. Brinley and others (2007) reported that moisture content had a significant effect on dielectric constant of sweetpotato purees derived from various cultivars. An increase in free water in the puree will lead to an increase of the number of polar molecules that will re-orient with changes in electric field to cause an elevated dielectric constant (Sumnu and Sahin 2005).

Dielectric loss factor was shown to increase with an increase in temperature which was also in accordance with the previous reports (Datta and others 1997). Ionic conductivity and dipole rotation both contribute to the increase in dielectric loss factor (Wang and others 2003). Herve and others (1998) showed that the reduction in viscosity of cottage cheese at higher temperatures led to an increased mobility of ions and electrical conductivity to ultimately cause an increase in heating. Dielectric loss factor values increased from 14.1 at 20 °C to 39.4 at 135 °C for the PFSP (Figure 2). These values are similar to those of purple-fleshed and orange-fleshed sweetpotato purees (Coronel and others 2005; Brinley and others 2007).

The results of the 5 kW test runs indicated that PFSP puree was interacting with microwave heating in a similar manner to orange-fleshed sweetpotato purees. Therefore, processing and aseptic packaging of the PFSP puree in a 60 kW microwave system would be highly feasible as is demonstrated in the following section.

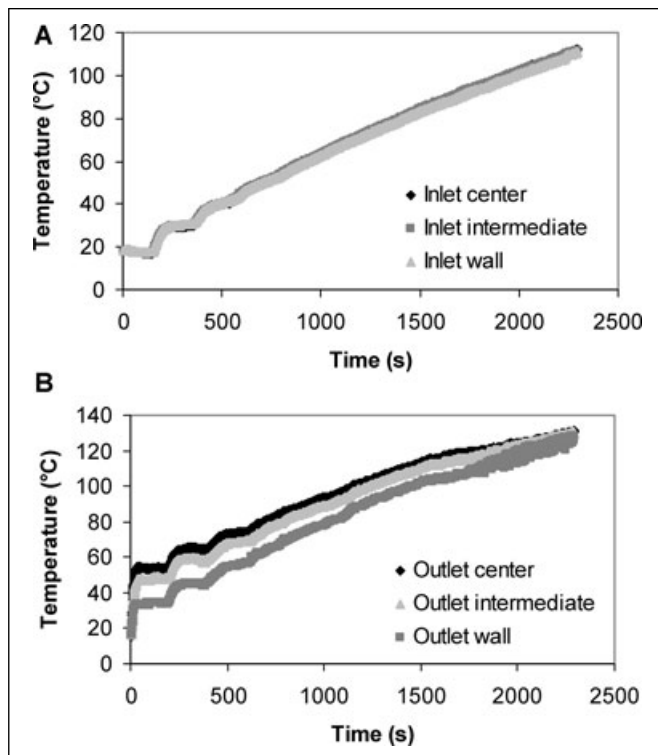

Figure 1—Time–temperature data for (A) inlet streams and (B) outlet streams during 5 kW processing.

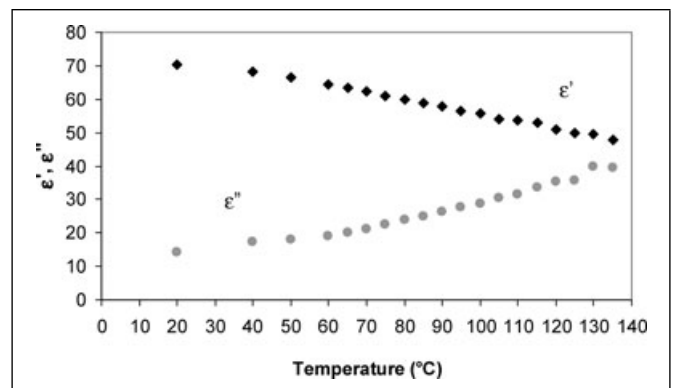

Figure 2—5 kW in-line dielectric measurements for purple-fleshed sweetpotato puree.

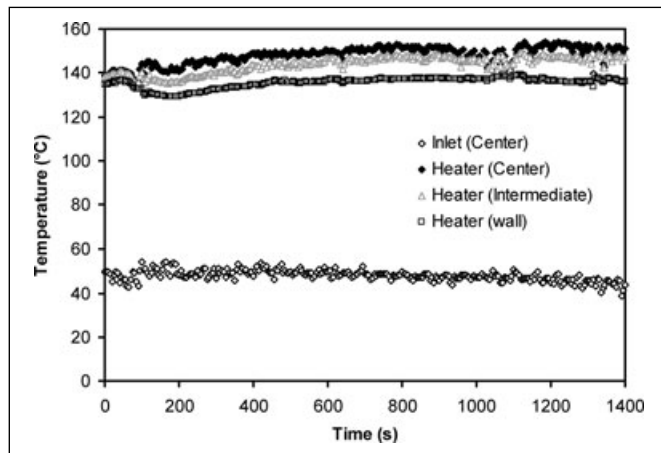
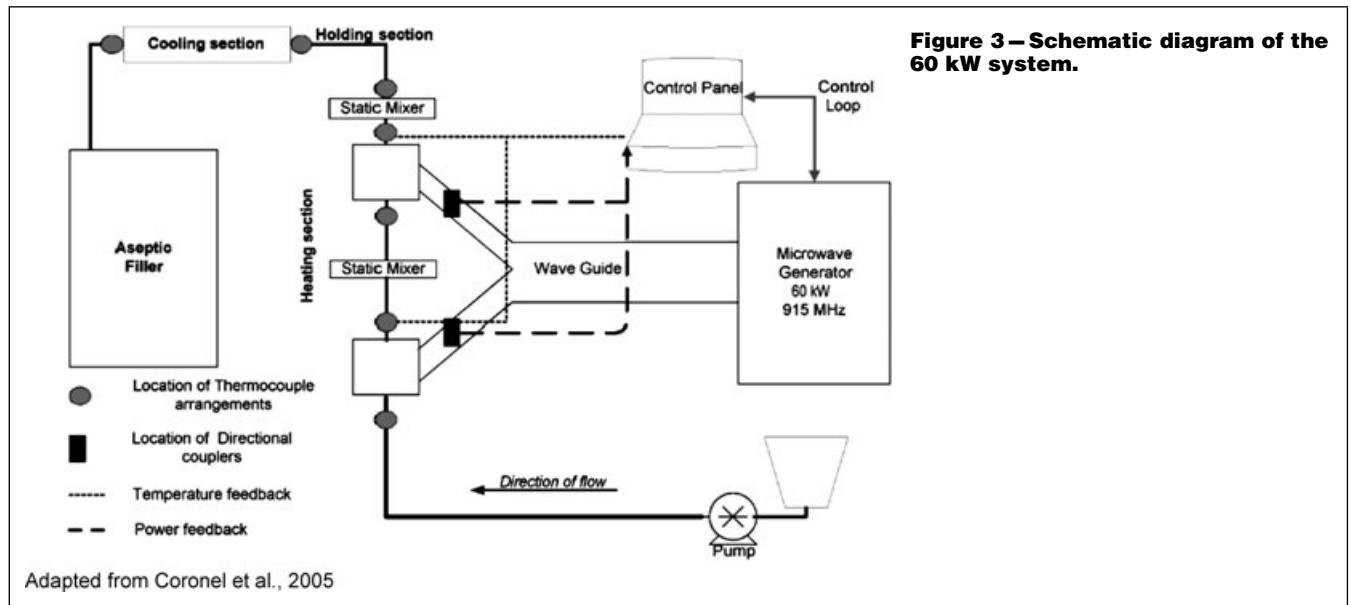

Figure 4 – Typical time-temperature history at the inlet of the microwave heating section and outlet of 2nd microwave applicator (Run 1).

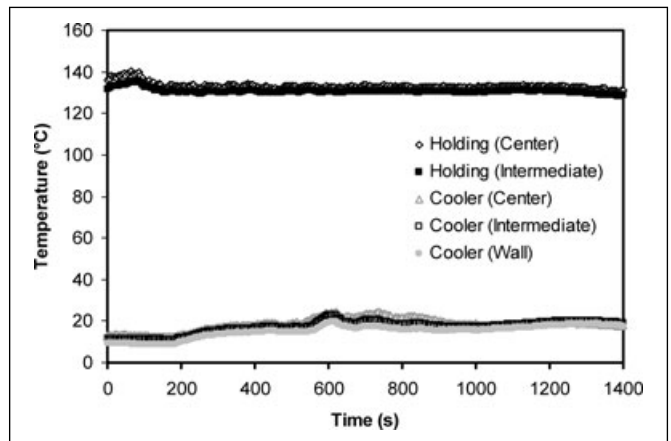

Figure 5 – Typical time-temperature history at the exit of the holding and cooling sections (Run 1).

60-kW microwave processing

The temperature of PFSP puree was measured with thermocouple arrays positioned at the inlet of the system, the outlet of each applicator and the inlet and exit of the holding tube (Figure 3). Figure 4 and 5 show time-temperature profiles recorded during microwave processing of PFSP puree during the 1st run. The puree entered the microwave heating section at about 50 °C and exited the 2nd applicator at a target temperature of 135 to 150 °C (Figure 4). PFSP passed through the heating section at a flow rate of about 4.0 L/min and spent an estimated 25 s in the 2.4 m holding tube (ID = 0.0229 m). Outlet temperatures for the cooling section indicated that puree was pumped out of the system at 10 to 20 °C (Figure 5). This temperature was too low and led to a thickening of the puree resulting in large increase in the back pressure of the microwave system. For a batch of sweetpotato roots, which were not properly cured after harvesting, the high starch content in the puree resulted in gel formation that clogged the system and increased the back pressure to dangerous levels. With this experience, the cooling temperature was maintained at 40 °C in the duplicate test run and the system ran without any problems (Figure 6). On this 2nd run, there was a greater temperature difference between the center and intermediate space of the holding tube (Figure 6).

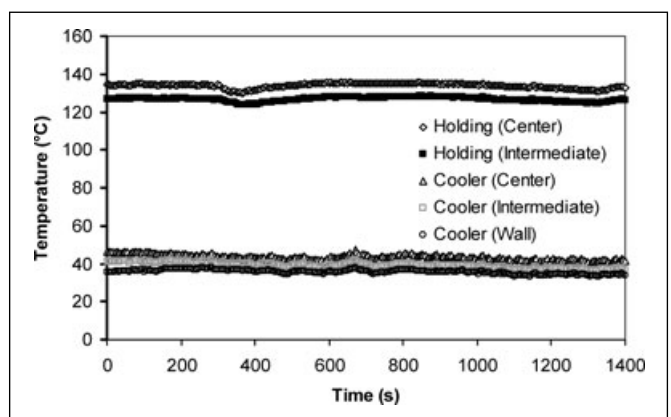

Figure 6 – Typical time-temperature history at the exit of the holding and cooling sections (Run 2).

The F_0 values were calculated based on the time-temperature history of the holding tubes. For run 1, F_0 value at the center for the fastest liquid particle was 2.97 min, while for run 2 this value was 3.70 min. This is logical because the center temperature of the holding tube for run 2 was consistently a few degrees higher than the

Table 1—Hunter color values of purple-fleshed sweetpotato puree as affected by preheating and microwave processing.

Sample	L^*	a^*	b^*	Hue	Chroma	ΔE^c
Puree ^A	20.3 ± 0.1 ^{b*}	26.2 ± 0.1 ^a	-13.3 ± 0.1 ^a	-26.9 ± 0.2 ^b	29.4 ± 0.1 ^a	—
5 kW	20.6 ± 0.1 ^a	23.2 ± 0.1 ^b	-9.3 ± 0.0 ^d	-21.8 ± 0.1 ^a	25.0 ± 0.1 ^b	5.1 ± 0.1 ^a
Pre-heated ^B	19.3 ± 0.0 ^c	21.6 ± 1.3 ^b	-10.6 ± 0.3 ^b	-26.8 ± 0.8 ^b	24.1 ± 1.3 ^b	5.7 ± 1.2 ^a
60 kW	19.2 ± 0.1 ^c	22.1 ± 1.3 ^b	-8.0 ± 0.3 ^c	-20.7 ± 0.1 ^a	23.5 ± 1.3 ^b	7.7 ± 1.0 ^a

^APuree made from steamed slices adjusted to 18% dry matter content.

^BPreheated: puree heated to 65 °C before 60 kW microwave.

^C ΔE calculated using the average values of L^* , a^* , and b^* for puree.

*Values reported are means of two replicates ± the standard error of the mean. Superscripts signify significance based on ANOVA F -tests with Student–Newman–Keuls means separation.

center temperature of the holding tube in run 1. Higher processing temperatures will result in increased F_0 values, at identical product flow rates. Furthermore, these F_0 values fall within the range reported by Brinley and others (2007) of 0.65, 2.80, and 10.10 min for target temperatures of 126, 132, and 138 °C, respectively.

Microbiology

Aseptic pouches incubated at 37 °C were monitored for 2 wk for changes in appearance. This environment was used to mimic conditions most favorable for thermophilic spoilage which would indicate inadequate processing for commercial sterility. Thermophilic spoilage would result in gas production and cause an expansion of the bag. Since there was no visible change noted after 2 wk of incubation, it was likely that the thermal treatment was adequate. Microbiological results from Silliker Laboratories reported 1 aerobic plate count at 30 per gram while the other 2 fell below 10 per gram. Mesophilic anaerobic spores reported < 3 per gram, thermophilic aerobic spores were < 5 per gram and thermophilic anaerobic spores were negative (positive in 0/6 tubes), which were all below the detection limits for the analytical tests. Since aerobic plate counts will rarely enumerate organisms of concern in thermal processing, colonies that formed could be due to less important spoilage organisms that somehow survived the microwave process or are due to some form of postprocess contamination.

Color values

The difference in anthocyanin content between samples was reflected in the Hunter $L^*a^*b^*$ values and summarized in Table 1. L^* is a lightness index and ranges from 0 to 100 with 0 representing black and 100 representing white. The preheated and 60 kW microwave-processed samples were significantly ($P < 0.05$) darker than the untreated puree and 5 kW samples. However, the preheated and 60 kW samples are not significantly different from one another, which suggest that the decrease of lightness occurred during the preheating step and was not advanced by microwave processing. The 5-kW puree sample was the lightest, which was expected due to the continual recirculation and therefore a much higher cumulative thermal treatment received by the puree. This was in accordance with an increase in L^* values for strawberry purees that underwent microwave treatment for longer periods of time (Ancos and others 1999). The intensity of red color is represented by a^* value while blue color is represented by a negative b^* value, and together, these components contribute to purple color. Both red and blue intensity decreased for PFSP samples processed by microwave heating.

Puree and preheated samples had higher hue angles signifying a more blueish purple color than microwave-processed samples. Fresh puree also had a significantly higher ($P < 0.05$) chroma value showing an increase in saturation of purple color (Table 1). Microwave processing caused a decrease in hue angle and saturation; however, the overall color change, represented by ΔE (Table 1),

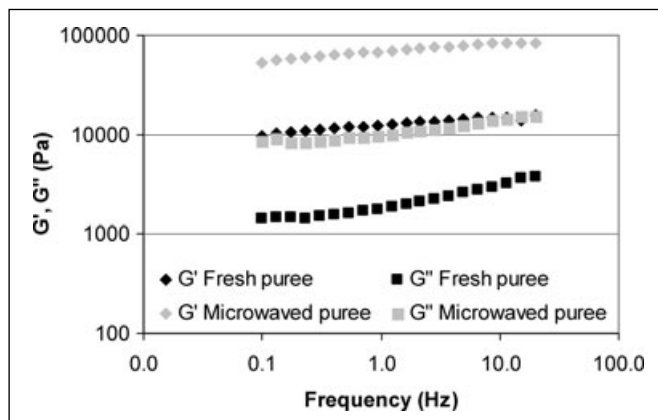
**Figure 7**—Comparison of G' and G'' for fresh and 60 kW microwave-processed puree.

was not significant for the preheated and microwave-processed samples.

Rheological testing

When the samples tested in the 5 kW microwave cooled it was noticed that the puree strengthened its gel networks. Samples processed in the 60 kW system exhibited the same behavior upon storage. Therefore, small amplitude oscillatory rheology (SAOR) was performed to obtain the G^* modulus which has 2 components, G' the storage modulus or elastic component and G'' the loss modulus, or viscous component. Viscoelastic materials are further defined by the relationship between G' and G'' . Gel behavior is described by the parallel slopes of G' and G'' with G' greater than G'' throughout the frequency range. This illustrates a dominance of the solid behavior for the viscoelastic material (Steffe 1996). The G' and G'' values as a function of frequency of the fresh puree and puree that has been processed in a 60 kW system are shown in Figure 7.

The G' values for puree and 60 kW microwave-processed puree are greater than their G'' counterparts, and all run parallel to one another (Figure 7). However, the G' and G'' values for 60 kW microwave-processed puree are nearly a magnitude greater than the values for fresh purees. Values for G' and G'' of PFSP puree were similar but slightly higher than values reported by Fasina and others (2003) for orange-fleshed sweetpotato puree. Orange-fleshed sweetpotato puree only exhibited slight gel strengthening due to microwave processing, so this phenomenon is most likely linked to a difference in carbohydrate components present in the 2 cultivars. Depending on the utilization of the aseptic purees, an increase in gel strength can be a negative or positive attribute. For utilization in products such as pies, cakes, and mashed sweetpotatoes, purees with high gel strength would result in products with desired textural properties. It was also observed that the gel network in the aseptic

PFSP puree can be disrupted easily by mechanical disturbance and the flow ability of the purees returned.

Polyphenolic content and antioxidant activity

Total phenolics. Total phenolic content ranged from 313.6 to 353.8 mg CAE/100 g fw for PFSP puree and 60 kW microwave samples, respectively (Table 2). Phenolic content for the 60 kW microwave-processed samples was significantly higher (5.9% to 12.8%) than all other samples evaluated. This increase places 60 kW microwave-processed puree closer to the range found for raw and steamed flesh and whole PFSP roots (Steed and Truong 2008). These values are much higher than the total phenolic content range of 78.6 to 181.4 mg CAE/100 g fw for orange-fleshed sweetpotatoes (Truong and others 2007). However, the phenolic contents of red-fleshed sweetpotato and purple carrot are much higher and are reported as 945 and 1756 mg CAE/100g fw, respectively (Cevallos-Casals and Cisneros-Zevallos 2003).

Generally, thermal processing to sterilization levels results in a decrease of phenolic content. Strawberry phenolic content decreased by almost 50% from 61 to 35.6 mg galic acid equivalents (GAE)/100 g fw, while canned wild and cultivated blueberry products also exhibited significant decreases in phenolic compounds (Klopotek and others 2005; Schmidt and others 2005). However, hot air dried tomatoes had a significant increase of 13% and 29% in total phenolics as referred to the fresh samples from 2 different cultivars, respectively (Chang and others 2006). Oregano treated by industrial microwaves was also shown to increase in total phenolic content from 112.1 to 135.3 mg GAE/g fw (Bertelli and others 2004). Pepper and basil increased in phenolic content as well, though not significantly. Microwave application has also been shown to stimulate the production of phenolic compounds by 700% when applied to germinated sprouts of fava beans (Randhir and Shetty 2004). These reports are in agreement with a 12% increase in total phenolic content of the 60 kW microwave samples as compared to the fresh puree (Table 2). An increase in phenolic content could be due to the liberation of phenolic compounds from the matrix during food processes. Phenolic compounds are secondary metabolites that usually accumulate in the vacuoles. The breakdown of cellular membranes resulting from food processing could lead to an accelerated release of bound phenolic compounds (Chang and others 2006).

Total monomeric anthocyanins. Total monomeric anthocyanins decreased from 57.5 for fresh puree, to 53.9 for a pre-heated sample, and finally to 46.1 mg/100 g fw for samples processed in the 60 kW system (Table 2). Each step of processing caused a significant ($P < 0.05$) decrease in anthocyanin components. Both 5 and 60 kW microwave treatments showed the same level of degradation. Compared with the preheated sample, 60 kW microwave processing and

aseptic packaging resulted in a loss of 14.5% monomeric anthocyanins. Ancos and others (1999) reported that strawberry purees maintained anthocyanin content when treated by microwaves at powers ranging from 285 to 850 W for 15, 30, 45, and 60 s. However, microwaves operating at 2450 MHz, which were utilized for this study, are known to deliver less power and have a smaller penetration depth than those industrial microwave systems that operate at 915 MHz (Singh and Heldman 2001).

Anthocyanins are present in a wide range of fruits, including most berries and some vegetables. Wu and others (2006) reported that chokeberries and elderberries have the highest anthocyanin content of all food commodities examined with 1480 and 1375 mg anthocyanins/100g fw, respectively. Red-fleshed potatoes have up to 25.5 mg anthocyanins/100 g fw, while red-fleshed sweetpotatoes are much higher with 182 ± 2 mg anthocyanins/100 g fw (Rodriguez-Saona and others 1998; Cevallos-Casals and Cisneros-Zevallos 2003). PFSP purees (fresh and microwave-processed samples) were on the lower end of the spectrum having anthocyanin contents comparable to black bean, red onion, and strawberries that range from 41.7 to 48.5 mg/100 g fw. While these are lower values, they are still greater than anthocyanin contents found in apples and red grapes, which are 12.3 and 26.7 mg/100 g fw, respectively (Wu and others 2006).

Antioxidant activity. Based on the DPPH assay, antioxidant activity ranged from 47.0 to 50.2 $\mu\text{mol TE/g fw}$ for puree and 5 kW samples, respectively (Table 2). No sample showed significantly ($P < 0.05$) lower or higher antioxidant activity. These DPPH values are about half of what was reported for raw peels of PFSP in earlier studies (Steed and Truong 2008). While the process of transforming whole PFSP roots into puree causes a decrease in antioxidant activity due to the dilution of steamed slices with water, it is important to note that once puree is formed and microwave processed, there is no further decrease. This means that despite increases in total phenolic content and decreases in total monomeric anthocyanins; microwave application had no effect on antioxidant activity as determined by the DPPH assay.

This range of DPPH values for microwave-processed samples was on the higher end of DPPH radical scavenging values from 8.6 to 49.0 $\mu\text{mol TE/g fw}$ for a group of 16 purple-fleshed cultivars reported by Oki and others (2003). Kano and others (2005) reported that the DPPH radical scavenging activity of a PFSP cultivar, Ayamurasaki, was higher than those of red cabbage, grape skin, elderberry, or purple corn. This is an important finding as PFSP do not have an anthocyanin content as high as elderberry and purple corn. Orange-fleshed sweetpotatoes (cultivar Beauregard) have lower DPPH values ranging from about 2.0 $\mu\text{mol TE/g fw}$ for flesh to 7.1 $\mu\text{mol TE/g fw}$ for peels, and as great as 38.2 $\mu\text{mol TE/g fw}$ for leaves (Truong and others 2007).

Table 2—Total phenolic, anthocyanin, and antioxidant values purple-fleshed sweetpotato puree and microwave-processed samples.

Sample	Dry matter ^A	TP ^B	TMA ^C	DPPH ^D	ORAC ^E
Puree ^F	18.1	313.6 \pm 4.6 ^{bH}	57.5 \pm 1.5 ^a	47.0 \pm 2.6 ^a	26.4 \pm 1.3 ^a
5 kW	17.7	329.1 \pm 5.5 ^b	46.4 \pm 1.3 ^c	50.2 \pm 2.0 ^a	26.7 \pm 1.1 ^a
Preheated ^G	18.3	333.9 \pm 4.4 ^b	53.9 \pm 1.3 ^b	49.2 \pm 2.2 ^a	25.9 \pm 0.8 ^a
60 kW	18.2	353.8 \pm 7.4 ^a	46.1 \pm 0.7 ^c	49.2 \pm 2.0 ^a	26.8 \pm 0.6 ^a

^ADry matter determined by AOAC oven drying method.

^BTP: Total phenolics values expressed in mg CAE/100 g fw.

^CTMA: Total monomeric anthocyanin values expressed as mg cyanidin-3-glucoside/100 g fw.

^DDPPH values expressed as $\mu\text{mol TE/g fw}$.

^EORAC values expressed as $\mu\text{mol TE/g fw}$.

^FPuree made from steamed slices adjusted to 18% dry matter content.

^GPreheated: puree heated to 65 °C before 60 kW microwave.

^HValues reported are means of 2 replicates \pm the standard error of the mean. Superscripts signify significance based on ANOVA *F*-tests with Student–Newman–Keuls means separation.

The ORAC values ranged from 25.9 to 26.8 $\mu\text{mol TE/g fw}$ for preheated and 60 kW samples, respectively (Table 2). The ORAC values followed the same trend as the DPPH values in that microwave-processed samples maintained the antioxidant activity of their fresh puree counterparts. Based on ORAC values previously reported, fresh puree and microwave-processed samples are capable of a third of the amount of radical scavenging capacity as peels and about half as much as flesh and whole root samples (Steed and Truong 2008).

The ORAC values for the puree samples are below what have been reported for cranberries and lowbush blueberries with ORAC values of 92.6 and 92.1 $\mu\text{mol TE/g fw}$, respectively (Wu and others 2004). However, the range of ORAC values in Table 2 for PFSP puree and microwave samples compared well with fuji and gala apples found to have 25.7 and 28.0 $\mu\text{mol TE/g fw}$, respectively (Wu and others 2004).

Conclusions

Purple-fleshed sweetpotato (PFSP) puree was successfully processed and aseptically packaged using a continuous flow microwave system. Total phenolic content showed a 5.9% increase, while total anthocyanins decreased by 14.5% due to microwave sterilization. The decrease in anthocyanins resulted in a slight loss of saturation in blueish purple color of the puree; however, the overall color change (ΔE) due to microwave processing was not significant. DPPH and ORAC radical scavenging assays showed that despite changes in polyphenolic content and color, PFSP purees maintained their antioxidant activity during microwave processing. The gel strength of puree was increased by microwave processing in a 60 kW system, and this issue should be evaluated in future research for PFSP puree to find success as a functional food ingredient in various food systems. This is the 1st study of PFSP puree being treated by a continuous flow 60 kW microwave system followed by aseptic packaging.

Acknowledgment

The authors would like to thank Jack Canady and Karl Hedrick III for pilot plant technical support.

References

- Ancos B, Cano MP, Hernandez A, Monreal M. 1999. Effects of microwave heating on pigment composition and colour of fruit purees. *J Sci Food Agric* 79:663–70.
- AOAC Intl. 2006. Official method - 934.01: loss on drying (moisture) at 95 to 100°C for feeds, Official method - 966.23: microbiological methods. In: Cunniff P, editor. Official methods of analysis of AOAC Int. 18th ed. Arlington, Va.: AOAC Int.
- Bertelli D, Plessi M, Miglietta F. 2004. Effect of industrial microwave treatment on the antioxidant activity of herbs and spices. *Ital J Food Sci* 16(1):97–103.
- Brand-Williams W, Cuvelier M, Berset C. 1995. Use of a free radical method to evaluate antioxidant activity. *Lebensm-Wiss U-Technol* 28:25–30.
- Brinley TA, Stam CN, Truong V-D, Coronel P, Kumar P, Simunovic J, Sandeep KP, Cartwright GD, Swartzel KR, Jaykus L-A. 2007. Feasibility of utilizing bio-indicators for testing microbial inactivation in sweetpotato purees processed with a continuous flow microwave system. *J Food Sci* 72(5):E235–42.
- Cevallos-Casals B, Cisneros-Zevallos L. 2003. Stoichiometric and kinetic studies of phenolic antioxidants from Andean purple corn and red-fleshed sweetpotato. *J Agric Food Chem* 51:3313–9.
- Chang C, Lin H, Chang C, Liu Y. 2006. Comparisons on the antioxidant properties of fresh, freeze-dried and hot-air-dried tomatoes. *J Food Eng* 77:478–5.
- Coronel P, Simunovic J, Sandeep KP. 2003. Thermal profile of milk after heating in a continuous microwave unit. *J Food Sci* 68:1976–81.
- Coronel P, Truong V-D, Simunovic J, Sandeep KP, Cartwright GD. 2005. Aseptic processing of sweetpotato purees using a continuous flow microwave system. *J Food Sci* 70(9):E531–6.
- Datta A, Barringer S, Morgan M. 1997. Effect of composition and temperature on dielectric properties of foods at 2,450 MHz and 27 MHz. In: Proceedings of the Conference on food engineering of the American institute of chemical engineers November 22–26: Los Angeles, Calif. p 14–20.
- Datta AK. 2000. Thermal sterilization of canned liquid foods. In: Frederick FJ, editor. Wiley encyclopedia of food science and technology, 2nd ed. New York: Wiley. p 2321–2.
- Downes FP, Ito K. 2001. Compendium of methods for the microbiological examination of foods (CMMEF). 4th ed. Washington D.C.: American Public Health Assn. 676 p.
- Drozd JM, Joines WT, inventors; Industrial Microwave Systems, Inc., assignee. 2001 Jul 24. Electromagnetic exposure chamber with a focal region. U.S. patent 6,265,702.
- Fasina OO, Walter WM, Fleming HP, Simunovic N. 2003. Viscoelastic properties of restructured sweetpotato puree. *Int J Food Sci Technol* 38:421–5.
- Herve AG, Tang J, Luedecke L, Feng H. 1998. Dielectric properties of cottage cheese and surface treatment using microwaves. *J Food Eng* 37:389–410.
- Giusti M, Wrolstad R. 2001. Characterization and measurement of anthocyanins by UV-visible spectroscopy. In: Wrolstad R, Schwartz S, editors. Current protocols in food analytical chemistry. New York: John Wiley & Sons, Inc. p F1.2.1–13.
- Kano M, Takayanagi T, Harada K, Mikano K, Ishikawa F. 2005. Antioxidative activity of anthocyanins from purple sweet potato, *Ipomea batatas*, cultivar Ayamurasaki. *Biosci Biotech Biochem* 69(5):979–88.
- Kays S. 1985. Formulated sweet potato products. In: Bouwkamp J, editor. Sweet potato products: a natural resource for the tropics. Boca Raton, Fla.: CRC Press. p 205–19.
- Klopotek Y, Otto K, Bohm V. 2005. Processing strawberries to different products alters contents of vitamin C, total phenolics, total anthocyanins, and antioxidant capacity. *J Agric Food Chem* 53:5640–6.
- Kumar P, Coronel P, Simunovic J, Truong V-D, Sandeep KP. 2007. Measurement of dielectric properties of pumpable food materials under static and continuous flow conditions. *J Food Sci* 72(4):E177–83.
- [NFPA] Natl. Food Processors Assn. 1996. Potatoes, sweet and solid pack. In: Thermal processes for low-acid foods in metal containers, Bulletin 26-L, 13th edition, NFPA.
- Oki T, Masuda M, Furuta S, Nishiba Y, Terahara N, Suda I. 2002. Involvement of anthocyanins and other phenolic compounds in radical-scavenging activity of purple-fleshed sweet potato cultivars. *J Food Sci* 67(5):1752–6.
- Oki T, Osame M, Masuda M, Kobayashi M, Furuta S, Nishiba Y, Kumagai T, Sato T, Suda I. 2003. Simple and rapid spectrophotometric method for selecting purple-fleshed sweet potato cultivars with a high radical-scavenging activity. *Breed Sci* 53:101–7.
- Philpott P, Gould K, Markham K, Lewthwaite L, Ferguson L. 2003. Enhanced coloration reveals high antioxidant potential in new sweetpotato cultivars. *J Sci Food Agric* 83:1076–82.
- Prior R, Hoang H, Gu L, Wu X, Bacchiocca M, Howard L, Hampsch-Woodill M, Huang D, Ou B, Jacob R. 2003. Assays for hydrophilic and lipophilic antioxidant capacity (oxygen radical absorbance capacity (ORAC_{FL})) of plasma and other biological food samples. *J Agric Food Chem* 51:3273–9.
- Randhir R, Shetty K. 2004. Microwave-induced stimulation of L-DOPA, phenolics, and antioxidant activity in fava bean (*Vicia faba*) for Parkinson's diet. *Process Biochem* 39:1775–84.
- Rodriguez-Saona L, Giusti M, Wrolstad R. 1998. Anthocyanin pigment composition of red-fleshed potatoes. *J Food Sci* 63:457–65.
- Schmidt B, Erdman J, Lila M. 2005. Effects of food processing on blueberry antiproliferation and antioxidant activity. *J Food Sci* 70(6):S389–94.
- Singh R, Heldman D. 2001. Introduction to food engineering. Amsterdam: Academic Press. 659 p.
- Singleton V, Orthofer R, Lamuela-Raventos R. 1999. Analysis of total phenol and other oxidation substrates and antioxidants by means of Folin-Ciocalteu reagent. *Methods Enzymol* 299:152–78.
- Steed LE, Truong V-D. 2008. Anthocyanin content, antioxidant activity and selected physical properties of flowable purple-fleshed sweetpotato purees. *J Food Sci* 73(5):S216–21.
- Steffe J. 1996. Rheological methods in food processing engineering, 2nd ed. East Lansing, Mich.: Freeman Press. 418 p.
- Suda I, Oki T, Masuda M, Kobayashi M, Nishiba Y, Furuta S. 2003. Review: physiological functionality of purple-fleshed sweetpotato containing anthocyanins and their utilization in foods. *JARQ* 37(3):167–73.
- Sumnu G, Sahin S. 2005. Recent developments in microwave heating. In: Sun D, editor. Emerging technologies for food processing. San Diego, Calif.: Elsevier Academic Press. p 419–44.
- Teow CC, Truong V-D, McFeeters RF, Thompson RL, Pecota KV, Yencho GC. 2007. Antioxidant activities, phenolic and β -carotene contents of sweet potato genotypes with varying flesh colours. *Food Chem* 103:829–38.
- Terahara N, Konczak I, Ono H, Yoshimoto M, Yamakawa O. 2004. Characterization of acylated anthocyanins in callus induced from storage root of purple-fleshed sweet potato, *Ipomea batatas* L. *J of Biomed and Biotech* 5:279–86.
- Truong V-D, McFeeters R, Thompson R, Dean L, Shofran B. 2007. Phenolic acid content and composition in leaves and roots of common commercial sweetpotato (*Ipomea batatas* L.) cultivars in the United States. *J Food Sci* 72:C343–9.
- Wang Y, Wig TD, Tang J, Hallberg LM. 2003. Dielectric properties of RF and microwave pasteurization and sterilization. *J Food Eng* 57:257–68.
- Wu X, Beecher G, Holden J, Haytowitz D, Gebhardt S, Prior R. 2004. Lipophilic and hydrophilic antioxidant capacities of common foods in the United States. *J Agric Food Chem* 52:4026–37.
- Wu X, Beecher G, Holden J, Haytowitz D, Gebhardt SA. 2006. Concentrations of anthocyanins in common foods in the United States and estimation of normal consumption. *J Agric Food Chem* 54(11):4069–75.
- Yoshimoto M, Okuno S, Yoshinaga M, Yamakawa O, Yamaguchi M, Yamada J. 1999. Antimutagenicity of sweetpotato (*Ipomea batatas*) roots. *Biosci Biotechnol Biochem* 63(3):536–41.