

GROUNDWATER AND WELLS



Thomas Harter



Kearney Agricultural Center &
University of California, Davis

ThHarter@ucdavis.edu *http://groundwater.ucdavis.edu*

© Thomas Harter, University of California, Davis, 2004

1

Workshop Outline



© Thomas Harter, University of California, Davis, 2004

2

What is Groundwater?

- An underground lake?
- A network of underground rivers?
- A rectangular network of pipelike water arteries?
- A giant sponge?

© Thomas Harter, University of California, Davis, 2004

3

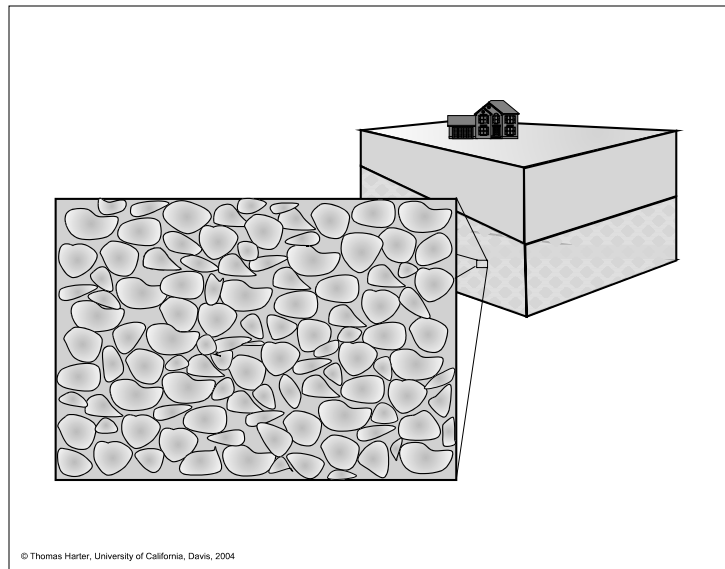

4

Groundwater in Different Sediments and Rocks

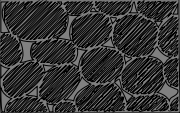

well-sorted sediment

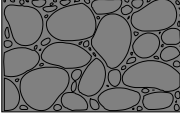

poorly sorted sediment

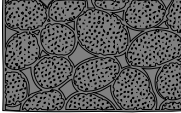

porous sediment

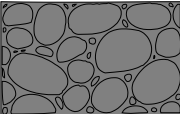

consolidated sediment

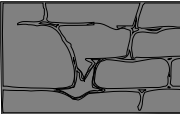

dissolution of rock

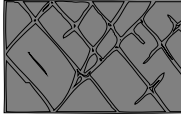

rock fractures

© Thomas Harter, University of California, Davis, 2004

5

general type	origin	material	name
unconsolidated	glaciers	sand, silt, clay	till, outwash
	water: rivers, lakes, ocean deposits	gravel, sand, silt, clay, organic matter	alluvial sediments, fluvial sediments, marine sediments
	wind	silt, sand	loess, sand dunes
consolidated	lithified sediments	sand silt clay	sandstone, siltstone, shale, conglomerate,
	chemical sediments	gravel, sand, silt calcium carbonate calcium sulfate	limestone, dolomite gypsum
	igneous rocks		granite basalt
	metamorphic rocks	sandstone shale limestone granite	quartzite slate marble gneiss

6

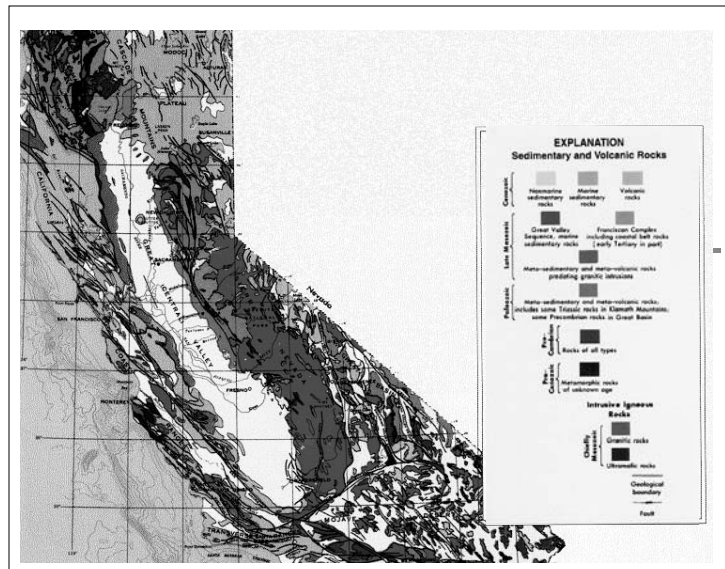

7

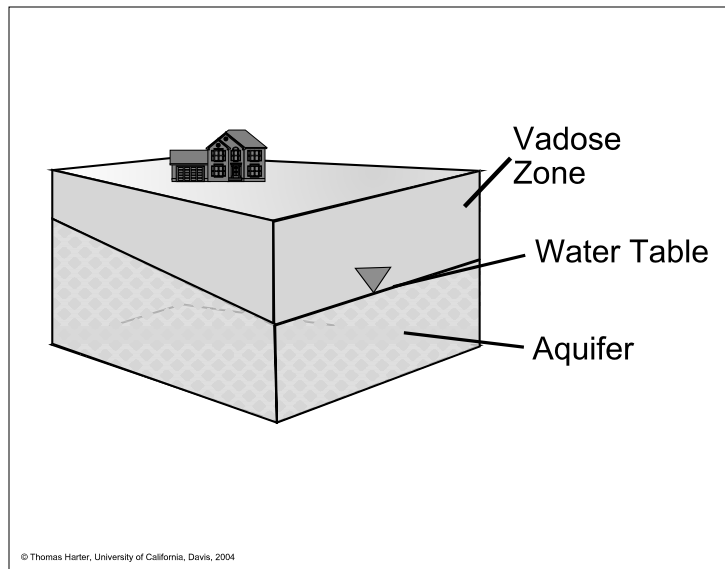

8

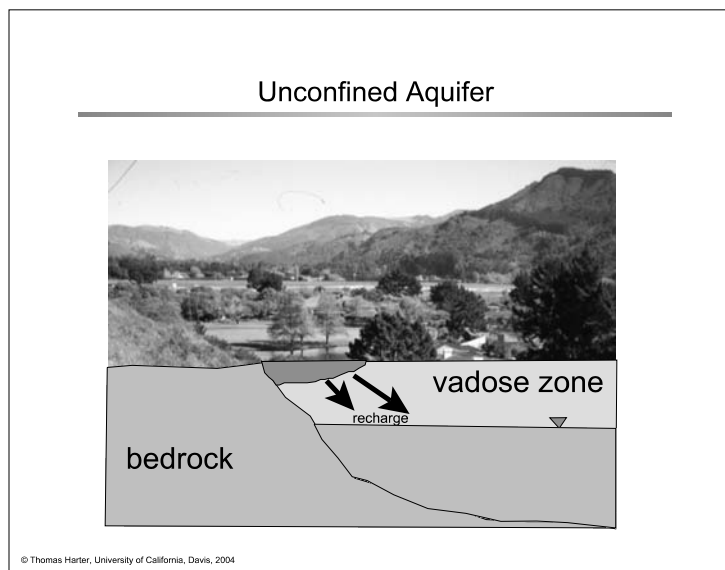

9

Confined (or: Artesian) Aquifer

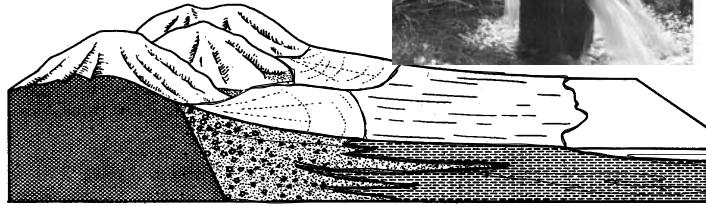

Confined aquifers created by deposition of alternating layers of permeable sand and gravel and impermeable silts and clays deposited in intermontane basins.

adopted from: Fetter, 1988

10

Semi-Confined Aquifer

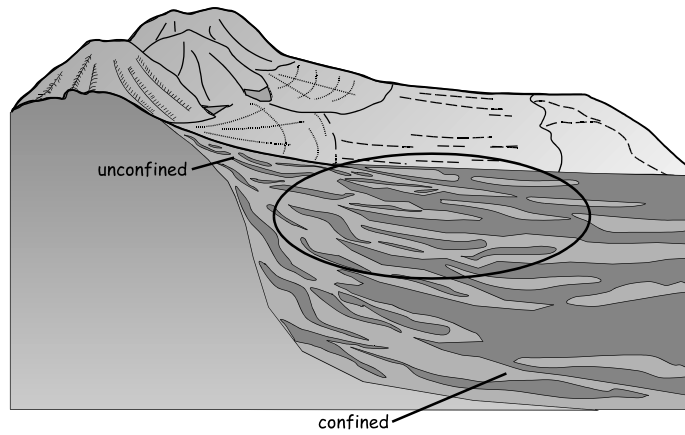

© Thomas Harter, University of California, Davis, 2004

11

Perched Water Table

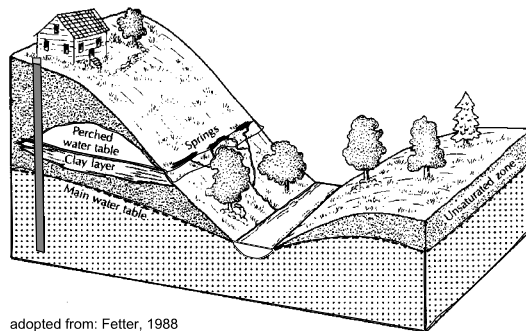

adopted from: Fetter, 1988

© Thomas Harter, University of California, Davis, 2004

12

How much groundwater is in an aquifer?

As much as there is pore space?

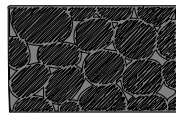

well-sorted sediment

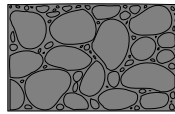

poorly sorted sediment

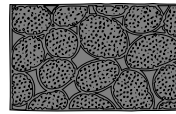

porous sediment

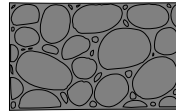

consolidated sediment

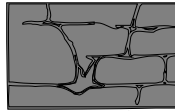

dissolution of rock

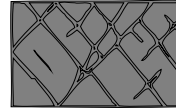

rock fractures

© Thomas Harter, University of California, Davis, 2004

13

Porosity and Specific Yield of Selected Materials in %

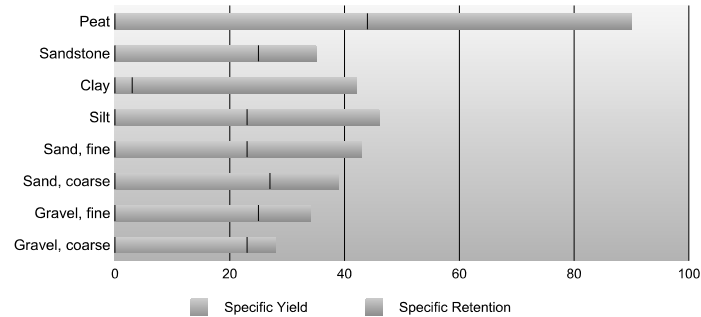

© Thomas Harter, University of California, Davis, 2004

14

In which direction and how fast does groundwater flow?

Same principle as a ball on a hill ...

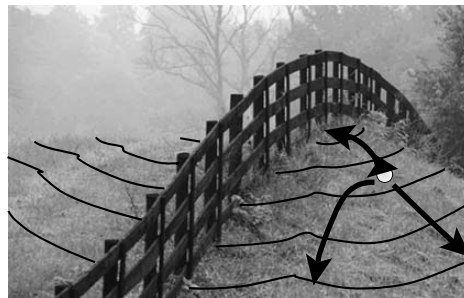

© Thomas Harter, University of California, Davis, 2004

15

Downslope across the contours!



© Thomas Harter, University of California, Davis, 2004

16

Beware: not quite like a ball -

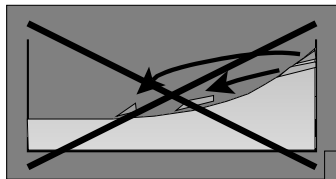

more like water in a tub

cross-section of a tub

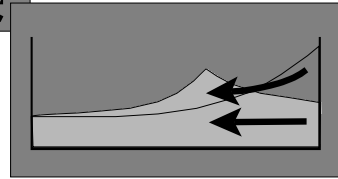

© Thomas Harter, University of California, Davis, 2004

17

cross-section between two lakes / canals

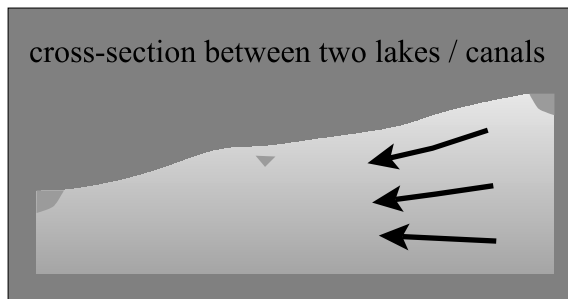

© Thomas Harter, University of California, Davis, 2004

18

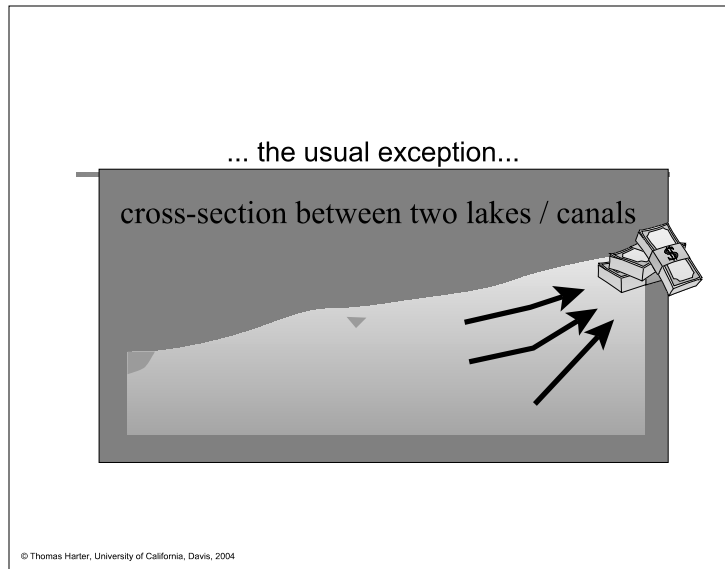

19

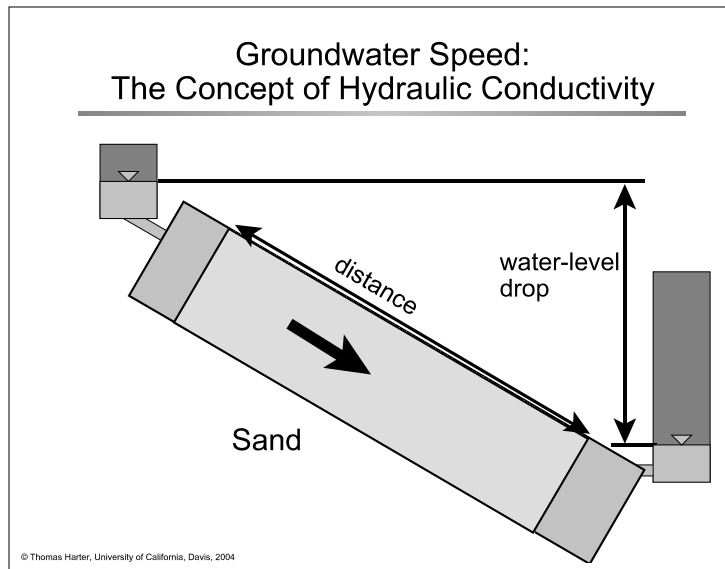

20

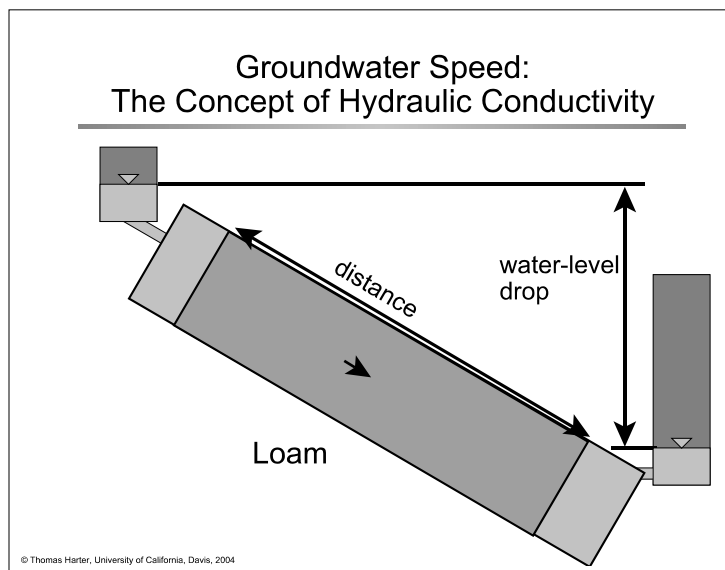

21

Groundwater Speed: The Concept of Hydraulic Gradient

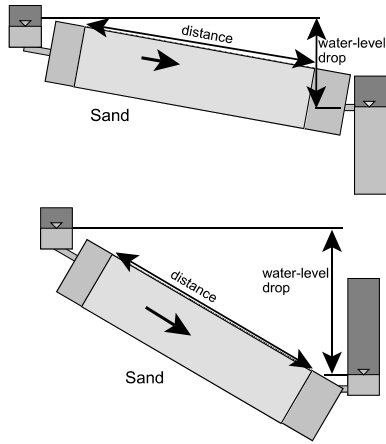

© Thomas Harter, University of California, Davis, 2004

22

Cone of Depression

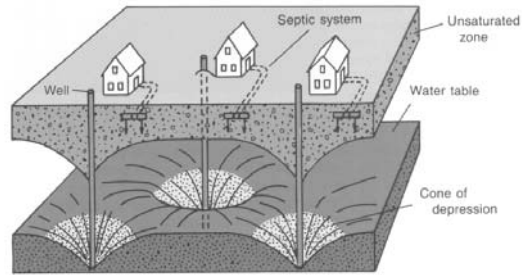

Effect of concentrated housing on ground-water level.

from: U.S. Geological Survey, 'Ground Water and the Rural Homeowner'

© Thomas Harter, University of California, Davis, 2004

23

Influence of Transmissivity on Cone of Depression

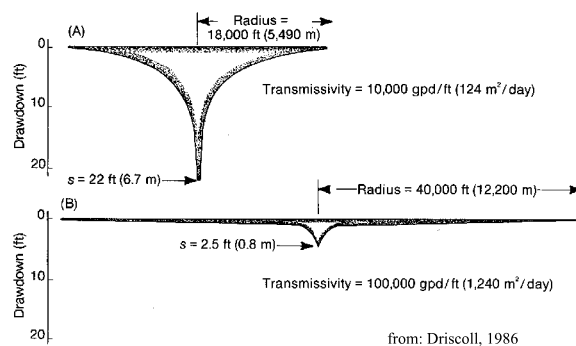

from: Driscoll, 1986

© Thomas Harter, University of California, Davis, 2004

24

Specific Capacity of a Well

Specific capacity of a well =
amount of pumpage per foot of drawdown.
(measured as gpm/ft)

- ▶ very low: 1 gpm/ft; very high: 100 gpm/ft
- ▶ approximately proportional to hydraulic conductivity
- ▶ decreases with time during pumping test
- ▶ decreases with increased pumping rate
- ▶ decreases with lower water level in a well
- ▶ larger in a properly designed and developed well
- ▶ affected by land subsidence

© Thomas Harter, University of California, Davis, 2004

25

What is the practical meaning of hydraulic conductivity and transmissivity?

- ▶ An aquifer with double the conductivity will yield double as much water at the well.
- ▶ A confined aquifer with double the thickness will yield double as much water at the well.
- ▶ At the same pumping rate, well drawdown in a confined aquifer will be half as much at double the hydraulic conductivity (**specific capacity of well is doubled**).
- ▶ Water will flow double as fast from a leaking river or canal, if the hydraulic conductivity below the river / canal and in the aquifer is double as large.

© Thomas Harter, University of California, Davis, 2004

26

Where does groundwater come from and where does it eventually go?

- The Hydrologic Cycle -

© Thomas Harter, University of California, Davis, 2004

27

Groundwater in California's Valleys

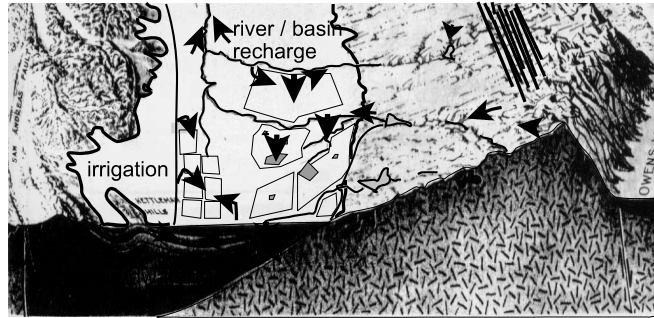

© Thomas Harter, University of California, Davis, 2004

28

Water Well Construction

The major steps in installing a good well

- ▶ Well Location and Design
- ▶ Well Drilling
- ▶ Well Installation
- ▶ Well Development
- ▶ Pump Installation
- ▶ Well Water Quality Protection
- ▶ Collection and Analysis of Pumping Test Data

© Thomas Harter, University of California, Davis, 2004

29

How do we find out where to drill a well?

Groundwater Exploration Techniques

- ▶ Well driller's experience

© Thomas Harter, University of California, Davis, 2004

30

How do we find out where to drill a well?

Groundwater Exploration Techniques

- ▶ Well driller's experience
- ▶ **Topographic maps**

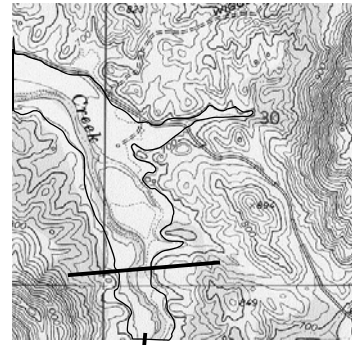
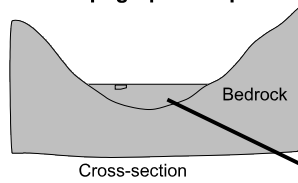

Valley floor (=> the "bathtub")

© Thomas Harter, University of California, Davis, 2004

31

How do we find out where to drill a well?

Groundwater Exploration Techniques

- ▶ Well driller's experience
- ▶ Topographic maps
- ▶ **Geologic, hydrogeologic, hydrogeochemical maps**

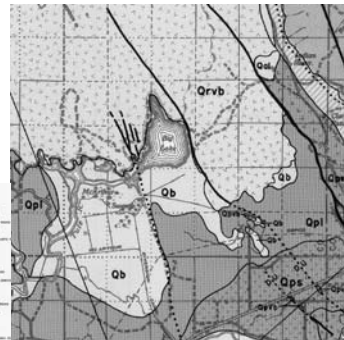

from: CaDWR Bulletin 98

© Thomas Harter, University of California, Davis, 2004

32

How do we find out where to drill a well?

Groundwater Exploration Techniques

- ▶ Well driller's experience
- ▶ Topographic maps
- ▶ **Depth to groundwater**

<10'
50'
>100'
>200'
>400'



from: CaDWR, 1992

© Thomas Harter, University of California, Davis, 2004

33

How do we find out where to drill a well?

Groundwater Exploration Techniques

- ▶ Well driller's experience
- ▶ Topographic maps
- ▶ Geologic, hydrogeologic, hydrogeochemical maps
- ▶ **Aerial photographs, satellite images**
 - Vegetation types



© Thomas Harter, University of California, Davis, 2004

34

How do we find out where to drill a well?

Groundwater Exploration Techniques

- ▶ Well driller's experience
- ▶ Topographic maps
- ▶ Geologic, hydrogeologic, hydrogeochemical maps
- ▶ Aerial photographs, satellite images
 - Vegetation types
 - Landforms
 - Drainage patterns
 - Fracture traces and lineaments**

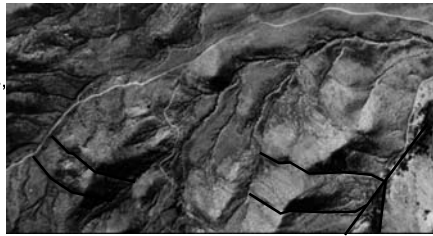

© Thomas Harter, University of California, Davis, 2004

35

Other Well Location Criteria

- ▶ Accessibility for drilling and service equipment
- ▶ Distance / elevation gain to end use
- ▶ Existing groundwater contamination

© Thomas Harter, University of California, Davis, 2004

36

Other Well Location Criteria

- Potential groundwater contamination
 - Unfavorable topography, e.g. low spot
 - Storage areas of chemicals
 - Gasoline and other underground storage tanks
 - Nearby streams
 - Septic tanks (not an issue for irrigation wells)
- ===> well should be sufficiently upgradient ("uphill") from potential sources
- Location of nearby wells
- Local ordinances and state regulations

© Thomas Harter, University of California, Davis, 2004

37

Water Well: Principal Components

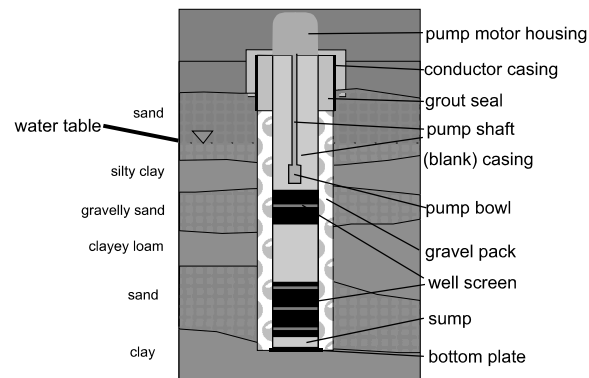

© Thomas Harter, University of California, Davis, 2004

38

Water Well with Continuous Screen

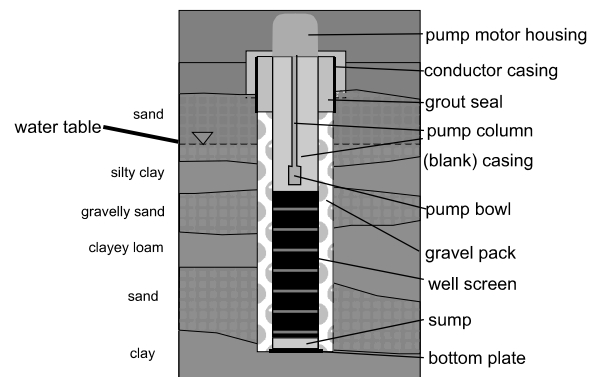

© Thomas Harter, University of California, Davis, 2004

39

Water Well with Natural Pack

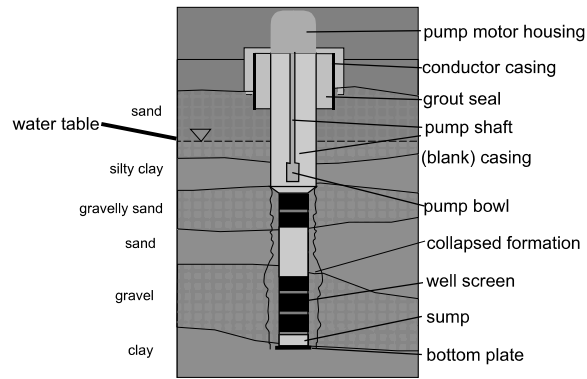

© Thomas Harter, University of California, Davis, 2004

40

Open Bottom Well in Unconsolidated Material

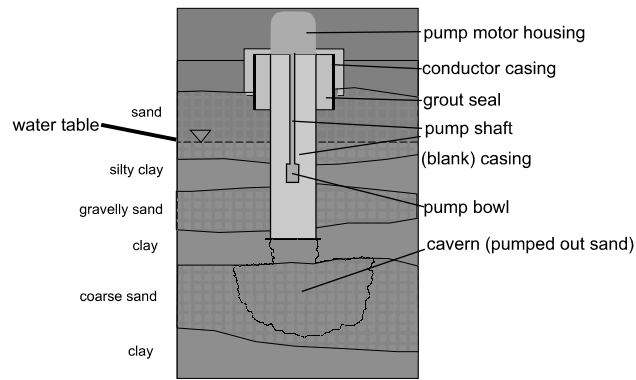

© Thomas Harter, University of California, Davis, 2004

41

Water Well in Hard Rock

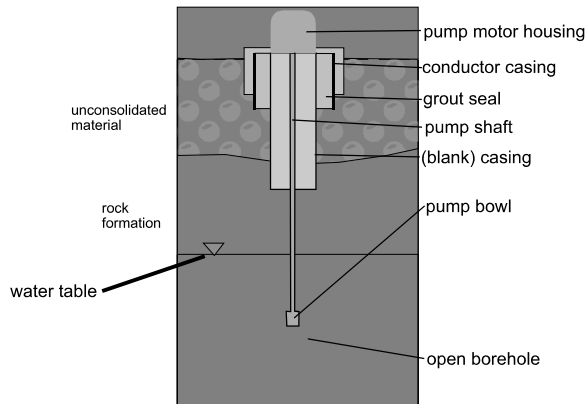

© Thomas Harter, University of California, Davis, 2004

42

Well Drilling Techniques

- Hand-dug wells
- Auger drilling
- Cable tool drilling
- Rotary drilling
- Reverse rotary drilling
- Air drilling
- Driven wells

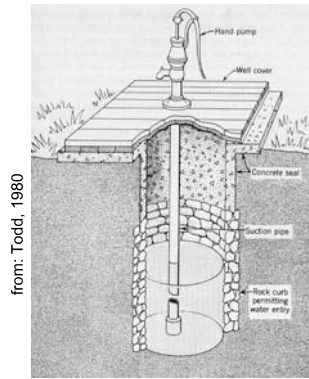

from: Todd, 1980

© Thomas Harter, University of California, Davis, 2004

Well Drilling Techniques

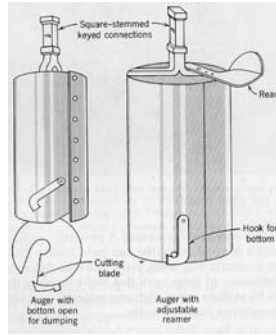

Bucket auger
(from: Todd, 1980)

Solid stem auger
(from: Driscoll, 1986)



- Hand-dug wells
- Auger drilling
- Cable tool drilling
- Rotary drilling
- Reverse rotary drilling
- Air drilling
- Driven wells

© Thomas Harter, University of California, Davis, 2004

Well Drilling Techniques

- Hand-dug wells
- Auger drilling
- Cable tool drilling
- Rotary drilling
- Reverse rotary drilling
- Air drilling
- Driven wells

TOOLS OF THE TRADE:

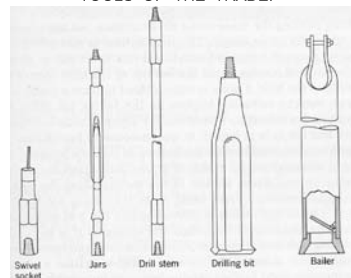

from: Todd, 1980

© Thomas Harter, University of California, Davis, 2004



© Thomas Harter, University of California, Davis, 2004

46

Cable-Tool Rig

► Advantages:

- Useable in almost all types of formation
- Very practical in unconsolidated material with rocks and boulders
- Inexpensive drilling rig, small crew (1-2)
- Low equipment maintenance
- Stabilized borehole during drilling
- Reliable formation and water samples can be collected from any depth
- Rigs can go into rugged terrain
- Little make-up water required
- No additives required
- No lost circulation
- Estimates of yield at any depth from bailing

© Thomas Harter, University of California, Davis, 2004

47

Cable-Tool Rig

► Disadvantages

- Slow penetration rate
- Penetration rate depends on borehole diameter
- Higher casing cost (heavier wall)
- Difficulties with pulling back (to expose screen) in some formations
- (Need for telescoping well for depths beyond 700 ft)

© Thomas Harter, University of California, Davis, 2004

48

Well Drilling Techniques

- Hand-dug wells
- Auger drilling
- Cable tool drilling
- Rotary drilling
- Reverse rotary drilling
- Air drilling
- Driven wells

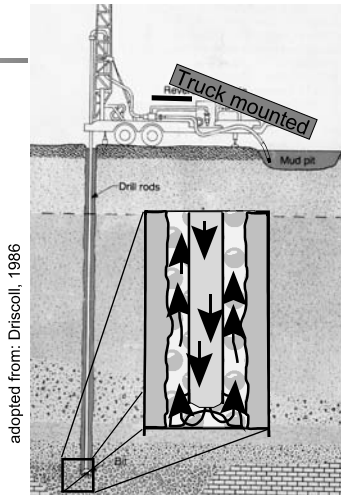

adopted from: Driscoll, 1986

© Thomas Harter, University of California, Davis, 2004

49



© Thomas Harter, University of California, Davis, 2004

50

Operation of a Rotary Drilling Rig

- Drill string assembly:
 - Drill bit (drag or cone)
 - Drill collar(s) or stabilizers
 - Drill pipe
 - Kelly (square, hexagonal, or fluted pipe)
 - Rotating motion: drive shaft => rotary table => kelly
 - Alternative: top-head drive
- Water circulation:
 - Pit
 - Mudpump
 - Hose
 - Water swivel
 - Drill pipe
 - Nozzles in drill bit

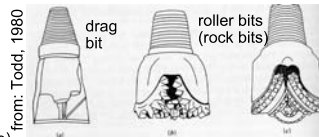

from: Todd, 1980



from: Driscoll, 1986

© Thomas Harter, University of California, Davis, 2004

51

Rotary Drilling Fluids

Purpose

- Lift cuttings from bottom of borehole to surface
- Support and stabilize borehole wall
- Seal borehole to prevent fluid loss
- Suspend cuttings when circulation is stopped
- Cool and clean the drill bit
- Lubricate bit, bearings, mud pump, and drill pipe

© Thomas Harter, University of California, Davis, 2004

52

Rotary Drilling Fluids

Additives

- Clay from native formations: muddy water
- Water with clay (bentonite) additives
- Water with polymer additives

© Thomas Harter, University of California, Davis, 2004

53

Rotary Drilling: Advantages

- High penetration rates
- Minimal casing required during drilling
- Rapid rig mobilization and demobilization
- Ease of setting well screens as part of setting casing
- Very effective for small diameter domestic and shallow wells

© Thomas Harter, University of California, Davis, 2004

54

Rotary Drilling: Disadvantages

- ▶ Larger crew than cable tool for greater depth (at least 2-3)
- ▶ Collection of accurate sample requires separate split spoon sampling / coring
- ▶ Use of drilling fluid may plug formations
- ▶ Additional knowledge and management for handling drilling fluids necessary
- ▶ Theoretical limitation: large diameter hole (>22 inches) => upward flow velocity in annulus too small (in practice, even larger diameter holes are drilled w/ rotary)
- ▶ Desanders and shale shakers required to preclude recirculation of drill cuttings, collect formation samples, and prevent plugging of sand formations w/ clay

© Thomas Harter, University of California, Davis, 2004

55

Well Drilling Techniques

- ▶ Hand-dug wells
- ▶ Auger drilling
- ▶ Cable tool drilling
- ▶ Rotary drilling
- ▶ Reverse rotary drilling
- ▶ Air drilling
- ▶ Driven wells

adopted from: Driscoll, 1986

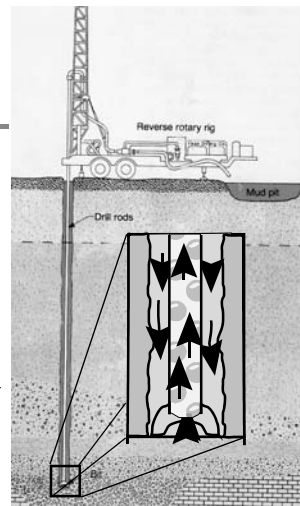

© Thomas Harter, University of California, Davis, 2004

56



Photo: Courtesy of Allan Fulton

© Thomas Harter, University of California, Davis, 2004

57

Reverse Rotary Drilling

Difference to Rotary Rigs

- ▶ Most efficient for large diameter wells in unconsolidated formation
- ▶ Also used in soft consolidated rocks (e.g., sandstone); hardrock (in conjunction with air rotary drilling)
- ▶ Similar in function to rotary, typically mounted on long-bed trailer
- ▶ Typically uses airlifting to pump drilling fluid (use of air compressor)
- ▶ In theory, native (muddy) water used as drilling fluid; in practice, organic polymers and bentonite commonly used as additives (particularly in deep wells)

© Thomas Harter, University of California, Davis, 2004

58

Reverse Rotary Drilling

Advantages

- ▶ Most advantages method for large capacity wells in unconsolidated deposits
- ▶ Porosity and permeability of formation near borehole relatively undisturbed
- ▶ Large diameter holes can be drilled quickly and economically
- ▶ Little chance for washout in borehole (low fluid velocity)
- ▶ Can minimize or eliminate addition of mud
- ▶ *see rotary drilling*

© Thomas Harter, University of California, Davis, 2004

59

Reverse Rotary Drilling

Disadvantages

- ▶ Large water supply usually needed
- ▶ Large mud pits required (3 x borehole volume)
- ▶ Some sites inaccessible due to rig size (alternative: cable-tool)
- ▶ Larger crew than for cable tool (2-4)

© Thomas Harter, University of California, Davis, 2004

60

Well Drilling Techniques

Most common method in most California hardrock areas (Sierra, Coast Range, Northeastern CA)

- Hand-dug wells
- Auger drilling
- Cable tool drilling
- Rotary drilling
- Reverse rotary drilling
- Air drilling
- Driven wells



from: Driscoll, 1986

© Thomas Harter, University of California, Davis, 2004



© Thomas Harter, University of California, Davis, 2004

Well Drilling Techniques

- Hand-dug wells
- Auger drilling
- Cable tool drilling
- Rotary drilling
- Reverse rotary drilling
- Air drilling
- Driven wells

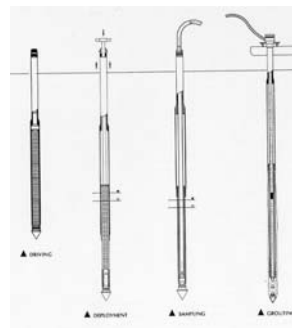

from: Geoprobe Systems Inc., 1996

© Thomas Harter, University of California, Davis, 2004

Well Logging



© Thomas Harter, University of California, Davis, 2004

64

The Electric Log or E-log

Purpose:
determine depth and thickness of permeable zones

- Spontaneous potential (Self-potential of sediments)
- + Apparent resistivity

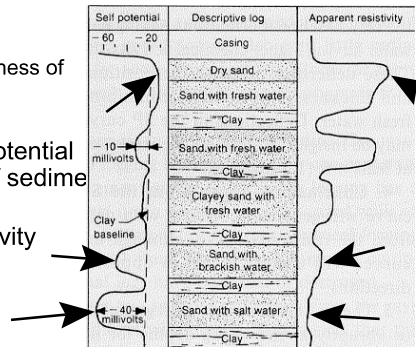

from: Driscoll, 1986

© Thomas Harter, University of California, Davis, 2004

65

Well Screen Design

► Functions:

- Access for sufficient well development
- Minimal incrusting tendency
- Low head loss
- Control sand pumping
- Optimum specific capacity

► Criteria:

- Large / sufficient percentage of open area
- Nonclogging slots
- Resistant to corrosion
- Sufficient column, tensile, and collapse strength
- Location within aquifer

© Thomas Harter, University of California, Davis, 2004

66

Screen Types

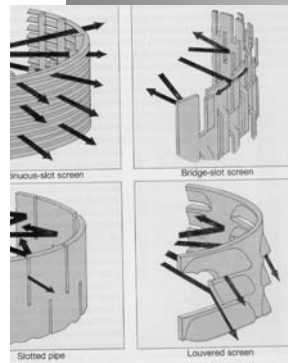

From: Roscoe Moss, 1990

- ▶ Continuous slot wire-wound screen
 - Large open area
 - Triangular shape of wire prevents sand clogging
 - High hydraulic efficiency (one condition of good spec. capacity)
- ▶ Wire-wound perforated pipe
 - High strength
 - Most expensive
- ▶ Louvred or bridge-slot
 - Limited percent open area
 - Sand clogs opening
- ▶ Slotted pipe (horizontal or vertical)
 - Several cutting methods: mill sawed (most accurate), cutting torch, casing perforator, in-place punching (least accurate)
 - Small percent open area (3% - 10%)
 - Very low hydraulic efficiency
 - Well development limited and inefficient
 - Least expensive

© Thomas Harter, University of California, Davis, 2004

67

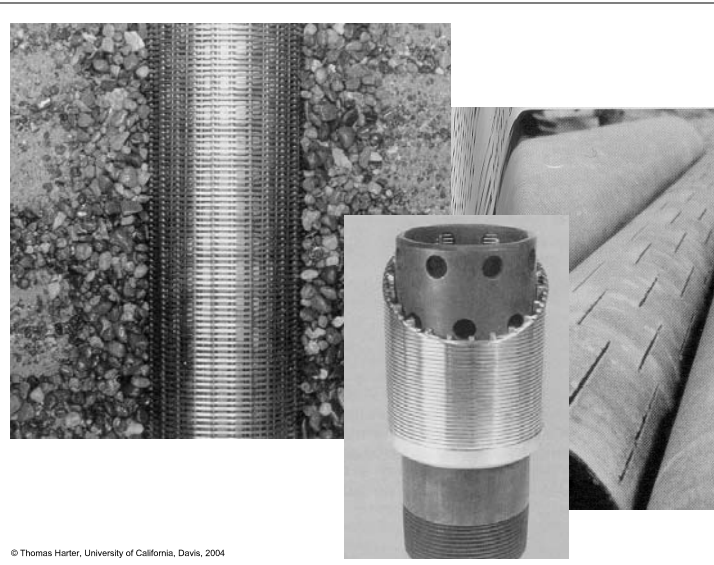

© Thomas Harter, University of California, Davis, 2004

68

Screen and Casing Materials

- ▶ Materials:
 - Metals and metal alloys; most common: steel
 - Plastics
 - Concrete
 - Others
- ▶ Available slot size: from 0.010 inch to 0.150 inch
- ▶ Use of multiple metals may lead to galvanic corrosion

© Thomas Harter, University of California, Davis, 2004

69

Criteria to Determine Slot Size and Screen Length

- % open area \approx % porosity in aquifer formation (10% - 30%)
- Maximum entry velocity < 6 ft / min.
- Slot size small enough to permit only 10% smallest particles in gravel pack (50% of aquifer formation if naturally packed)
- Screen bottom 70% - 80% of confined aquifer / if heterogeneous: permeable strata only
- Screen bottom 1/3 - 1/2 of unconfined aquifer
- Top of screen lower than anticipated drawdown

© Thomas Harter, University of California, Davis, 2004

70

Gravel Pack or Natural Pack?

- Filter packing increases effective radius of the well (higher yield, higher spec. capacity)
- In San Joaquin Valley, Salinas Valley, Southeast Desert Basins: always gravel packed
- In hardrock wells: casing landed at top of bedrock, no filter pack
- Natural pack only, where screen is set in medium to coarse sand and gravels

© Thomas Harter, University of California, Davis, 2004

71

Gravel Pack Design

- Gravel should be uniform (Uniformity coefficient = $\text{diam}_{.40\% \text{ retained}} / \text{diam}_{.90\% \text{ retained}}$ should be 2.5)
-> less separation during installation, lower head loss, improved specific capacity
- Gravel should be clean and well rounded
-> less development time, less head loss, higher yield, more effective development
- Gravel should contain more than 90% silica
-> no loss of gravel pack volume due to dissolution
- Practical thickness: 3 inches - 8 inches

© Thomas Harter, University of California, Davis, 2004

72

Well Casing

► Well Casing:

- W/ cable tool: driven; w/ rotary: lowered into larger hole
- Maintains open hole from ground surface to aquifer
- Structural support
- Isolates contaminated aquifers/aquitards from well
- Material:
 - Production well: wrought iron, alloyed and unalloyed steel
 - Monitoring well: PVC, stainless steel

► Conductor (Surface) Casing:

- Installed through upper strata only
- Support unstable material during drilling
- Reduce loss of drilling fluid
- Facilitate installation and removal of well casing
- Aid in placing sanitary seal
- Reservoir for gravel pack

© Thomas Harter, University of California, Davis, 2004

73

Well Casing Diameter

Well Yield (gpm)	Size of Pump Bowl (in.)	Optimum Size of Well Casing (in.)
< 100	4	6
75-175	5	8
150-350	6	10
300-700	8	12
500-1,000	10	14
800-1,800	12	16
1,200-3,000	14	20 *
2,000-3,800	16	24 *
3,000-6,000	20	30 *

From Driscoll, 1986

*In practice, large capacity wells are often designed w/ casing diameter = bowl size + 2"

© Thomas Harter, University of California, Davis, 2004

74

Water Well Development

Purpose

- Repair damage to formation around borehole (increase porosity and permeability reduced by shearing, clay / mud cake)
- Remove fines from gravel pack and nearby aquifer formation
- Avoid cementation/incrustation caused by abnormally high flow in limited areas around screen
- Increase specific capacity / efficiency of well
- Prevent sanding
- Obtain maximum well life

© Thomas Harter, University of California, Davis, 2004

75

Importance of Development

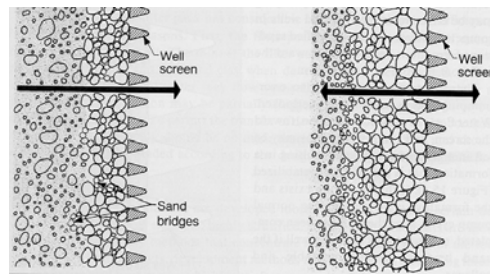

from: Driscoll, 1986

© Thomas Harter, University of California, Davis, 2004

76

Water Well Development

Implementation

- (Test) Pumping: Overpump
 - Will affect only area near top of screen
 - Causes bridging / instable gravel pack
 - Very inefficient for well development
 - Specific capacity only $\frac{1}{4}$ - $\frac{1}{2}$ of optimally developed well
 - Do not use permanent pump for development (excessive wear due to sanding)

© Thomas Harter, University of California, Davis, 2004

77

Water Well Development

Implementation

- Surging
 - Backwashing (rawhiding) with test pump
 - Mechanical surging:
 - Surge block, surge plunger, swab
 - Most common locally: double-flanged swab
 - Mechanical surging with double-flanged swab very effective
 - Short-term cost increase: \$20 - \$30 / ft. in drilling cost
 - Long-term cost savings:
 - 50% - 200% higher specific capacity => less pumping cost
 - Sand-free pumping => less maintenance, longer lifetime of well

© Thomas Harter, University of California, Davis, 2004

78

Surge & Airlifting

e.g., double-flanged swab

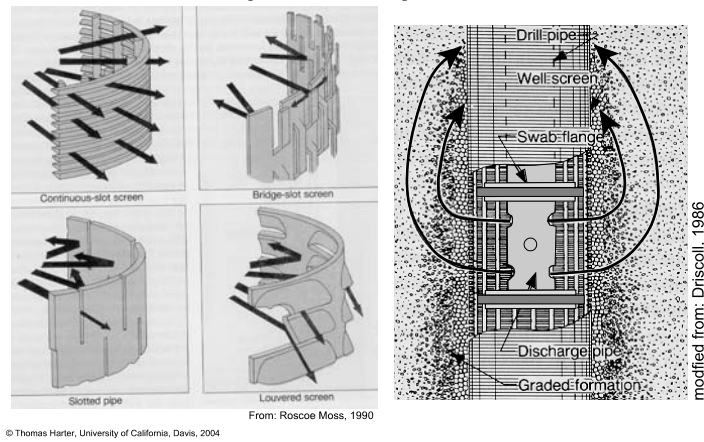

79

Water Well Development

Further Development Techniques

- Air surging
- Backwashing with air
- Hydraulic jetting (hardrock aquifers, sand and gravel aquifers)
- Hydraulic fracturing (hardrock aquifers)

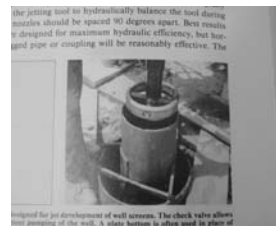

© Thomas Harter, University of California, Davis, 2004

80

Purpose of the Pumping Test

- Determine properties of the pumping well:
 - Specific capacity of the well
- Determine aquifer properties:
 - Transmissivity T
 - Storage coefficient S (confined conditions)
 - Specific yield (unconfined conditions)
 - (Aquifer boundaries and their effects)
 - (Leakage through aquitards)
 - (Aquitard storage)

© Thomas Harter, University of California, Davis, 2004

81

Water Well Design Objectives

- Highest yield with minimum drawdown = *High Well Efficiency (> 80%)*

Well Efficiency = ratio of actual specific capacity to optimal specific capacity

- Good quality water with proper protection from contamination
- Sand free water
- Long lifetime (> 25 years)
- Reasonable short-term and long-term costs

© Thomas Harter, University of California, Davis, 2004

Water Well Design Criteria

Basic Decision Tree

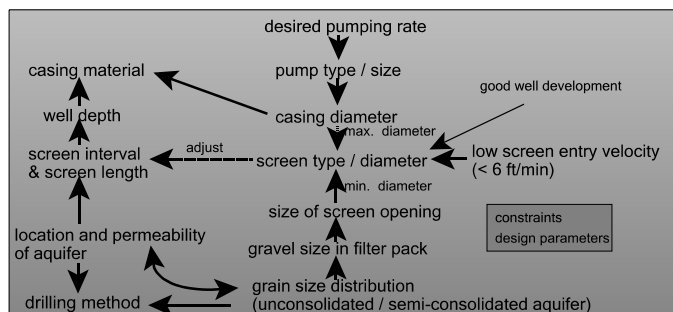

© Thomas Harter, University of California, Davis, 2004

Cost of Poor Well Design

- If the extra lift due to well losses (well inefficiency) is 60 feet, when pumping 1,000 gpm at a pump efficiency of 50%,

- Then the extra horsepower required is 30hp (22 kW)

$$hp = (1/0.5) \times 1,000 \text{ gpm} \times 60 \text{ feet} / 3,960$$

$$kW = 0.75 \text{ hp}$$

- If the well is operating for 6 months (4,300 hours)
- => additional consumption of approximately 100,000 kWh
- At \$0.10/kWh, the annual cost due to well losses is:

\$10,000.- / year

© Thomas Harter, University of California, Davis, 2004

Cost of Good Well Design

- varies with depth of well
- varies with aquifer material & location of aquifer(s)
- cost for drilling of small diameter test hole (to locate aquifer layers, to determine water quality)
- cost for high-quality, properly sized continuous-slot (wire wrap) screen (extra cost can be saved by locating it opposite productive layers only)
- cost for proper gravel pack material
- cost for proper well development

© Thomas Harter, University of California, Davis, 2004

85

Measuring Water Well Losses / Efficiency

Well Efficiency is not the same as Pump Efficiency!

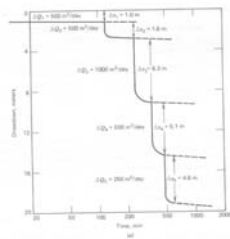

- multistep pump test w/ continuous water level monitoring
- comparison to drawdown in nearby wells (of limited value)
- pump for 1 hour: if water level recovers by 90% within 5 minutes => worst case, unacceptable well losses

© Thomas Harter, University of California, Davis, 2004

86

Well Seal and Other Components at the Wellhead

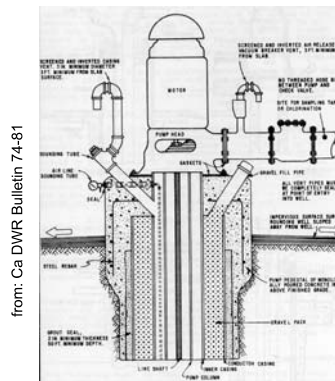

© Thomas Harter, University of California, Davis, 2004

87

Water Well Regulations

- ▶ California Well Standards:
 - Bulletin 74-81
 - Bulletin 74-90
- ▶ Includes requirements for abandoning of wells!!
- ▶ County ordinances
- ▶ All wells need to be permitted by county (permit usually obtained by driller)
- ▶ Any drilling operation requires prior notice to USA (usually done by driller)