



Liquid and Gas Fuels from Biomass

*Woody Biomass and Small Log Workshop
From Feedstock to Product*

College of the Siskiyous
19 September 2007

Bryan M. Jenkins, Professor
University of California, Davis

Bioenergy/Biofuels

Fuel	Conversion Process		
	Thermochemical	Biochemical	Physicochemical
Solids	Biomass/Chars/Charcoal	Biosolids	Biomass (incl. densified and other processed fuel)
Liquids	Methanol Biomass-to-Liquids Renewable diesels, biogasolines, other hydrocarbons and oxygenated hydrocarbons Ethanol/Mixed Alcohols Dimethyl ether (pressurized) Bio-oils (pyrolysis oils)	Ethanol Butanol Other Alcohols/ Mixed Alcohols Liquified-BioMethane (LNG) (Bio)gas-to-Liquids (GTL)	Biodiesel (esters) from Plant Oils, Yeast Oils, Algal Oils Alkanes (catalytic)
Gases	Producer gas Synthesis gas (Syngas) Hydrogen	Biogas Biomethane Compressed Biomethane (CNG) Hydrogen	

Biomass Conversion Pathways

- **Thermochemical Conversion**

- Combustion
- **Gasification**
- **Pyrolysis**

- **Bioconversion**

- **Anaerobic/Fermentation**
- **Aerobic Processing**
- **Biophotolysis**

- **Physicochemical**

- **Esters**
- **Alkanes**

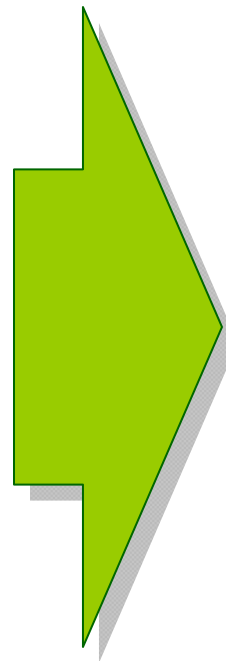

- **Energy**

- Heat
- **Electricity**

- **Fuels**

- **Solids**
- **Liquids**
- **Gases**

- **Products**

- **Chemicals**
- **Materials**

Biorefining Approaches

- **Thermochemical**

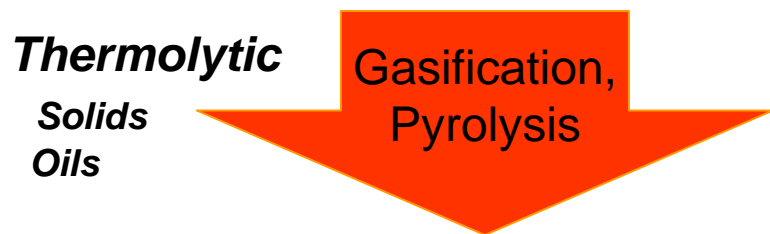

- **Synthesis gas**
 - (CO + H₂ + other)

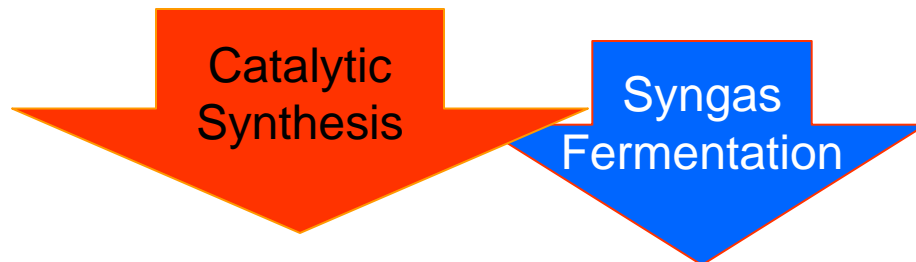

- **Hydrocarbons, hydrogen, ammonia, DME, methane, SNG, methanol, ethanol, higher alcohols, mixed alcohols...**

- **Biochemical**



- **Sugar monomers, acids**



- **Ethanol, higher alcohols, biomethane, hydrogen, acids...**

Integrated Biorefinery Concept

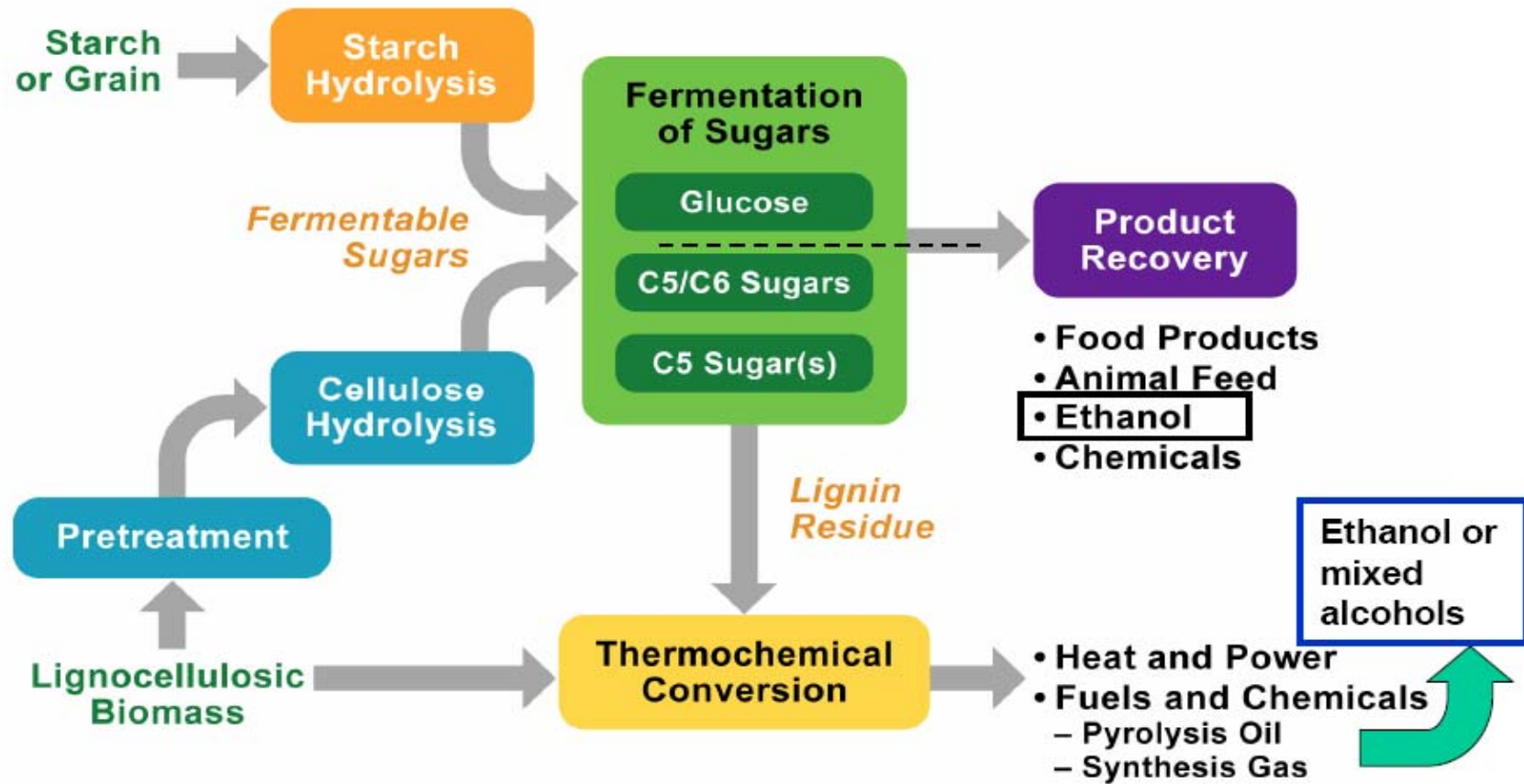

Source: US Department of Energy

Comparative Fuel Properties

Fuel	Molar Mass	Density (g/mL)	Lower Heating Value (MJ/kg)	LHV (Btu/gal-liquid)	Mass Air-Fuel Ratio (stoich)	LHV of Stoich. Mixture (MJ/kg)	Octane No.
Gasoline (l)	110	0.750	44.0	118,400	14.6	2.8	87-94
Methane (g)	16	0.00065	50.0	--	17.2	2.7	120
LNG (l)	16	0.424	49.5	75,300	~17	~2.7	~120
Methanol (l)	32	0.792	20.0	56,800	6.5	2.7	99
Ethanol (l)	46	0.785	26.9	75,800	9.0	2.7	98
Butanol (l)	74	0.810	33.0	95,900	11.2	2.7	104
Hydrogen (g)	2	0.00008	120.0	--	34.3	3.4	130+
Liquid Hydrogen (l)	2	0.070	120.0	30,100	34.3	3.4	130+
							Cetane No.
Diesel No. 2 (l)	200	0.850	42.8	130,500	14.4	2.8	40-55
Biodiesel (soyB100) (l)	292	0.880	38.3	120,900	13.8	2.6	48-60

Hydrogen: A 15 gallon automobile gasoline tank contains about 90 pounds of gasoline. For the same energy, the corresponding hydrogen tank would be 60 gallons, but the hydrogen would weigh only 34 pounds.

Transport Range for Bioenergy

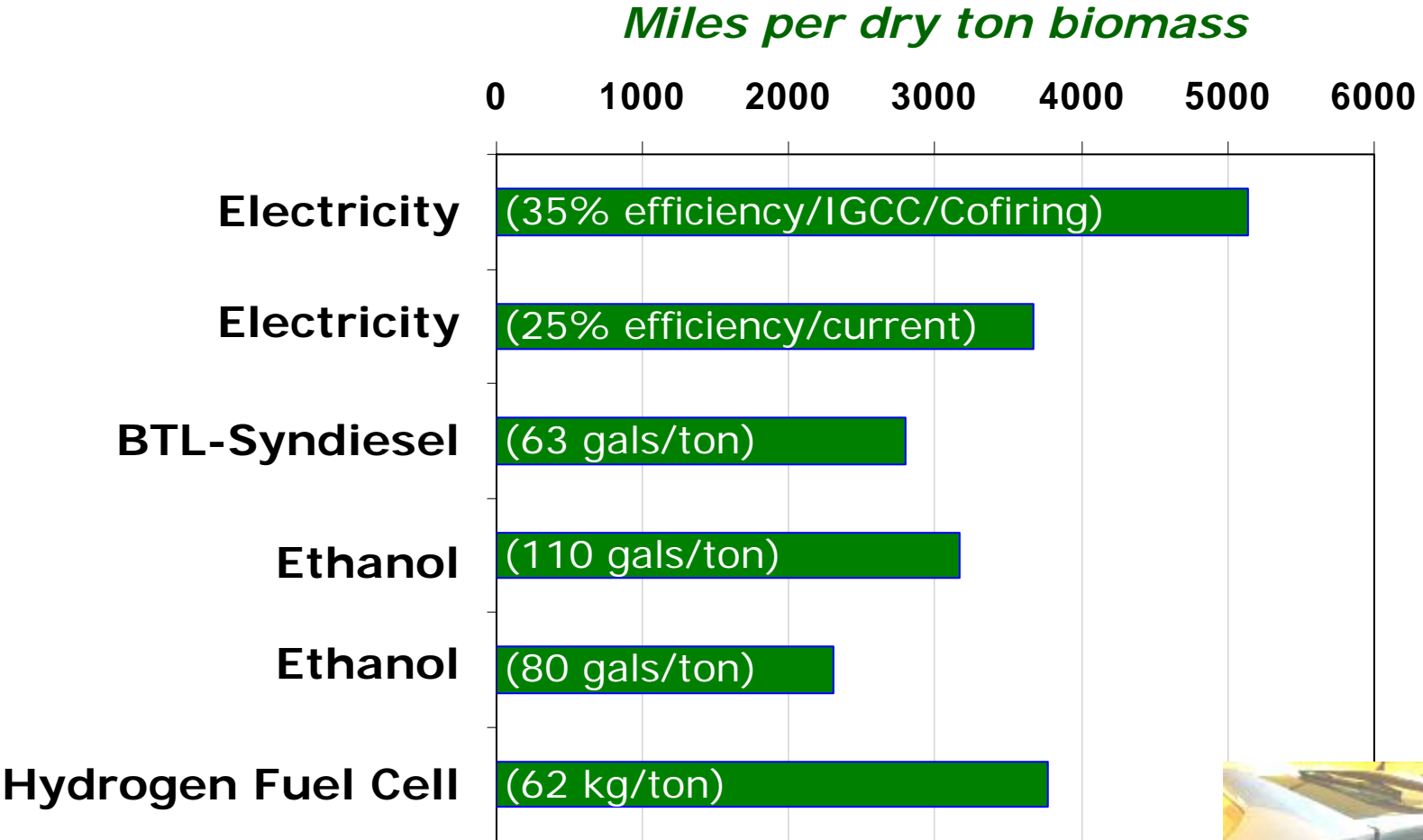

Based on hybrid vehicle with 44 miles per gallon fuel economy on gasoline, 260 Wh/mile battery (vehicle data from B. Epstein, E2). Electricity includes generating efficiency, transmission, distribution, and battery charging losses. Ethanol, BTL-Syndiesel, and H₂ include fuel distribution transport energy.



Production Scale

- Resource potential
- Biofuels potential
- Competing uses
- Co-products
- Process integration

US--Billion Ton Study

Are there sufficient resources to meet 30% of the country's petroleum requirements?

- Land resources of the U.S. *can sustainably* supply more than 1.3 billion dry tons annually and still continue to meet food, feed, and export demands
- Realizing this potential will require R&D, policy change, stakeholder involvement
- Required changes are not unreasonable given current trends

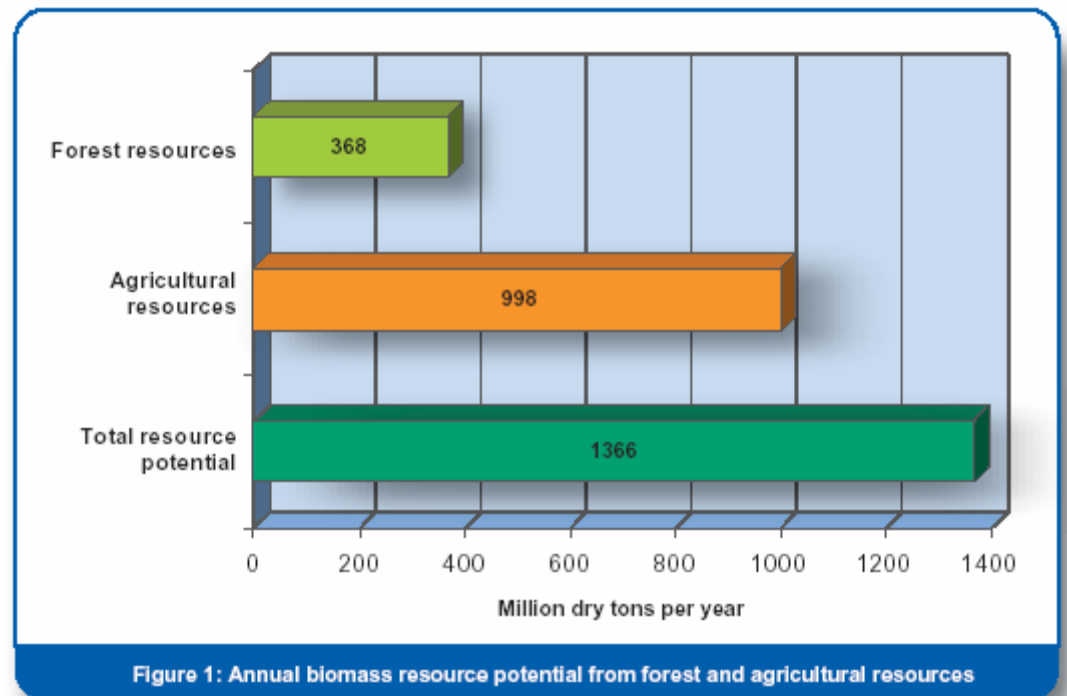

Biofuel Potential

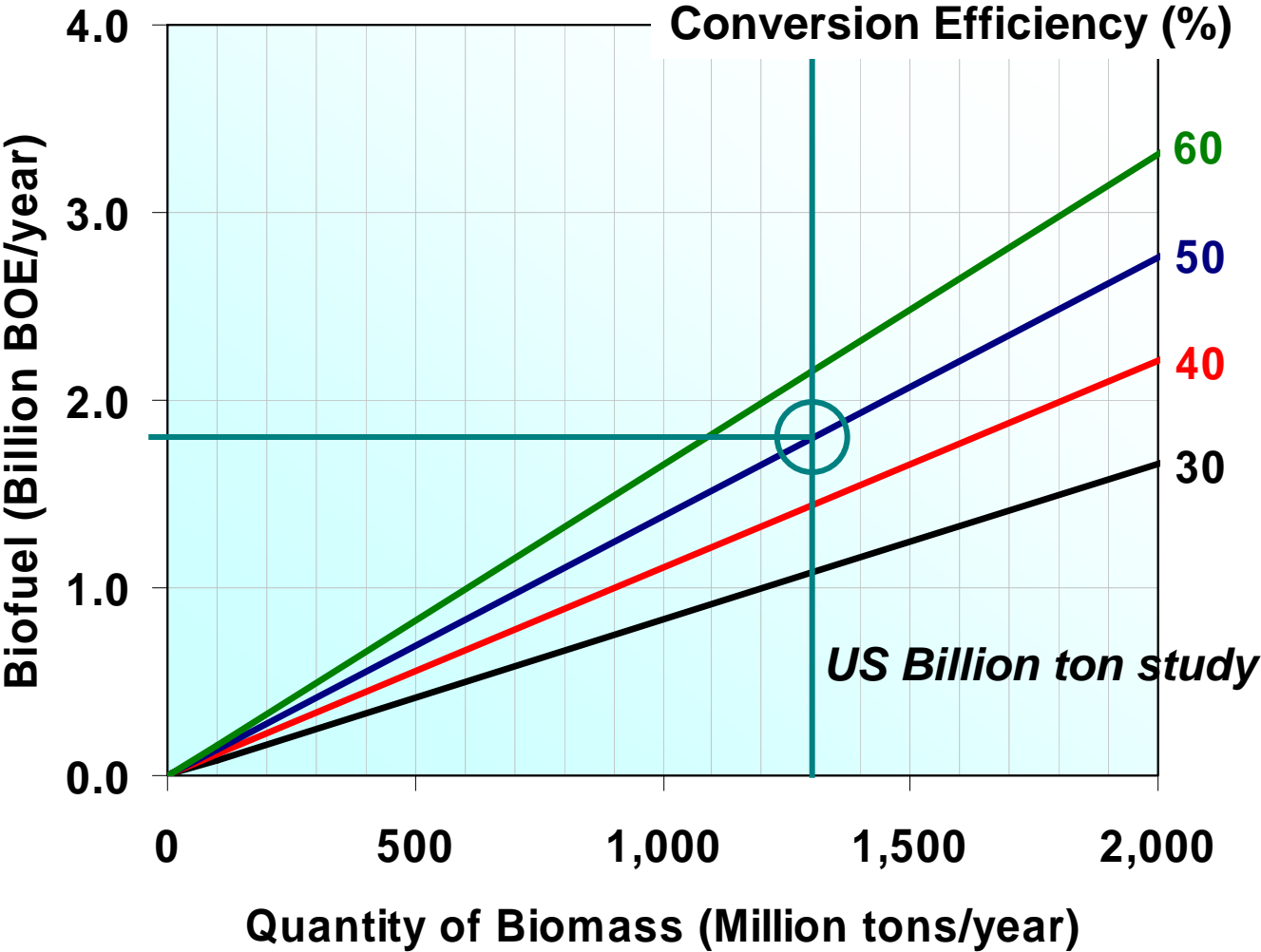

- *1.8 BBOE/year*
- *78 BGY/year diesel equivalent*
- *80-100 x 10⁹ kg/year Hydrogen equivalent*

Biofuel Potential in US Transportation

Potential of Biofuels in the U.S. Transportation Sector

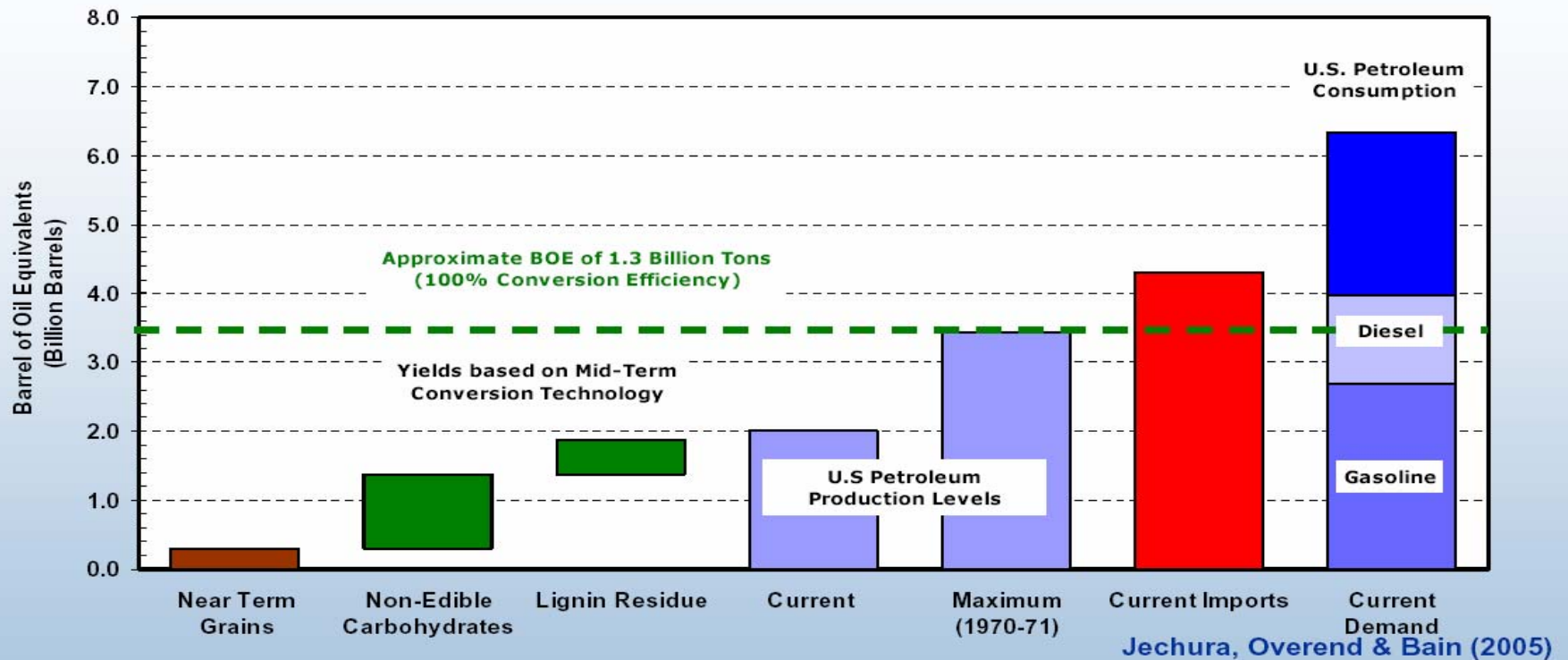



Potential bio-refinery locations

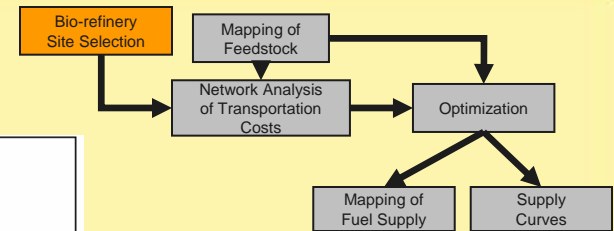

Biorefinery Network

- Potential Bio-refinery Locations
- Terminals
- Railway
- roads
- travels_npd
- Local Road
- County Road
- State Route
- Interstate Route

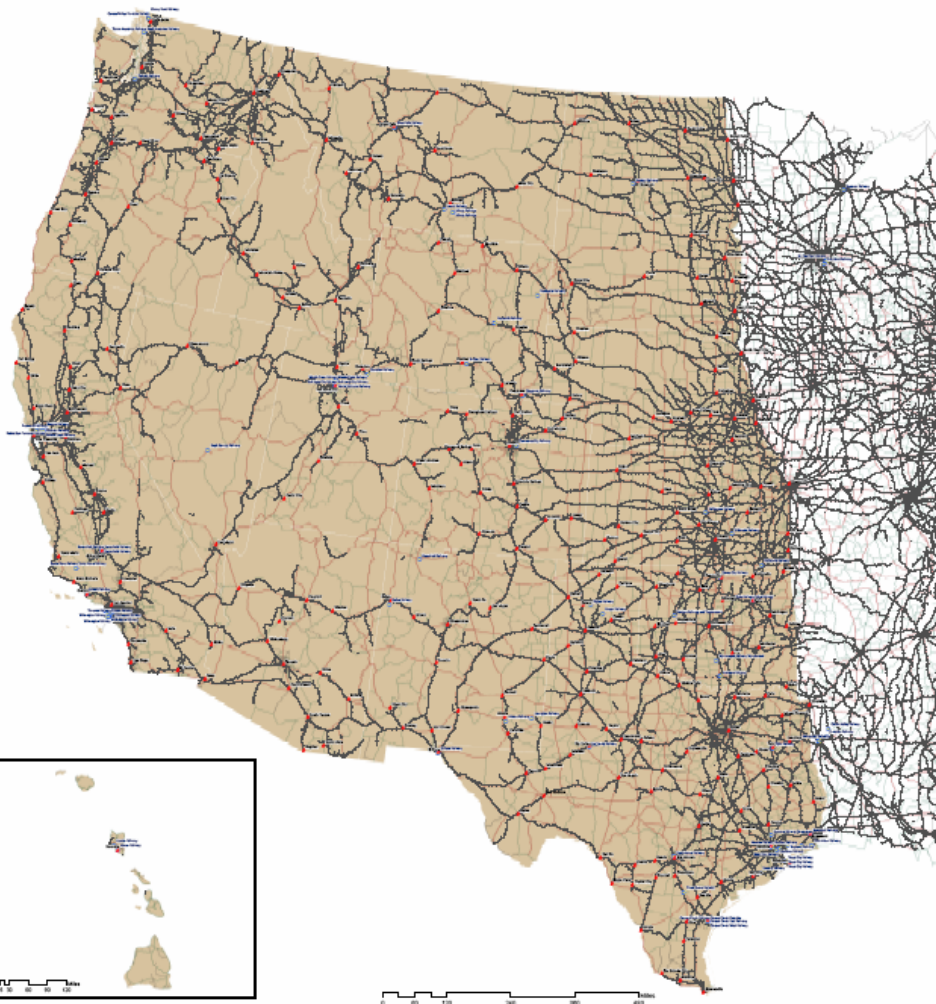

Influence of Scale Factor on Optimal Capacity

and Sensitivity of Solution

($s = \text{constant}$)

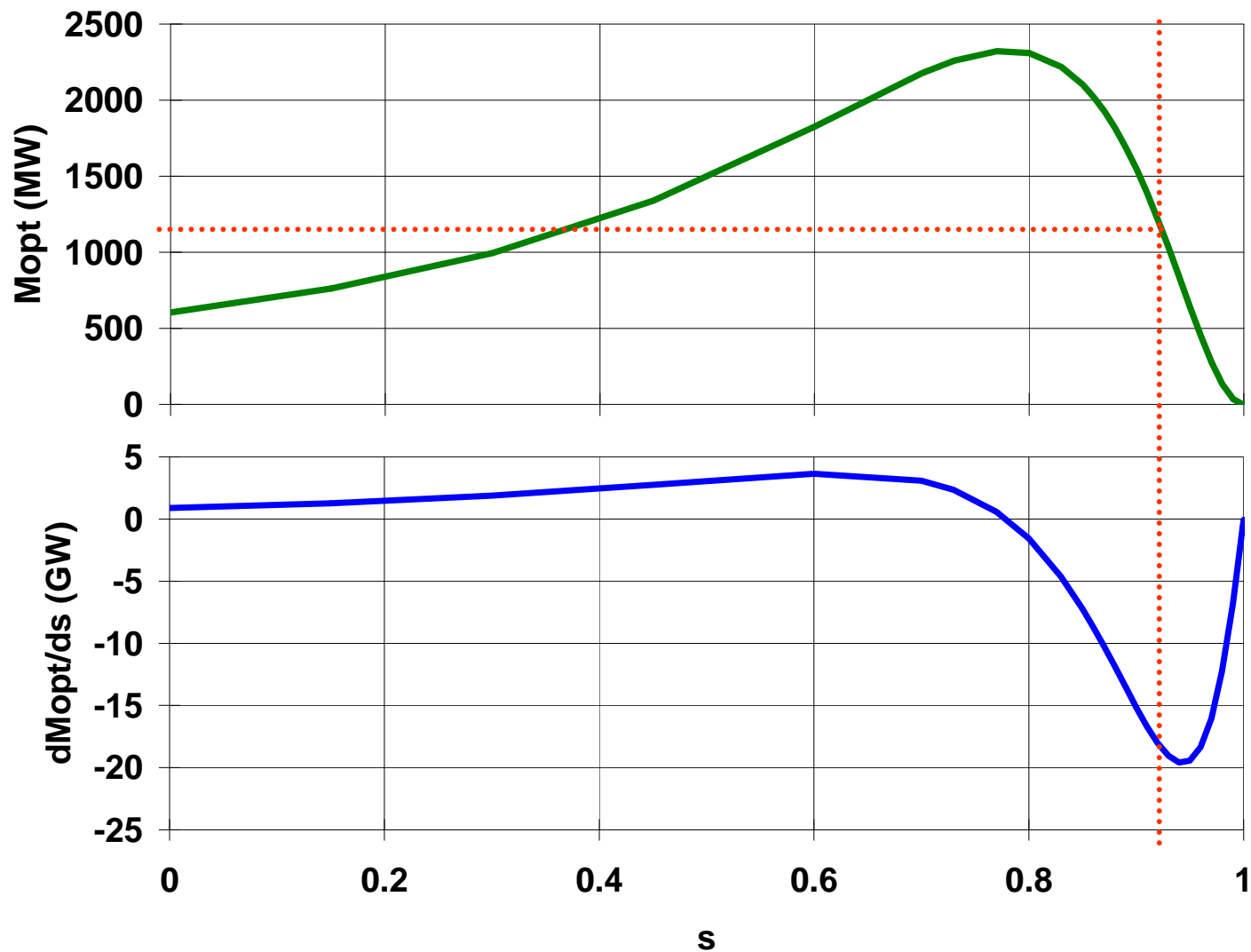

Cost Functions in Optimization

$M_{opt}=1252$ MW
constant s

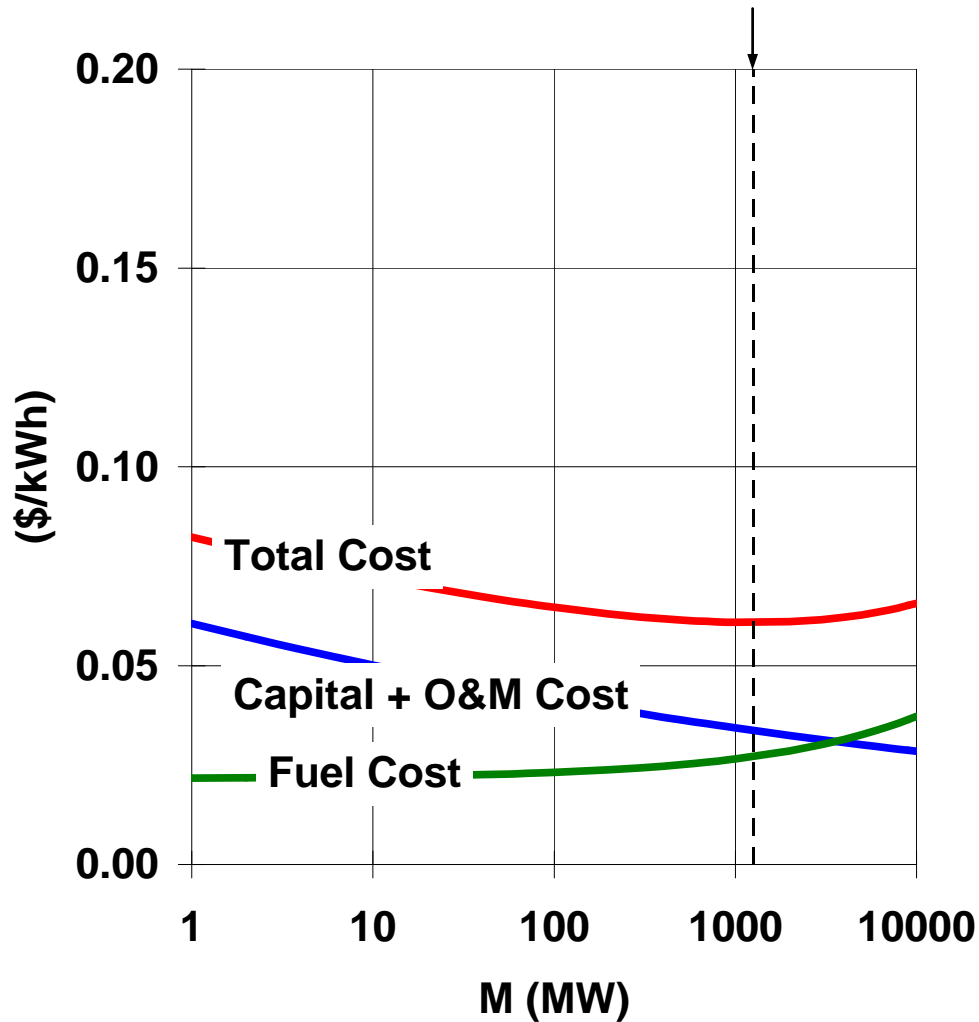

$M_{opt}=305$ MW
variable s

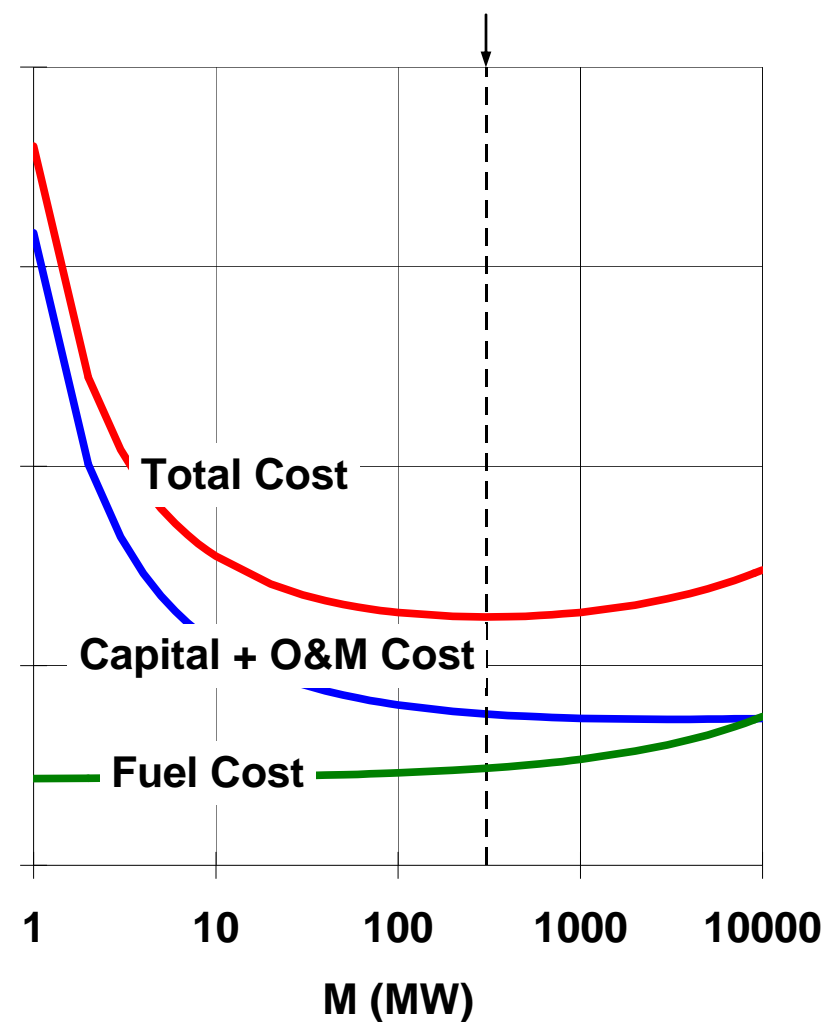

US Highway Transportation System (2005)

Total miles of highway*	3,995,635
Number of highway vehicles	247,421,120
Highway vehicle miles traveled (trillions)	3.0
On-highway fuel consumption (billion gallons)	173.8
Equivalent CO₂ emissions (million metric tons)	1,959
Average US highway vehicle fuel economy (mpg)	17.2
Average highway traffic volume (vehicles/hour)	85
Average equivalent CO₂ emissions (lb/gallon)	24.8

*public roadways.

Sources: *USDOT Bureau of Transportation Statistics; US Energy Information Administration.*

Scale: Offset Biomass Production Area

Average 85 vehicles/hour traffic volume
(43,291 gallons gasoline equivalent/mile-year)

Annual Increment:

5 tons/acre-year

1 mile

80 tons/acre-year



538 feet
(65 acres/mile)

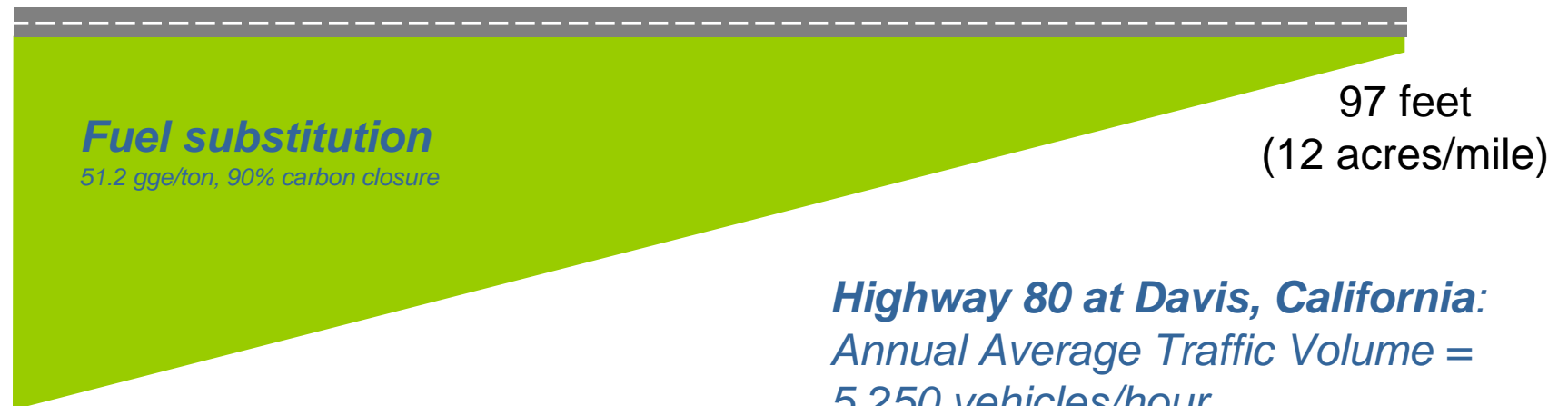

1,550 feet
(188 acres/mile)

Highway 80 at Davis, California:

Annual Average Traffic Volume =
5,250 vehicles/hour

Peak hour: 11,100 vehicles/hour

(Cal DOT Traffic and Vehicle Data Systems Unit, 2006 data)

Production costs and prices

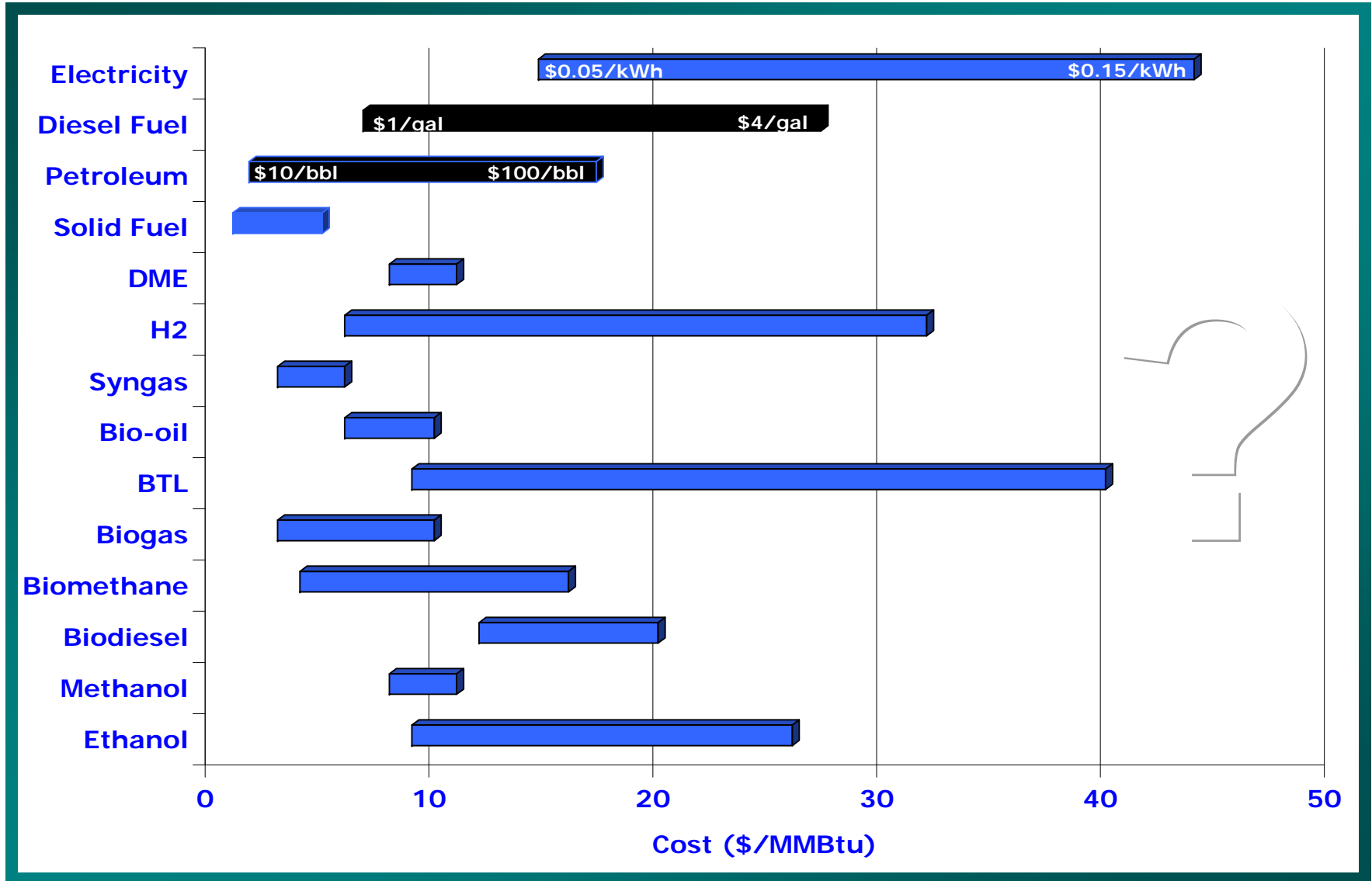

Federal Ethanol Cost Targets

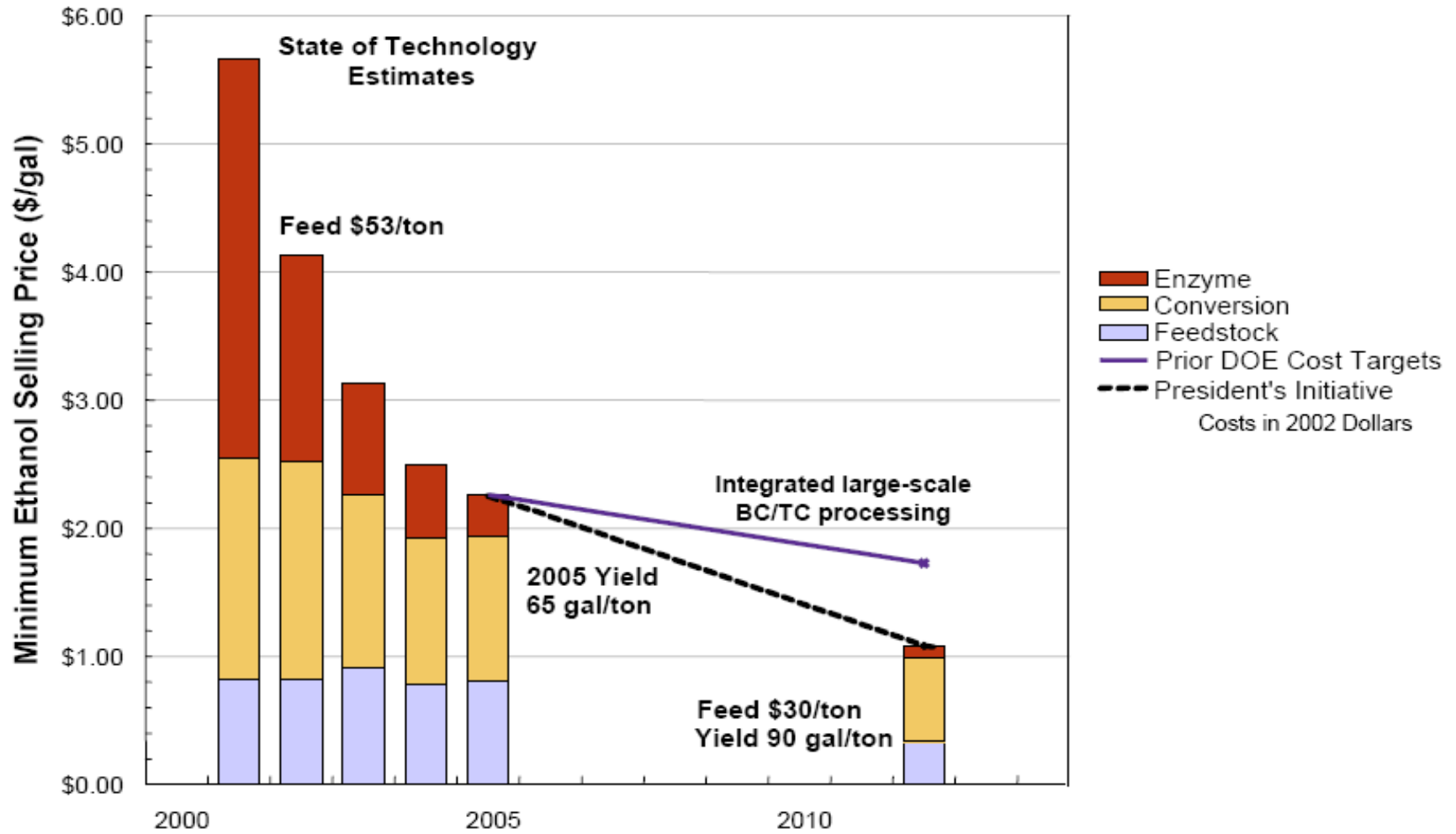

DOE Cellulosic Biorefinery Demonstration Project Awards, 2007-2010, \$385M

Awarded to	Ethanol Capacity (MGY)	Technology	Feedstock (tpd=tons per day)	Location	Award (\$ Million)
Abengoa	11.4 (cellulosic) 85 (starch) + power and syngas	Enzymatic hydrolysis + biomass gasification for process energy	700 tpd corn stover, wheat straw, switchgrass, others	Kansas	76
ALICO	13.9 + power, 8 tpd hydrogen, 50 tpd ammonia	Gasification followed by syngas fermentation (BRI)	770 tpd greenwaste and energycane	Florida	33
BlueFire Ethanol	19	Concentrated acid hydrolysis (Arkenol process)	700 tpd sorted greenwaste and wood waste from landfill	California	40
Broin (POET)	31 cellulosic 94 starch	engineered Zymomonas bacteria (Dupont)	842 tpd corn fiber, cobs, stalks	Iowa	80
logen Biorefinery Partners	18	Enzymatic hydrolysis (logen)	700 tpd wheat and rice straw, other ag. residues, switchgrass	Idaho	80
Range Fuels	40 + 9 methanol	Gasification followed by catalytic syngas upgrading	1,200 tpd wood residues and energy wood	Georgia	76

DOE Cost Goals

- **Ethanol**
 - **\$1.07/gallon**
- **Hydrogen**
 - **Previous goal of \$1.50/gge (~\$1.50/kg)**
 - **New goal of \$2.00 – 3.00/gge**
 - **delivered, untaxed, 2005 \$Constant by 2015**

Lifecycle ethanol GHG emissions relative to gasoline

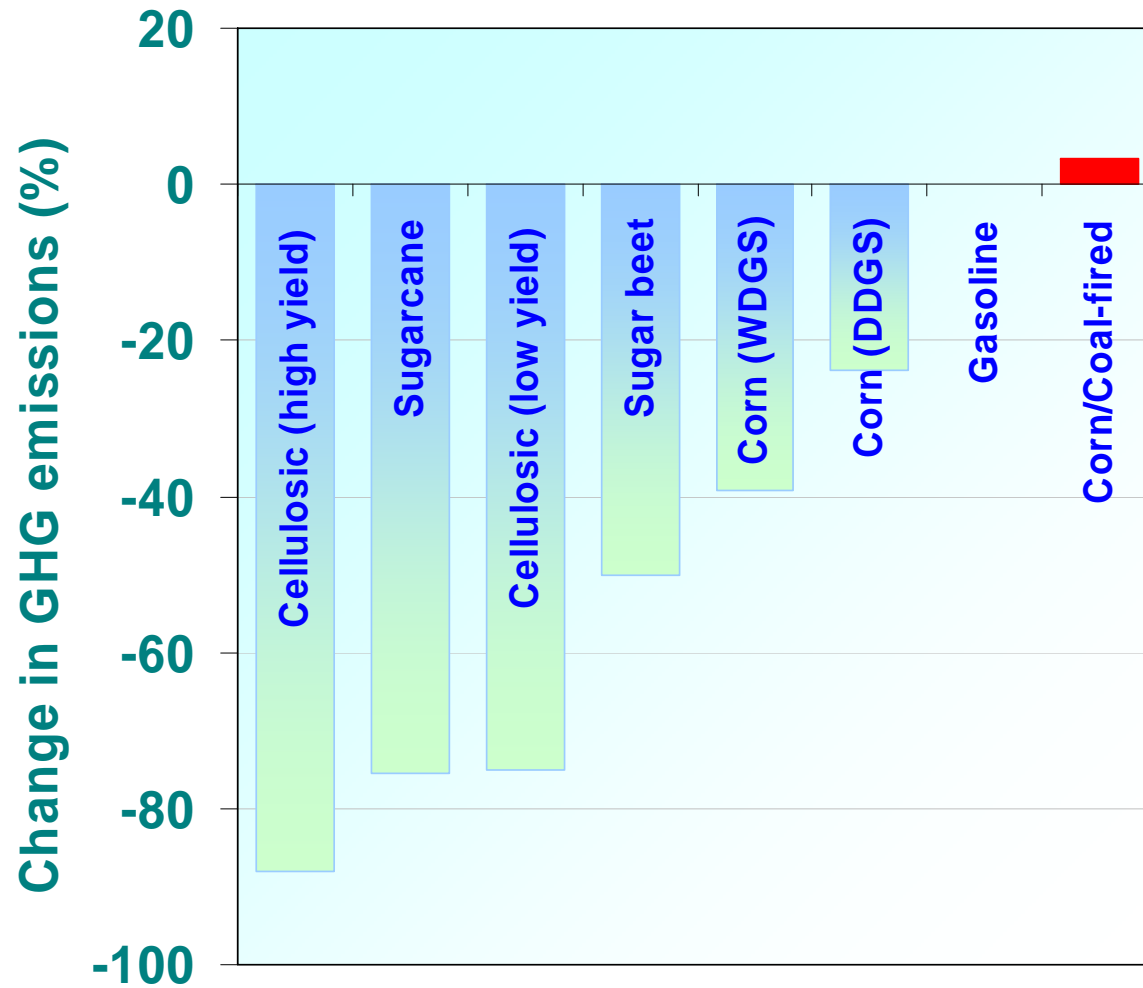

based on R.B. Williams, 2006

Lifecycle renewable-diesel GHG emissions relative to diesel

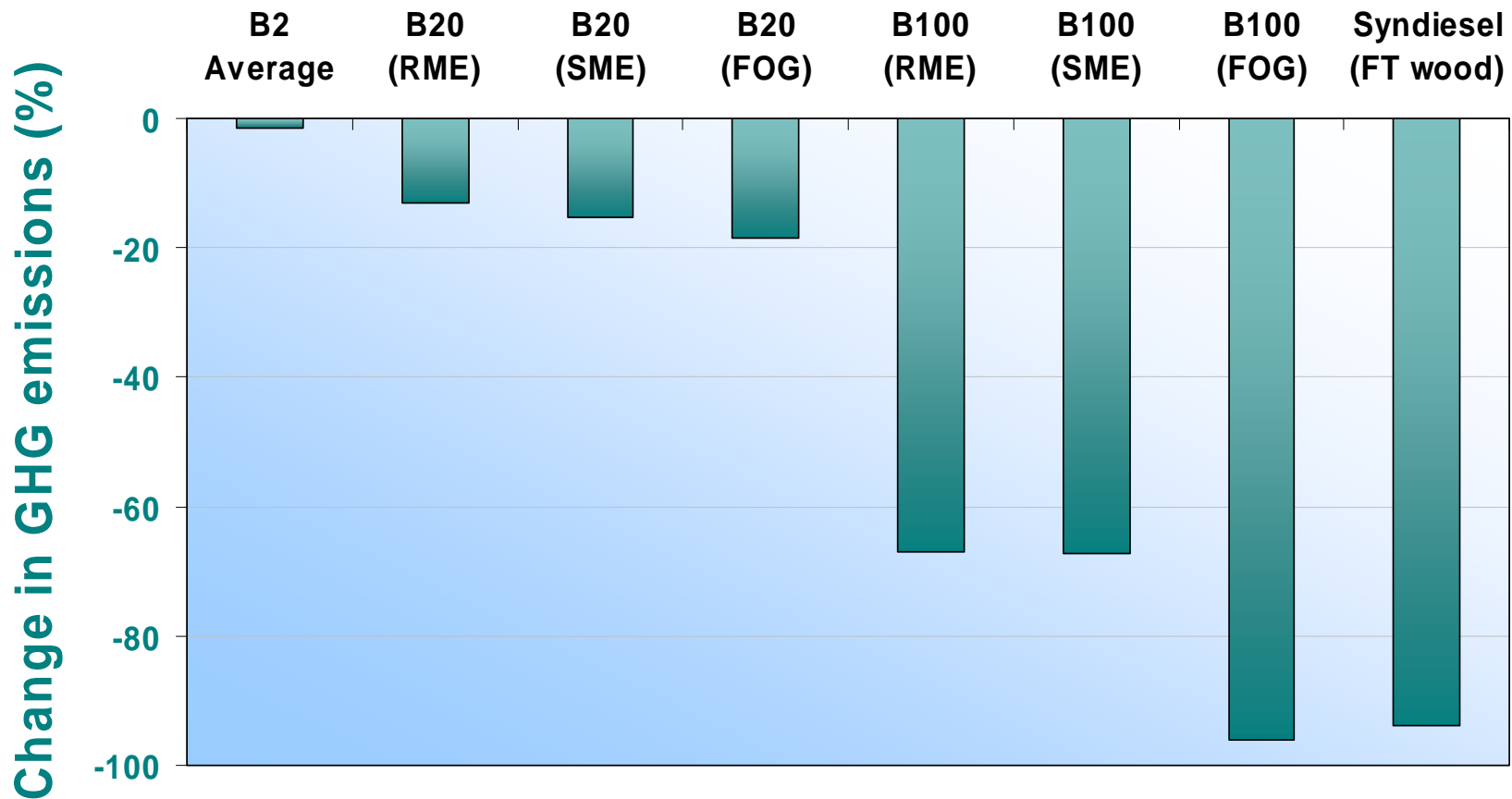

California Low Carbon Fuel Standard

- **UC Berkeley and UC Davis LCFS study report**
 - **Part I: Technical Analysis**
 - **Part II: Policy**



LCFS

- **Defines carbon intensity metric (at-the-wheel)**

$$AFCI = \frac{\sum_i (CI_i \eta_i) E_{im}}{\sum_i E_{im}} \leq \overline{LCFS} \quad \text{g CO}_2\text{e/MJ}$$

AFCI = firm's average fuel carbon intensity (g CO₂e MJ⁻¹)

\overline{LCFS} = set standard (g CO₂e MJ⁻¹)

CI = fuel carbon intensity at the tank or plug (g CO₂e MJ⁻¹)

η_i = fuel energy conversion efficiency to motive energy (–)

E_{im} = total motive energy for each fuel (MJ) = $E_{it} \eta_i$

E_{it} = total fuel energy at tank or plug (MJ)

Representative Fuels

Fuel type	Description	AFCI gCO ₂ e/MJ
Gasoline	California average	92
Average Midwest corn ethanol	Current	76
Mid-GHG ethanol	Corn feedstock, modern dry mills Natural gas, natural gas (wet DGs), stover	58
Low-GHG ethanol	Poplar, switchgrass, prairie grasses Cellulosic production	4
Mid-GHG biodiesel	Soy feedstock	38
Low-GHG biodiesel	California poplar Gasification and Fischer-Tropsch	-6
Electricity	California average	27
Hydrogen	Steam methane reforming	48

Source: A. Farrell, UC Berkeley

Biofuel Production Issues

- **Performance and Cost**
- **Sustainability**
 - Life cycle impacts including land use
 - Climate change and other environmental, ecosystem, environmental justice, and regional economic impacts
 - Standards
- **Resource and end product potentials (Scale)**
 - Fuel substitution potential
 - Policy influences

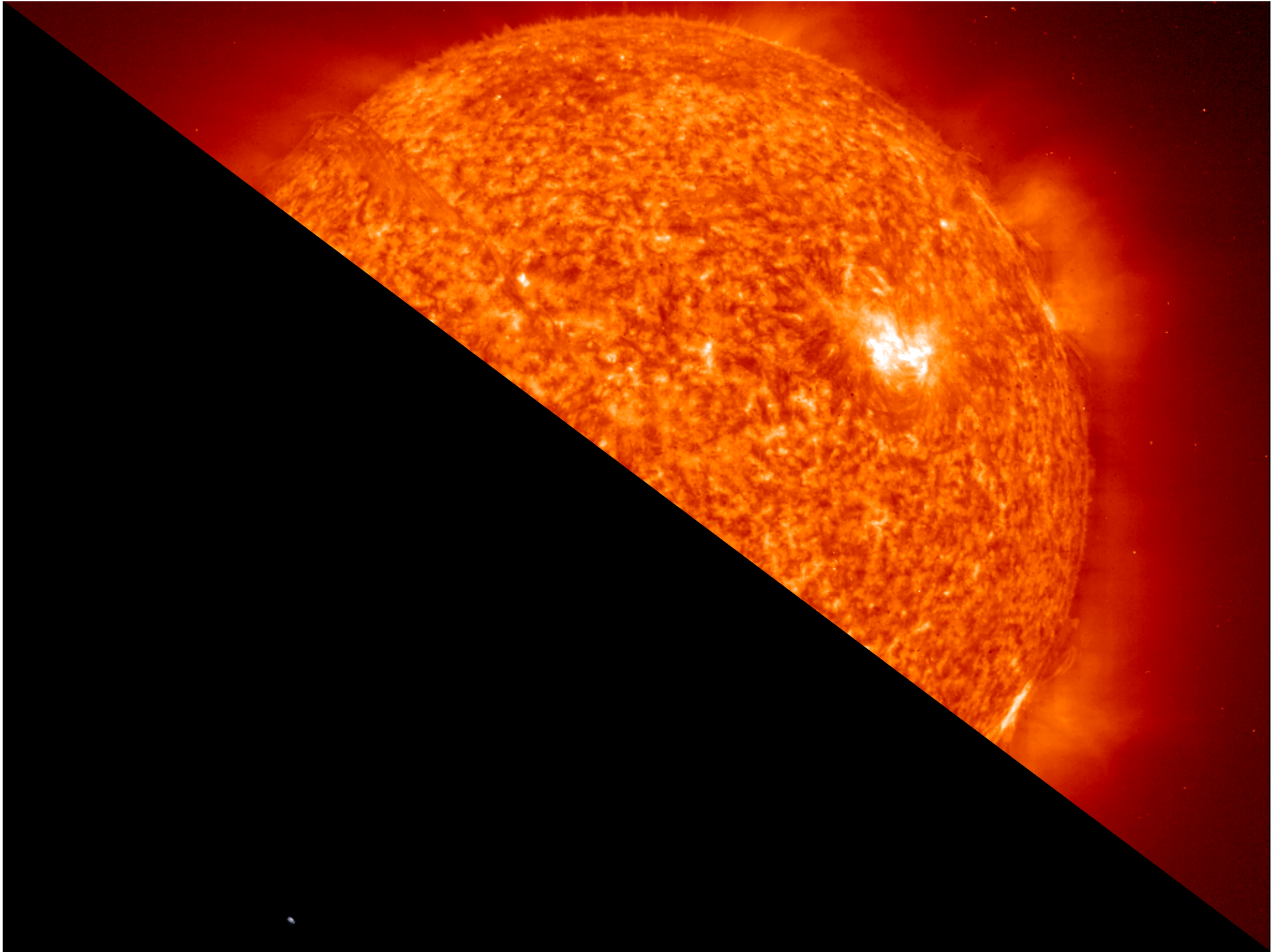

Biofuels

- **Thermochemical Conversion**
- Biochemical Conversion
- Physicochemical Conversion

Thermal Gasification

Fuel + Oxidant/Heat

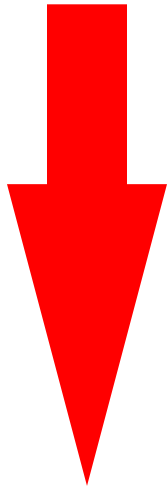

Partial Oxidation/Air or Oxygen
Steam/Water/Carbon Dioxide/Hydrogen
Indirect Heating

CO + H₂ + HC + CO₂ + N₂ + H₂O +
Char + Tar + PM + H₂S + NH₃ +
Other + Heat

Biomass Gasification

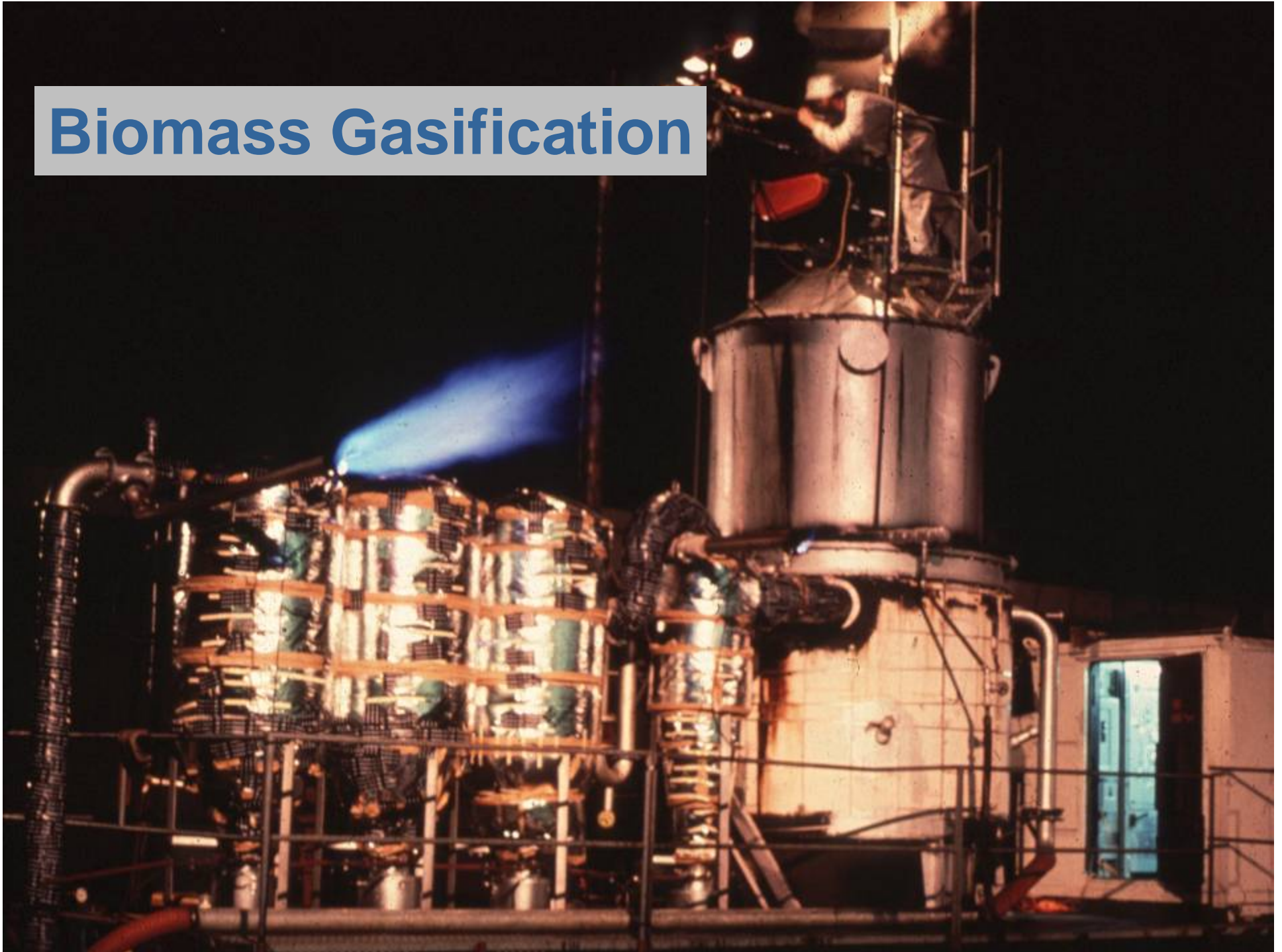

Classification by Reactor Type: Fixed/Moving (Stirred) Beds

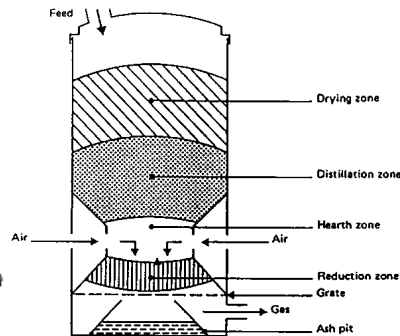
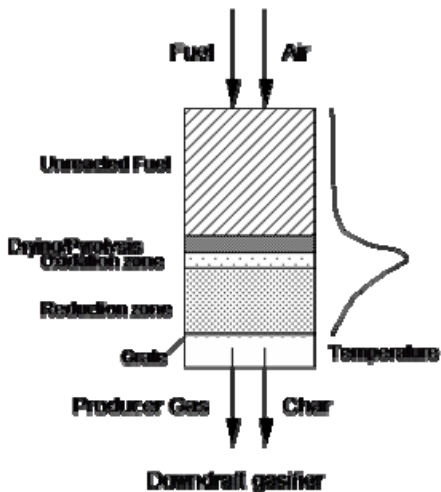
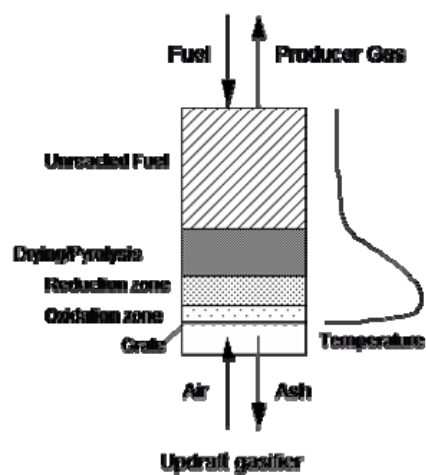

- **Updraft**

- Countercurrent
- High moisture fuel (<60% wet basis)
- High tar production except with post-reactor catalytic cracking or dual stage air injection
- Low carbon ash

- **Downdraft**

- Cocurrent
- Moisture < 30%
- Lower tar than uncontrolled updraft
- Carbonaceous char

- **Crossdraft**

- Adaptation for high temperature charcoal gasification

Classification by Reactor Type: Fluidized Beds

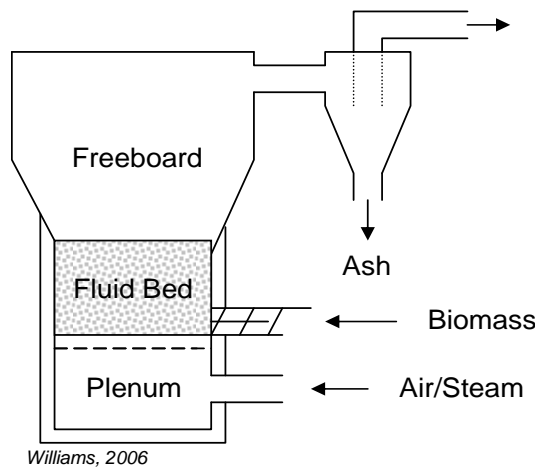

- **Bubbling beds**
 - Lower velocity
 - Low entrainment/elutriation
 - Simple design
 - Lower capacity and potentially less uniform reactor temperature distribution than circulating beds

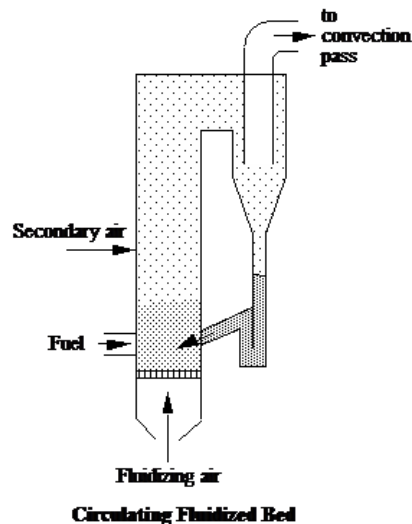

- **Circulating beds**
 - Higher velocity
 - Solids separation/recirculation
 - More complex design
 - Higher conversion rates and efficiencies

Classification by Reactor Type: Entrained Beds

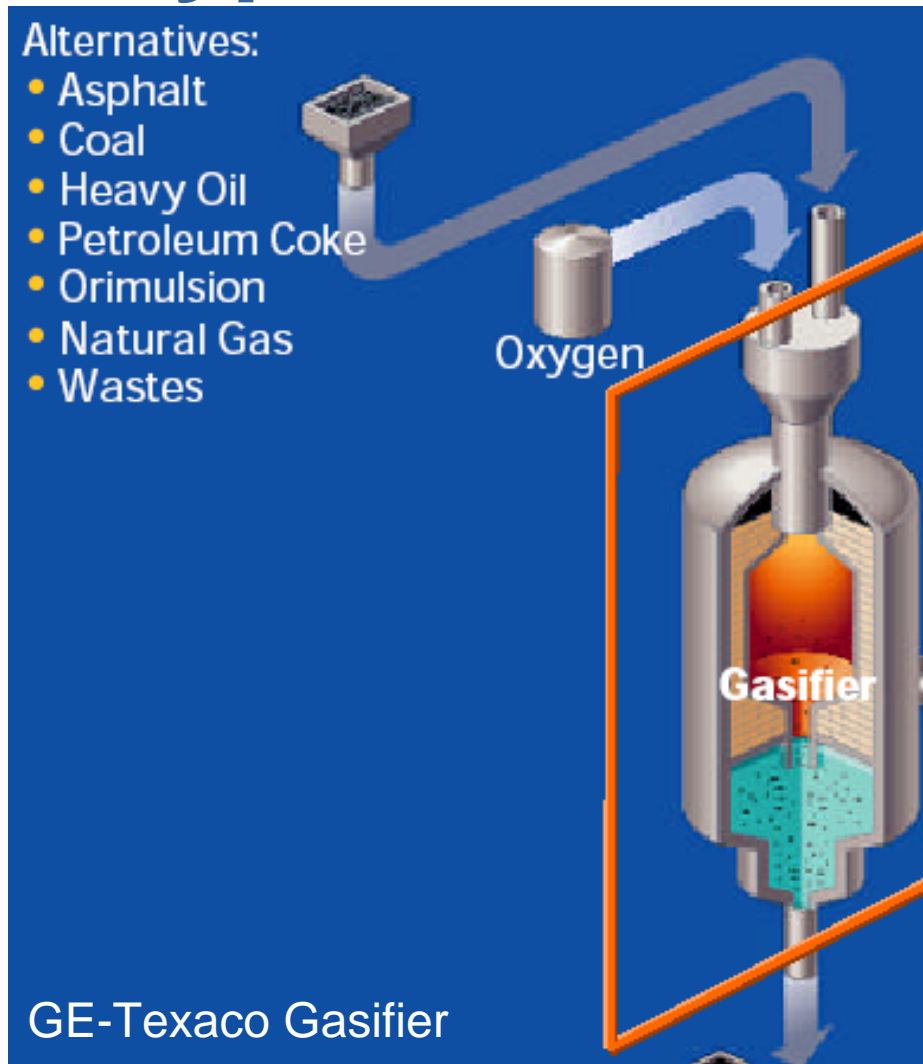

- Solids or slurry entrained on gas flow
 - Small particle size
 - Entrained flow used as component in some developmental pyrolytic biomass reactor systems

Gasification: Indirect Heating

Battelle/ FERCO gasifier

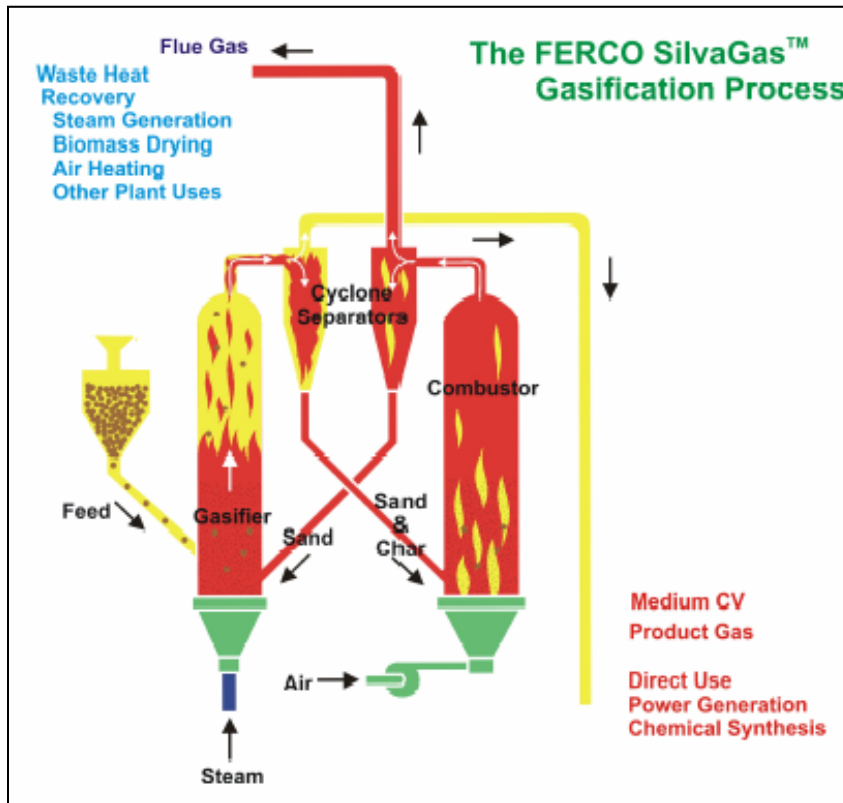

Mark Paisley, FERCO

Fast Internal Circulating Fluidized Bed (FICFB) gasifier, Güssing, Austria

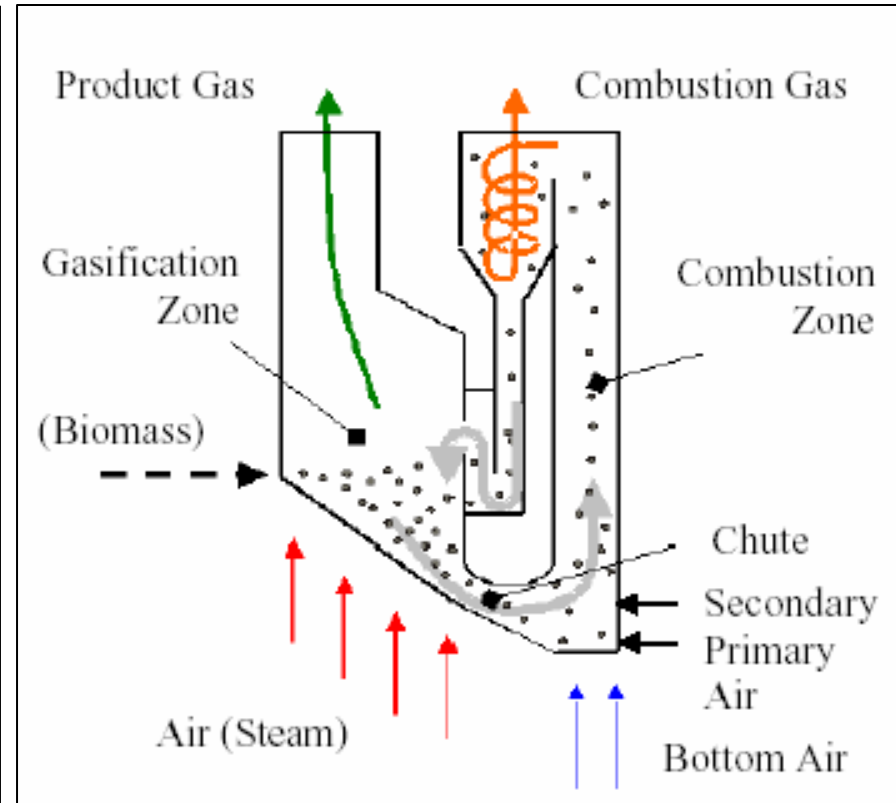

Bolhar-Nordenkampf, et al. (2002)

Wet Gasification

- **Catalytic hydrothermal gasification**
 - **250 – 360°C, 22 MPa (3,200 psi)**
 - **Ruthenium-based catalysts**
 - **Primary products: CH₄ and CO₂**
 - **Energy breakeven at solids content above 2 - 8%**
 - **Need to remove sulfur**

Thermo-biorefining

Syngas

• Direct use	Fe, Co, Ru	• Waxes, diesel	
• Fischer-Tropsch		• Olefins, gasoline	
	ThO ₂ , ZrO ₂	• <i>i</i> -C ₄	
• Isosynthesis	HCo(CO) ₄	• Aldehydes	
• Oxosynthesis		• Alcohols	
	Fe, Cu/Zn	• Hydrogen	• Ammonia
• Water-gas shift			
	Ni	• SNG	
• Methanation			
	ZnO/Cr ₂ O ₃ , Cu/ZnO/Al ₂ O ₃ , MoS ₂	• Mixed alcohols	
• Alkali-doped			
	Co, Rh	• Ethanol	
• Ethanol synthesis			
	Cu/ZnO	• Methanol	
• Methanol synthesis			
			• Direct use (M100, M85, DMFC)
	Al ₂ O ₃		• DME CH ₃ OCH ₃ (methanol dehydration)
	homol/Co		• Ethanol
	Ag		• Formaldehyde
	isobutylene		• MTBE
	Co, Rh, Ni		• Acetic acid
	zeolites		• Olefins, gasoline

BTL: Biomass To Liquids

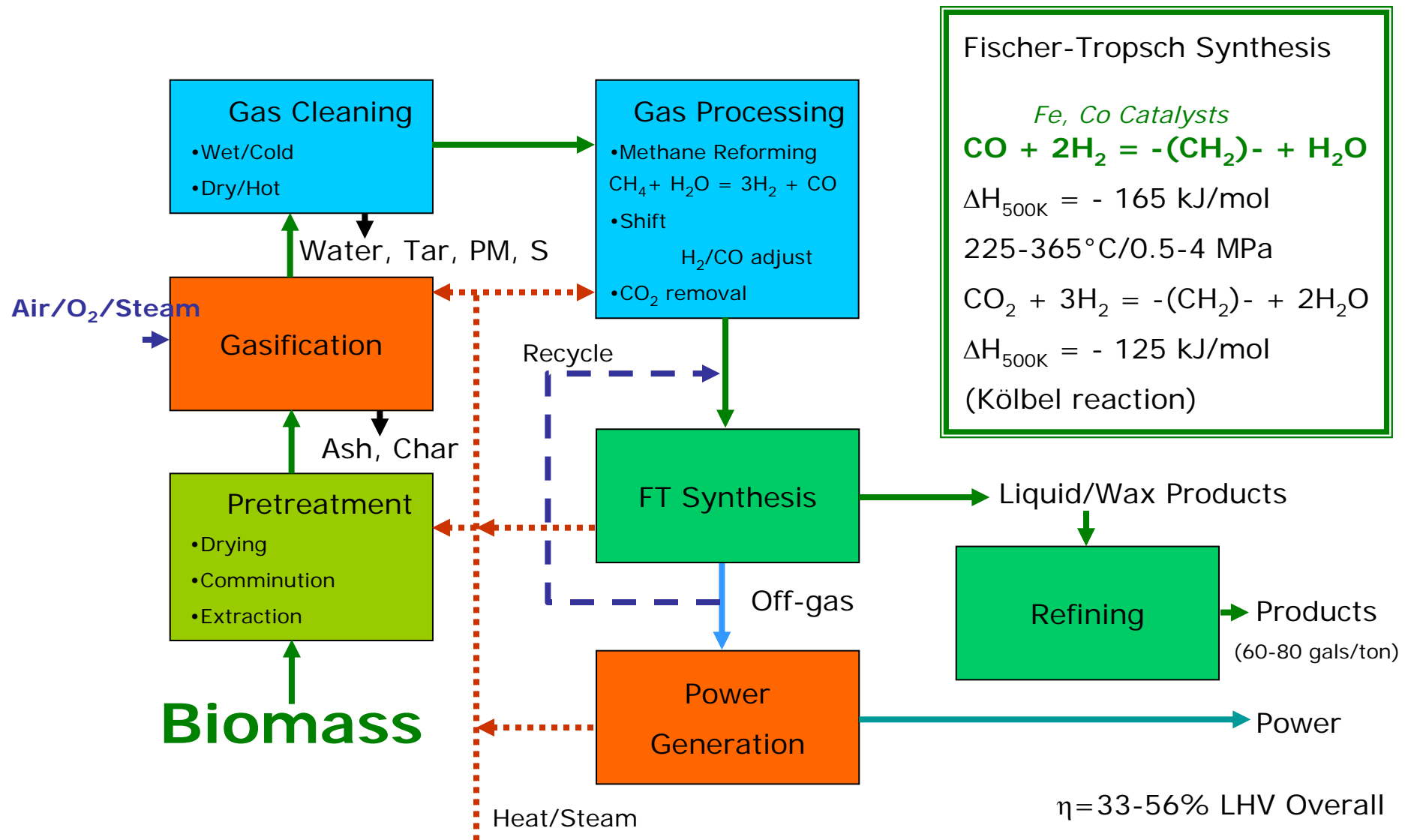

Fischer-Tropsch Synthesis

Fe, Co Catalysts

$\text{CO} + 2\text{H}_2 = \text{-(CH}_2\text{)-} + \text{H}_2\text{O}$

$\Delta H_{500\text{K}} = -165 \text{ kJ/mol}$

225-365°C/0.5-4 MPa

$\text{CO}_2 + 3\text{H}_2 = \text{-(CH}_2\text{)-} + 2\text{H}_2\text{O}$

$\Delta H_{500\text{K}} = -125 \text{ kJ/mol}$

(Kölbl reaction)

$\eta = 33\text{-}56\%$ LHV Overall

FT Biofuel Production Cost

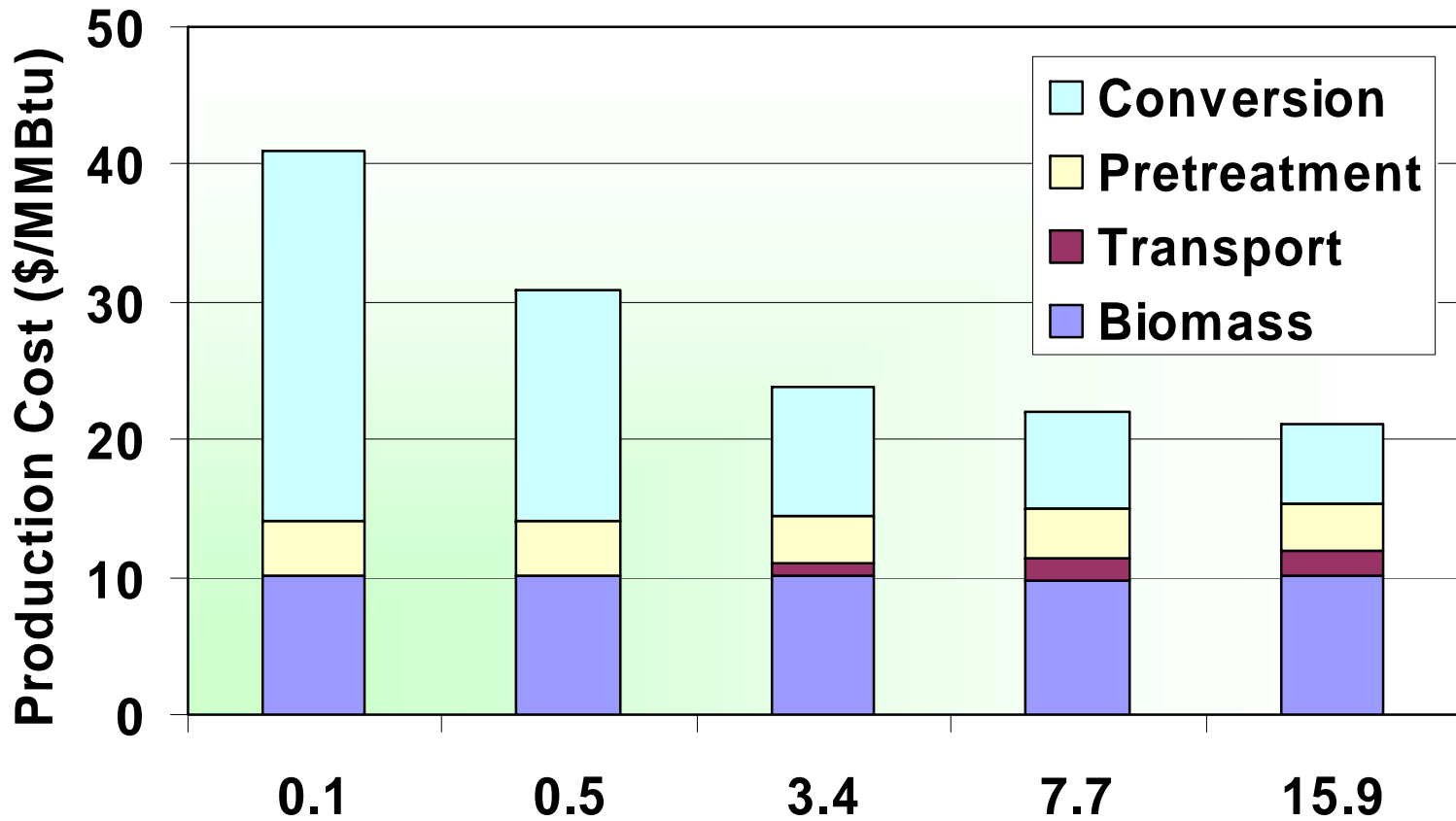

Biomass (Million tons per year)

MWth	50	250	1,800	4,100	8,500
bbl/d	425	2,125	15,300	34,849	72,248

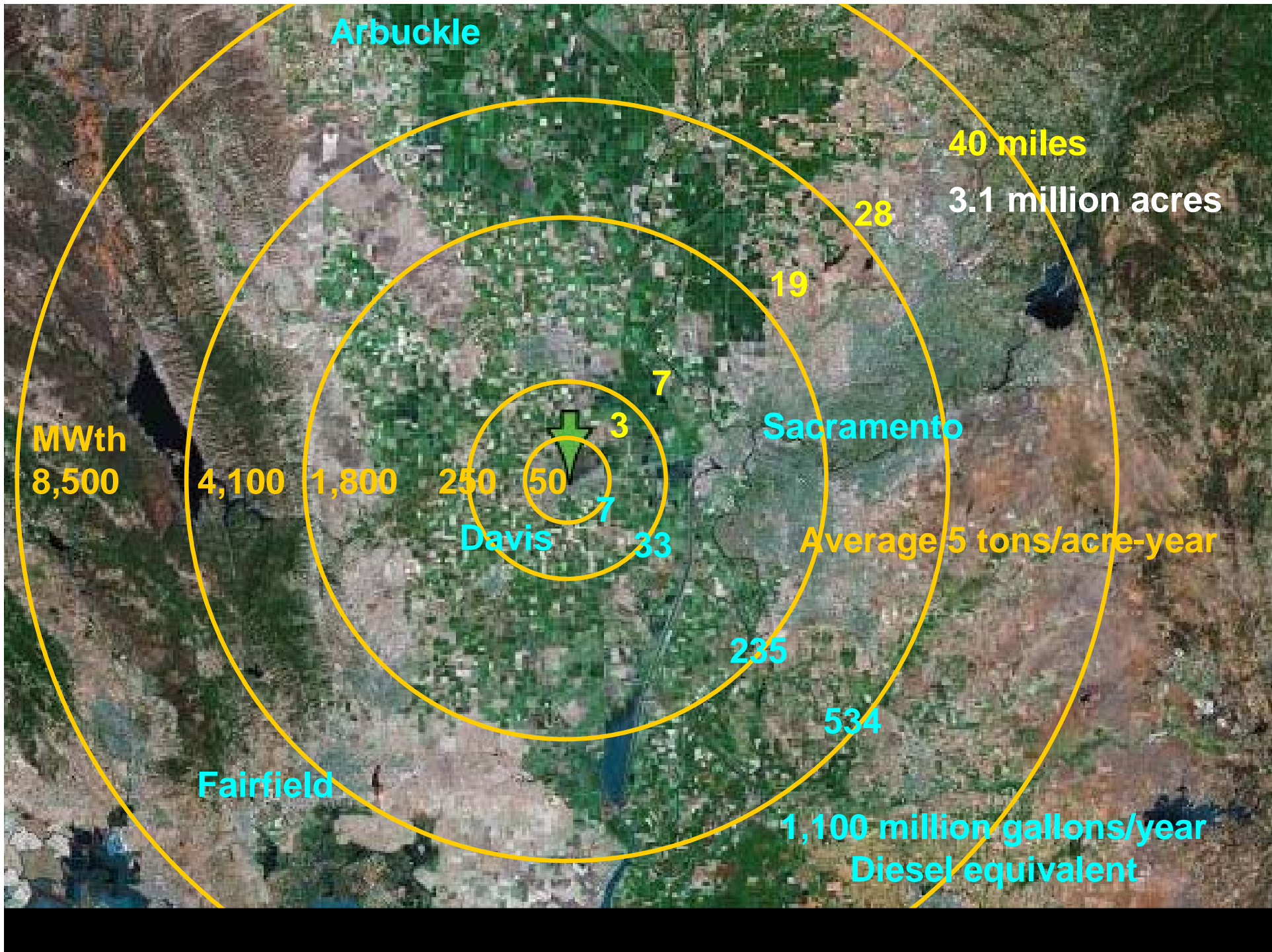

Pyrolysis

- **Thermally degrade material w/o the addition of air or oxygen**
- **Similar to gasification – can be optimized for the production of fuel liquids (pyrolysis oils), with fewer gaseous products (may leave some carbon as char)**
 - **Fast/Flash pyrolysis**
- **Temperature range (typical): 750-1500°F**
- **Can utilize catalysts to promote reaction (Catalytic cracking)**

Pyrolysis oils

- **Liquids used in a number of applications**
 - Crude liquids as boiler fuel
 - Commercial consumer products, adhesives, other
- **Crude liquids may be suitable for further processing and refining**
 - Potential petroleum refinery integration
 - Crude bio-oils of low quality
 - Poor oxidative stability
 - Aqueous and solid phases
 - Corrosive
 - Toxicity
- **Potential intermediate product for increasing scale of biofuel production facility**

Hydrogen from Biomass via Thermochemical Conversion

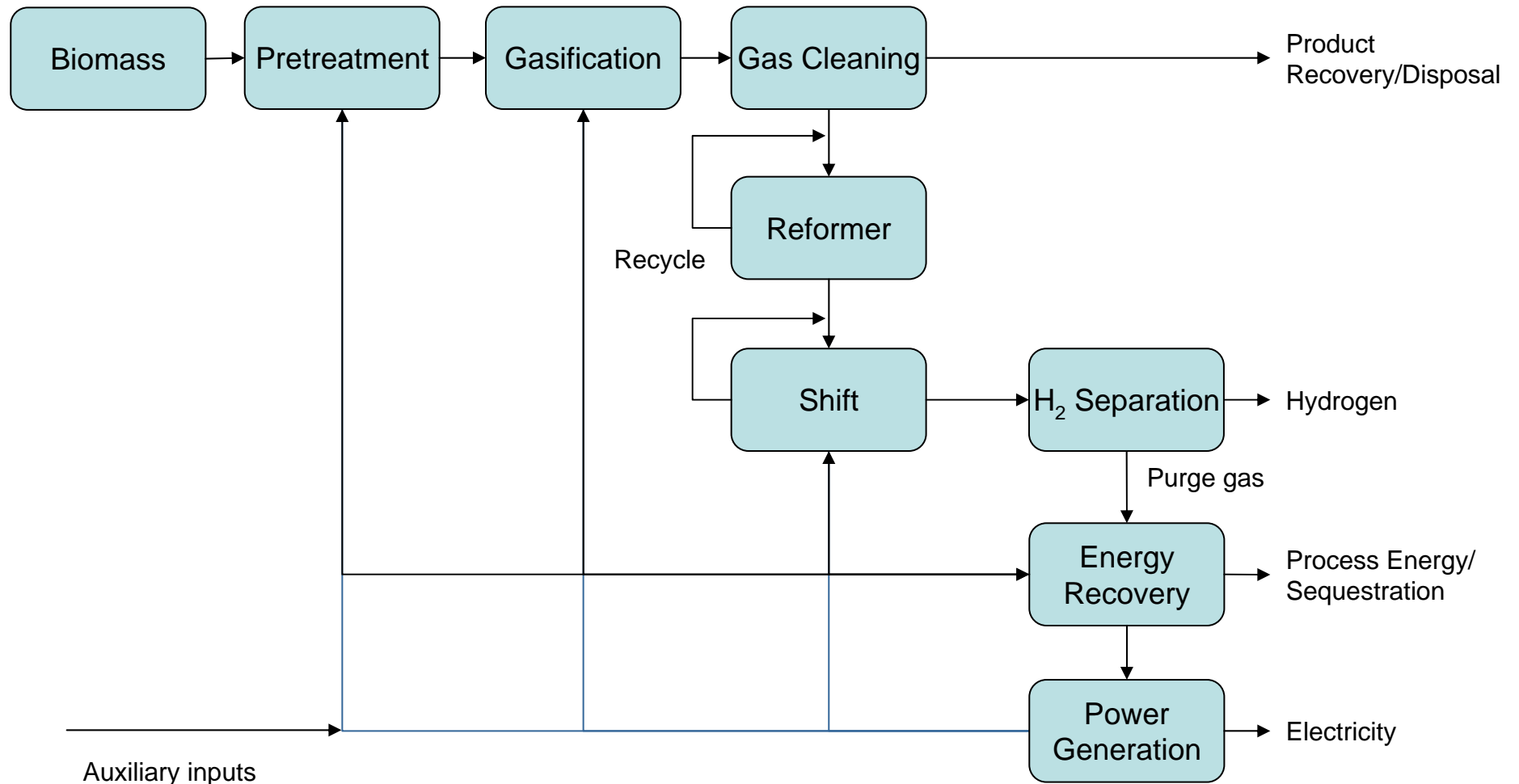

Hydrogen from Biomass

- Estimated plant gate costs vary substantially
 - \$1 – 5/kg

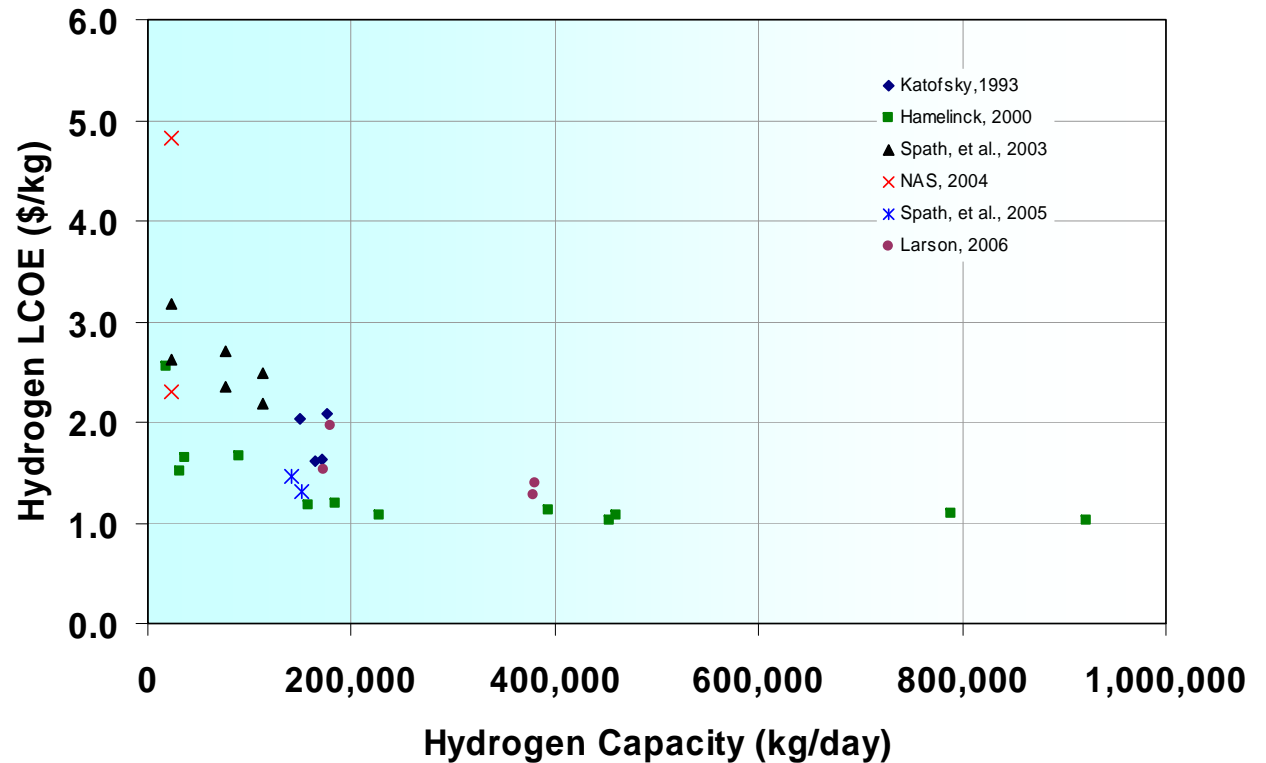

Delivered Costs of Hydrogen

- Biomass (rice straw) to H₂ analysis (Parker, 2006)
 - Sacramento Valley

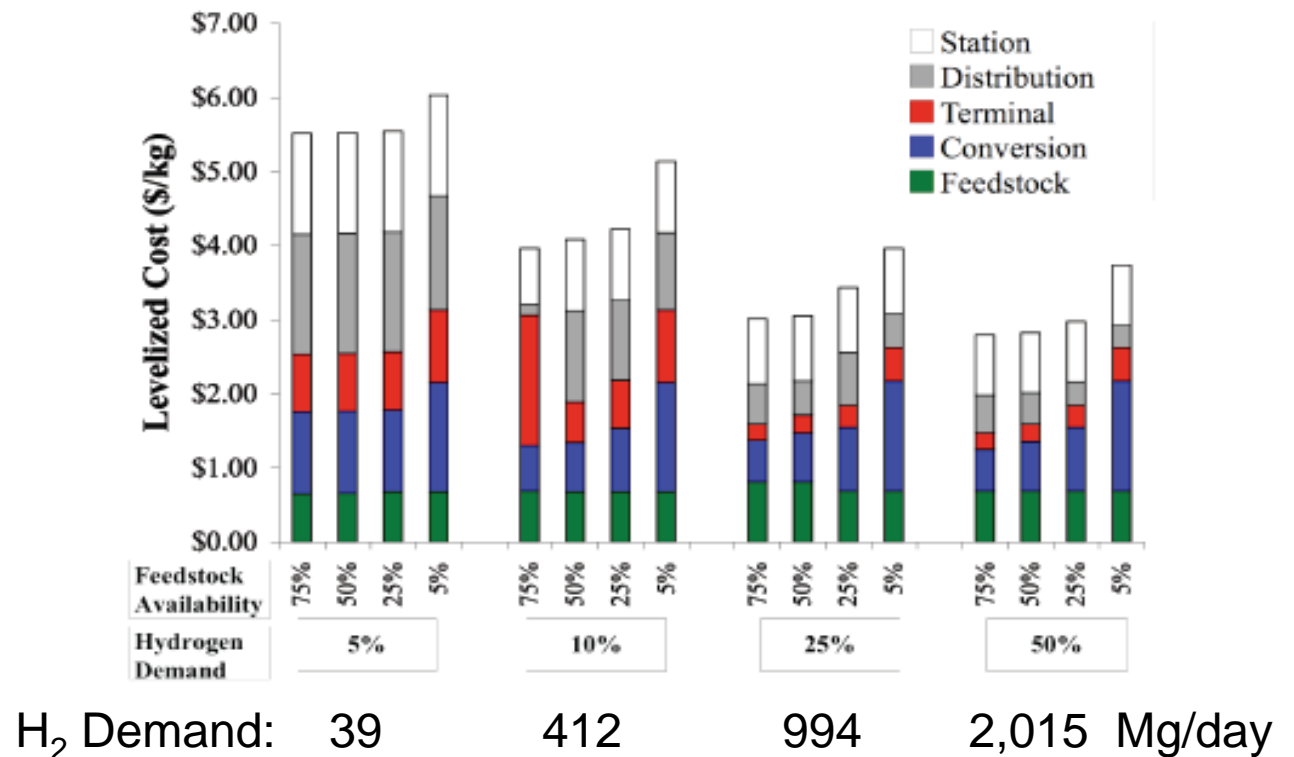

Biofuels

- Thermochemical Conversion
- **Biochemical Conversion**
- Physicochemical Conversion

Ethanol Fermentation

- Ethanol ($\text{C}_2\text{H}_5\text{OH}$) is widely produced by fermentation and is the predominant liquid fuel derived at present by biochemical means from biomass.
- The overall reaction for the fermentation of glucose to ethanol is



- Cellulosic feedstocks (such as wood and herbaceous biomass) are less expensive to produce than corn grain and represent a large resource for fuel ethanol production with potentially better net energy yields and lower environmental impacts.
- They are more difficult to hydrolyze into monosaccharides and ferment, however, incurring more costly pretreatment.
- Current methods under development for cellulosic biomass hydrolysis and fermentation essentially fall into four categories:
 - 1) concentrated acid hydrolysis,
 - 2) dilute acid hydrolysis,
 - 3) enzymatic hydrolysis, and
 - 4) thermochemical conversion (gasification and pyrolysis)

Ethanol Fermentation:

Starch

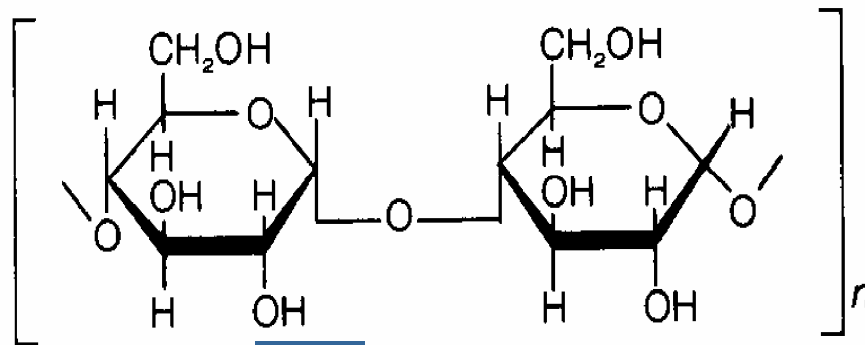



Hydrolysis

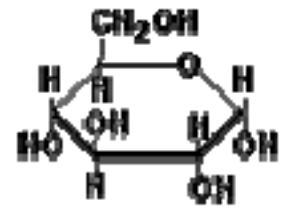

(1) GLUCOSE

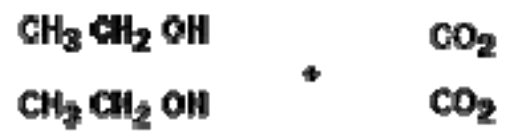

(2) ETHANOL + (2) CARBON DIOXIDE

- Known technology
- Basis for corn grain-ethanol industry
- Efficiency improvements continuing
- Uncertainties regarding sustainability
- Sugar feedstocks similarly fermented (e.g. sugar from sugar cane in Brazil)

Cellulosic Fermentation

- Pretreatment
 - Size reduction/grinding
 - Acid (dilute or concentrated)
 - hemicellulose hydrolysis
 - Heating
 - Steam explosion/AFEX, others
- Hydrolysis (cellulose depolymerization--glucose release)
 - Acid
 - Enzymatic
- Fermentation of sugars (C5 and C6)
 - Separate
 - Simultaneous saccharification and co/fermentation (SSF; SSCF)
- Product Recovery and Purification
 - Distillation and dehydration
 - Lignin separation (unfermented)

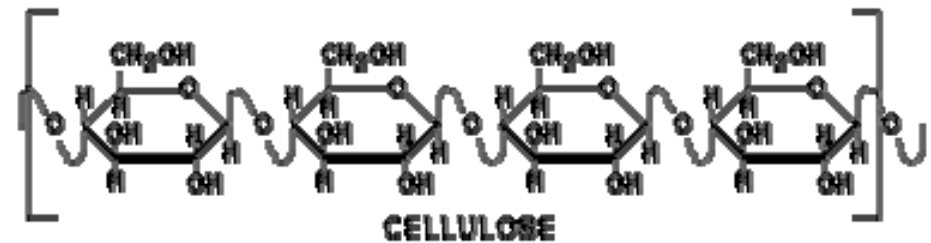
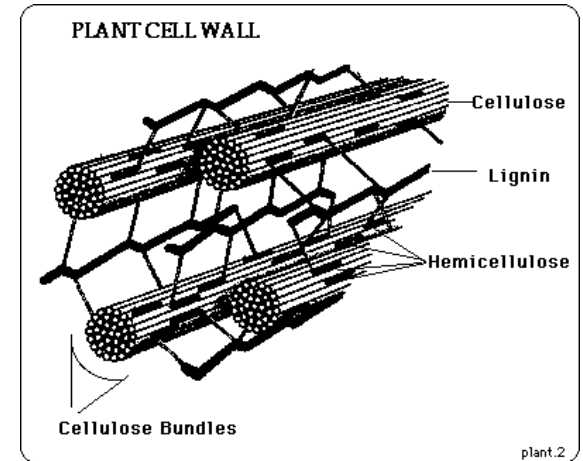

HYDROLYSIS

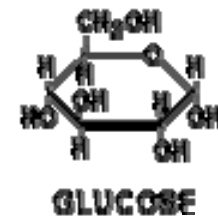
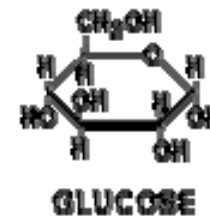

Butanol fermentation

- Butanol ($\text{CH}_3(\text{CH}_2)_3\text{OH}$) has higher heating value per gallon (energy content) than ethanol and is less hygroscopic
- Acetone-Butanol-Ethanol fermentation pathway
- *Clostridium beijerinckii*,
C. acetobutylicum
- Gas stripping

Anaerobic Digestion

- Electricity
- Heat
- Biogas upgrading
 - Pipeline quality
 - CNG
 - LNG
 - Gas-To-Liquids (GTL)
 - Other chemical synthesis



Biogas for
Power or
Biofuel
Upgrading



Onsite
And
Grid Power,
Fuels,
Chemicals

Anaerobic digestion for biogas generation

- California Dairy Power Production Program (CEC)
- European-California collaborations



Biofuels

- Thermochemical Conversion
- Biochemical Conversion
- **Physicochemical Conversion**

Biodiesel (FAME, FAEE)

- **Transesterification**
 - Reaction between lipid and alcohol using alkaline catalyst
 - Fatty acid methylester (FAME)—oil + methanol/NaOH or KOH
 - Fatty acid ethylester (FAEE)— oil + ethanol/KOH or NaOH
- **Reduced viscosity, improved atomization**
- **Improved emissions (uncertainties regarding NO_x)**
- **Lower Toxicity**

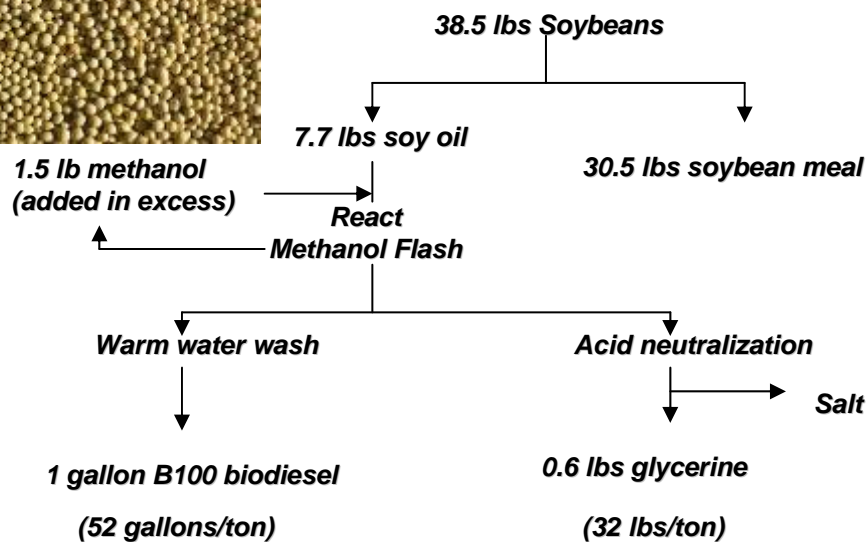

Renewable diesels include:

- Biodiesel esters
- Hydrotreatment, hydrothermal upgrading of vegetable oils and animal fats, other lipids and esters (e.g. Shell, Neste, Petrobras)
- Fischer-Tropsch diesels from biomass
 - FT diesels sulfur free
 - Wide product spectrum including gasolines, diesels, alcohols, waxes, aviation fuels, higher value consumer products
- E-Diesels (ethanol-diesel blends)—partially renewable if blending with petrodiesel
- Straight vegetable oils (engine warranty, coking, cold weather issues)
- Bio-oils (pyrolysis derived)
- Thermal depolymerization

- Differences in air emissions among fuels likely, limited data available on emerging fuels