



# Horse Mastership Book

July 8 & 9, 2017



## 4-H Horsemastership Schedule

<u>1st Year</u>	10:00	Showmanship - Arena
	11:00	Written Test - Under Trees New Arena
	11:30	Grooming, Saddling, & Bridling
	1:30	Equitation - Arena
<u>Horseless</u>	10:00	Demonstrate Showmanship Skills - Arena
	11:00	Written Test - Under Trees Near Arena
	11:30	Grooming, Saddling, & Bridling
	1:30	Grab Bag Oral Presentation - Place to be announced
<u>2nd Year</u>	10:00	Written Test - Under Trees near Arena
	11:00	Showmanship - Arena
	11:30	Grab Bag Oral Presentation - Place to be Announced
	1:00	Equitation - Arena
<u>3rd Year</u>	10:00	Judge Halter Class/ Oral Reasons with 4 <sup>b</sup> Year members - Round Pen
	11:45	Showmanship - Arena (with 4th, 5th & 6th year Members)
	12:30	Written Test - Under Trees near Arena
	2:00	Equitation -Arena (with 4th Year)
<u>4th Year</u>	10:00	Judge Halter Class/ Oral Reasons with 3d Year Members - Round Pen
	11:00	Oral Review of Research Paper - Place to be Announced
	11:45	Showmanship - Arena (with 3rd, 5th & 6th Year members)
	12:30	Written Test - Under Trees near Arena
	2:00	Equitation - Arena (with 3rd Year)
<u>5th Year</u>	8:30	Oral Review of Focus Paper, Focus Presentation, & Focus Demonstration
	10:00	Written Test - Under Trees near Arena
	11:45	Showmanship - Arena (with 3rd, 4th & 6th year members)
	2:00	Judge 3rd & 4th Year Equitation with official judge followed by oral reasons
<u>6th Year</u>	8:30	Oral Review of Focus Paper, Focus Presentation & Focus Demonstration
	10:00	Judge 1st Year Showmanship with official judge followed by Oral Reasons
	11:00	Written Test - Under Trees near Arena
	11:45	Showmanship - Arena (with 3rd, 4th & 5th year members)
<u>7th, 8th, 9thYear</u>	8:30	Watch Focus Presentations
	12:30	Riding Pattern– Arena
	11:30	Written Test - Under Trees near Arena
	2:45	Teach Riding Clinic– Arena

### New This Year

**4th year and above—2:45 pm - Riding Clinic taught by 7th, 8th and 9th year members**

This is mandatory, but will not be included in your points for Saturday. Please come dressed in your appropriate western or English riding gear. It will be a fun, learning, educational test of your riding skills.

# General Information and Suggestions

## Date

July 8 & 9 2017

## Location

The 2017 Horsemastership and Horse Show will be held at the Plumas-Sierra County Fairgrounds.

Breakfast, snacks and lunch will be available for sale from "We Cook for You", both days or you may bring an ice chest with your own food.

## Camping

Camper hookups are \$20 per night., and requires proof of insurance. Tent camping is \$10 per night. Camping application must be filled out. Stall fees are \$5 per day. Please include all fee with entry form- only one check made out to Plumas- Sierra 4H.

## Horse Stalls

If you plan to keep your horse at the fairgrounds, stalls will be provided. You will need at least two days worth of feed and bedding for your stall. You will also need a large bucket for water and a smaller one for your grooming supplies. You should bring a halter, lead rope, and whatever other tack you'll need for showing your horse. An extra snap to secure the stall door is a good safety precaution. A short hose will also come in handy.

4-H members will be responsible for cleaning their own stalls during and after the show, so you should bring a pitchfork and shovel. It is suggested that members allow extra time to check and, if necessary, clean their stalls before using them. You are responsible for cleaning your stall *before* you leave the fairgrounds following the show. In the past, a few individuals have ended up cleaning most of the stalls. This is not right! It is advisable for each club to select someone to check and assure that members comply. You must have your stall checked and signed off by the designated Horsemastership staff member announced during the show before you leave the grounds.

*Please note:* 4-H members are charged a \$5/day stall fee by the fairgrounds for stall use. However, if stalls are not cleaned, with manure/bedding hauled to the designated area prior to leaving the fairgrounds on Sunday, members will be charged \$20 in addition to stall fee. Parents will sign a statement to this effect when signing the participation consent form.

## Dress

Dress neatly and appropriately for showing your horse both Saturday and Sunday. Boots, long pants, and ASTM/SEI approved helmets with a secured chin harness are required. For Saturday, 4-H uniforms, including dark pants, a white long or short sleeve button-up shirt, a belt, a 4-H tie, and a 4-H hat are suggested. It is recommended that you bring a swimming suit if you plan to go swimming and a jacket for the evenings.

**\*\* For both the Saturday and Sunday show, short sleeve shirt must be over the shoulder (down the arm). NO SLEEVELESS OR TANK TOPS ALLOWED, except for the gymkhana events on Sunday.**

## High Point

Members must attend both Saturday's and Sunday's events to become eligible for High Point. High Point awards are given based on the highest number of points earned in each age group, and are given after the show ends on Sunday. Members must be present during the high point presentation or forfeits any high point winnings.

# General Rules

## Members

The participant must be a bona fide 4-H Club member, currently enrolled in the Plumas-Sierra Counties Horse Project Program. A Horsemastership entry form will be provided only after the *Project Horse Identification Form*, and if necessary, a *Lease Form*, is returned to the 4-H office. Entries must be signed by the member's parent or legal guardian. In addition, the signature of the Horse Project Leader is **required** for participation in Horsemastership/Horse Show.

Horse Project members must participate in the proper Horsemastership year based on the members' project knowledge and experience as identified by their 4-H Horse Project Leader. Experienced and knowledgeable members should take the appropriate written tests from the previous year levels to be advanced to the proper Horsemastership year level. Tests must be taken before the 2017 Horsemastership. **Leaders**, please contact the Horsemastership Committee to receive these tests.

Horseless Project members will only be allowed to participate in Horsemastership at the first year level. From that year on, the year the Horse member is in the Horse Project will determine which year they will compete at Horsemastership.

Example: A member has been in the Horse Project for four years but has never participated in Horsemastership. That member may choose to compete in the first or fourth year level at Horsemastership.

The following year, that member will automatically be required to compete at the fifth year level.

**Horse Leaders**, please see to it that your members compete at their level and project year, so that it will be fair to all members participating in Horsemastership.

## Horses

Members may have more than one project horse and must turn in a *Project Horse Identification Form* for each horse by April 1, 2017. However, only one horse may be used for Horsemastership and members *must* specify to the 4-H office which horse they will be showing by May 1, 2017. **If these forms are not returned, members will not receive Horsemastership/Horse Show entry forms.**

Lease Rule: The long term lease, an agreement made for the use and full charge of a horse to a 4-H member, must be signed in triplicate. One copy is to be turned into the 4-H office by April 1 of the current year; one copy is for the lessee; and one copy is for the 4-H member. This lease will begin by April 1 and run through September 1 of the current year. If the member does not personally own a horse, and is not enrolled in the first year horseless project, the member must have a lease filed in the 4-H office by April 1 of the current year to participate in county 4-H horse events.

Horses must be the member's own or leased project horse, except in the event of the illness or injury of the horse. In such cases, a member may borrow a horse that has not already been entered. Illness or injury must be verified *in writing* to the 4-H office. The same horse shall be used on both days, with the exception of a different horse approved by the Committee for the Focus Project.

Horses shall be sound and healthy, well groomed, and have hooves properly trimmed or shod. Tack and equipment shall be clean and serviceable.

A mare with foal may be judged, however, the foal must be kept in the barn area, out of sight of the other horses being shown.

## Other Rules

*Decisions of the judge will be final.* Any interference with the judges or officials, or discourteous or un-sportsmanlike display toward them or other exhibitors will disqualify the participant. A ring steward will assist the participants and should not, in any way, attempt to influence the judges; any attempt to so will disqualify the participant. Profanity is considered un-sportsmanlike conduct and will result in disqualification.

Anyone causing a disruption in any way will be asked to leave.

Members are required to perform all care, grooming, training, and preparing of their horses themselves. While parents, leaders, and other non-members may hold horses, members *must* do their own work.

**Interpretation of rules at this county 4-H event will be made by the Horsemastership/Horse Show Committee.**

## Western Tack for Horsemastership

Bosal Hackamore, snaffle or other bit is allowed. A smooth, flat, ½ inch chain may be used as a curb strap, but a ½ inch leather curb strap is preferred. Tie downs, martingales, hackamore bits (mechanical hackamores), and draw reins are prohibited. Saddle should be of western type, serviceable, and must fit the horse and rider. Spurs, hobbles, rope or riete are optional. Roping reins are not advisable. A slicker is not required. A helmet is required. **A safety and equipment check may be made 15 minutes before the equitation class.**

## English Tack for Horsemastership

A snaffle, pelham, or full double bridles are allowed. Curb chains are allowed with pelham bits or double bridles, but not with snaffle bits. Tie downs, martingales, and draws are prohibited. Saddles should be of either hunt seat or saddle seat type. No bareback pads or riggins are allowed. Spurs are optional, but must be of unroweled type. Helmets are required. **A safety and equipment check may be made 15 minutes before the equitation class.**

## Horsemastership Scoring

The Danish System of Judging shall be used on Saturday. This system is based upon established standards of quality for each individual. In this system, each member is judged according to how well he or she met the standards rather than on comparisons with other participants.

<u>Quality</u>	<u>Score</u>	<u>Certificate Seal</u>
Group 1	80% and above	Blue
Group 2	65-79%	Red
Group 3	50-64%	White
Group 4	0-49%	Green

Each year level's total possible score is 100 percent. For each participant, the scores of all the show components will be added to determine the total percentage score. A minimum of 50 percent must be scored on the written test. Otherwise, the participant will be dropped to the next lowest certificate seal.

## Horsemastership Awards

Awards for Saturday's Horsemastership will be presented Saturday night after the BBQ. High Point awards are to be presented to the high scorer in each year level (a minimum score of 80 is required to receive the High Point award). Ties will be broken by written test scores. Certificates with seals will be given to all members.

# Showmanship

First, second and third year members will show in separate classes of showmanship. Fourth year and older will show in one class. If this class is too large, it will be split according to the Horsemastership Committee.

## Dress

See page 2.

## Tack

Presentable halter and lead suitable for showing a horse or pony. A lead chain shank is permissible ran under the horse's chin and up the other side and snapped with the snap facing out.

## Requirements

Horses shall be led into the ring, with two horse lengths between each horse (approximately ten feet), moving counterclockwise at the walk. The 4-H'er shall walk on the animal's left side, be holding the strap about 6-10 inches from the halter, with their right hand and the remainder of the strap **folded** neatly in their left hand. When asked to line up, the horse should be placed to stand squarely. The 4-H'er shall be required to walk and trot per the judge's instructions. Pattern will be

chosen by the official judge from pattern A or B on page 9 & 10 of this book. Pattern will be announced and posted Saturday morning. Remember, always turn to the right, pushing your horse around the turn. Don't pull.

4-H'ers will be judged on how well they set up their horses, their courtesy to the judge and other exhibitors, their ability to show their horses to the horses' best advantage, with emphasis placed on the 4-H'ers attention to the judge and to their horse, and how well the 4-H'er performs the requirements of the class. You should never come between your animal and the judge. The horse shall be shown according to the Quarter Method (see Diagram & Description).

Personal appearance shall be considered, and shall include condition of both horse and 4-H'er. **Breeding and conformation of the horse will not be considered in 4-H Showmanship.** 4-H Showmanship will be scored for each member and this will be a part of the total evaluation of the member's Horsemastership Performance Program.

## THE QUARTER METHOD: Suggested Guidelines of Movement

The following guidelines are meant to serve as an illustration of movement around the horse while showing in Showmanship at Halter and are for the exhibitor's information: Imaginary lines bisect the horse into four equal parts as seen in Figure A. (Note: The quadrants will be numbered I, II, III, IV for ease of identification.) One line runs across the horse just behind the withers. The other imaginary line runs from head to tail. When the judge is in I, the handler should be in IV. As the judge moves to II, handler should move to I. When the judge moves to III, the handler moves to IV. As the judge moves up the horse to IV, the handler returns once more to I. This method is based on safety as the handler can keep the horse's hindquarters from swinging toward the judge should the horse become fractious.

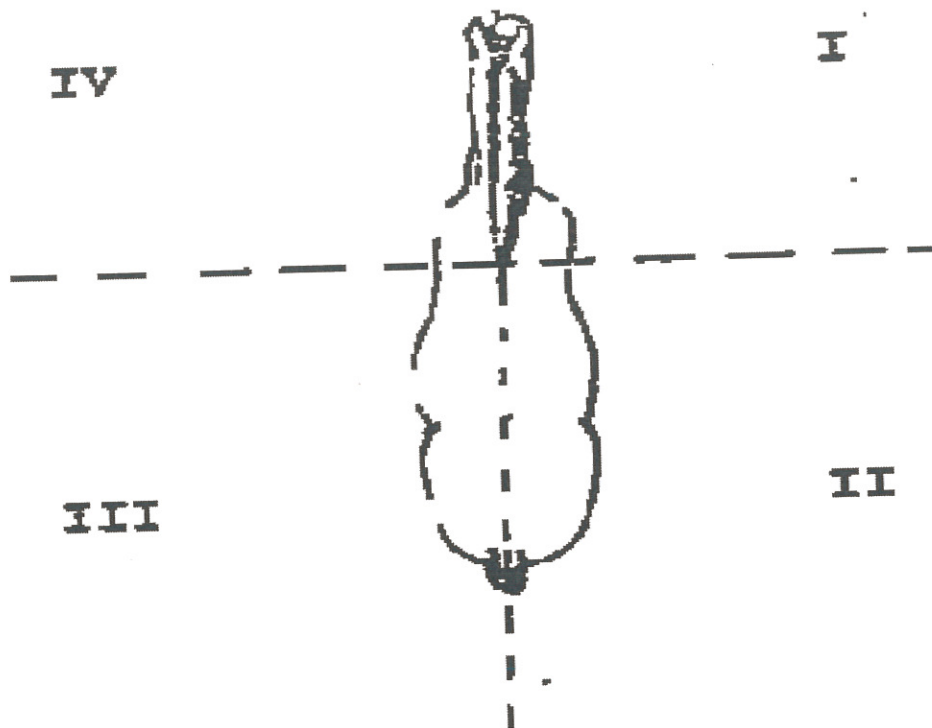

# Explanation of Showmanship Scorecard

A. Appearance of Animal ..... 40%

1. Condition and thriftiness should show normal growth, neither too fat nor too thin.

2. Grooming

- Hair should be properly groomed, and the hide soft and pliable.
- Hoofs should be trimmed and shaped to enable animal to walk and stand naturally, or properly shod and polished.
- Ears, face, tail, mane, legs and elsewhere should be clipped as needed.
- If the entire body is to be clipped, do it well in advance of the show.
- Body should be clean and free of stains.

3. Cleanliness

- Hair, tail and mane should be clean and free of stains.
- Hide, ears, nostrils and dock should be free of dirt, and legs and feet clean.
- Halter and lead strap or rope should be clean, neat and workman like.

B. Appearance of Exhibitors ..... 10%  
See page 1

C. Showing Animal in the Ring ..... 50%

1. Moving or leading

- Enter, leading the animal at the walk around the ring, walking slightly behind the head on the left side, holding the lead strap with the right hand about 10 inches from the halter with strap neatly but naturally (not coiled) gathered in the left hand.
- Animal should lead readily and respond quickly.
- Halter should be of right type, properly fitted and correctly placed on animal. A leather halter is not necessary.
- Lead slowly with animal's head held to look alert, stylish, and for attractive carriage and graceful walk.
- When you are asked by the judge to show the action of the animal at the walk and trot, lead horse in a straight line away from and back to the judge. After leading animal away from judge, stop momentarily, and then turn in a clockwise direction before coming back.

2. Posing

- When posing and showing your horse, move to the right or left of the horse, but always face the judge.
- Pose your horse with its feet placed as squarely under him as possible.
- Do not crowd the exhibitor next to you. Leave enough room for the judge to walk between horses.
- When judge requests that position be changed, do not disturb other horses in the class. Do not lead your horse between the judge and a horse he is observing.
- Show with the halter lead strap, and do not step on the animal's feet to move them. Do not use crop or stick for moving the horse.

- Move your horse forward and backward by a slight pull on the lead strap. Do not wrestle your horse to move him.
- When judge is observing your horse, let the horse stand if he is posed reasonably well.

### 3. Show Animal to Best Advantage

Quickly recognize the conformation faults of the animal you are leading and show in a manner as to overcome them.

### 4. Poise, Alertness and Attitude

- Keep an eye on your animal and be aware of the position of the judge at all times. Do not be distracted by persons and things outside the ring.
- Show animal at all times and not yourself.
- Respond rapidly to requests from the judge and officials.
- Be courteous and sportsmanlike at all times.
- Keep showing until the entire class has been placed and the judge has given reasons.

### Showmanship Pattern A

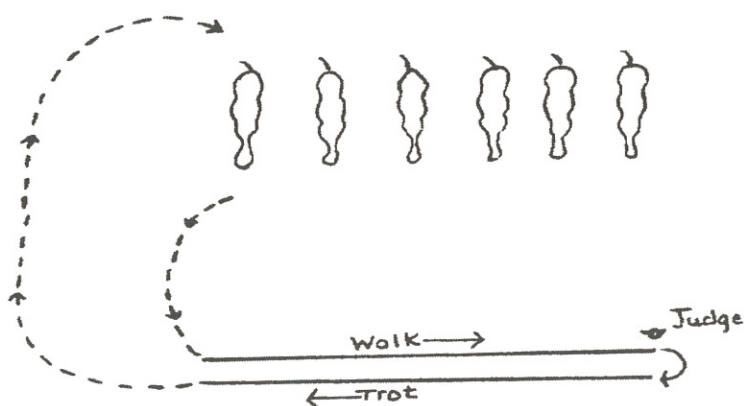

Member shall enter the ring leading the horse counter clockwise and continue to show as directed by the judge. When called by the judge the members are to lead their horses in and line up facing the announcers stand. Each member will be called from the line up individually to perform the pattern.

The member shall lead their horse out of the line up, walk the horse as indicated in the pattern above to the judge, pause, set the horse up, and then as directed by the judge, turn and trot away to a point determined by the judge. At that point stop and wait for the judge to dismiss you.

The Judge may include a back up in the pattern.

## Showmanship Pattern B

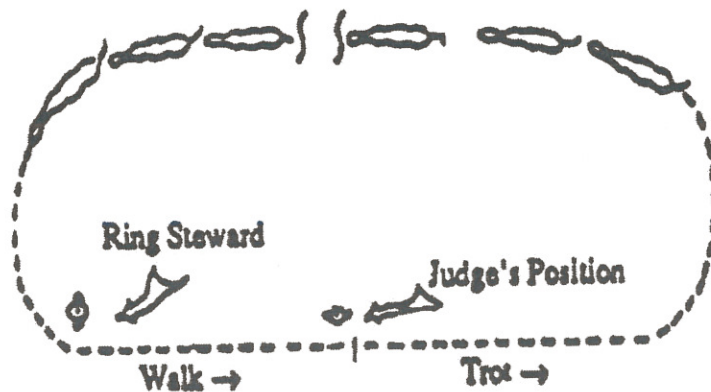

The class is lined up head to tail at one side of the arena. Each horse is lead to a point indicated by the judge or ring steward. This point should be in a straight line to the position assumed by the judge. The horse should be set up for inspection by the judge unless directed other wise. The judge shall call each member individually from the front of the line to lead their horse as indicated in the pattern. The member shall walk their horse to the half way point, stop, set their horse up, and then trot their horse away as directed by the judge (see pattern) The member then leads their horse and assumes a place at the end of the class line.

The Judge may include a back up in the pattern.

# Western Equitation

Judging emphasis is placed upon the rider in equitation classes. Riders will be judged on seat, hands, ability to control and show horse, and suitability of horse to rider.

Results as shown by performance of the horse are NOT to be considered more important than the method used by the rider in obtaining them.

No attendant shall be allowed in the ring except at the request of the judge.

## Basic Position

A. Rider should sit in saddle with legs hanging straight and slightly forward to stirrups or knees slightly bent and weight directly over balls of feet. In either position, the stirrup should be just short enough to allow heels to be lower than toes.

B. Body should always appear comfortable, relaxed and flexible.

C. Feet should be placed in the stirrups with weight on ball of foot.

C. Consideration, however, should be given to the width of the stirrups which may vary on western saddles. If stirrups are wide, the foot may have the appearance of being "home" when in reality, the weight is being properly carried on the balls of the foot.

## Hand Position

A. Upper arms to be in a straight line with body, the one holding reins bent at elbow. Reins will be held in one hand when riding in a curb bit and cannot be changed during performance. Two hands must be used when riding in a snaffle.

B. Ends of split reins should be carried on the side of the reining hand. (A romal should be carried on the opposite side of the reining hand.)

C. Hand to be around reins if romal type reins are used. One finger is permitted between reins, if split reins are used, and rein ends must be hung on the same side of horse as rein hand. Reins are to be carried immediately above and as near to the saddle horn as possible.

## Position in Motion

A. All movements of horse should be governed by the use of imperceptible aids. Exaggerated shifting of the rider's weight is not desirable. The rider should sit to jog, not post.

B. The rider should be close to the saddle at the lope.

## Mounting and Dismounting

A. Horse should stand while mounting until given the signal to move out. Control the horse by taking the reins in left hand and adjusting reins evenly with enough tension to feel the bit and hold the horse steady. Ends of the reins fall on the near side while mounting.

B. Place left foot in stirrup (if necessary, twist stirrup with right hand).

C. Slip the right foot into the off stirrup.

D. To dismount, reverse above procedure.

## Class Routine

The horse should be in balance at all times, working off its haunches with its head at normal height. A western horse responds smoothly and instantly to all aids showing lightness and freedom of action. Note that first year members will perform the equitation pattern on page 16.

A. When on the rail, the class will enter ring at a walk or jog as requested and proceed in a counterclockwise direction. The class will be worked at a walk, jog, and/or lope, both directions of the ring, and should always be on the correct lead, riding without evidence of undue restraint.

B. The class may be asked to extend gaits, reverse at walk or jog, stop, and other individual performances as requested by the judge.

# English Hunt Seat Equitation

Judging emphasis is placed upon the rider in equitation classes. Riders will be judged on seat, hands, performance of horse, appointments of horse and rider, and suitability of horse to rider.

The results as shown by the performance of the horse are NOT to be considered more important than the methods used in obtaining them.

No attendant shall be allowed in the ring except at the request of the judge.

## Basic Position

A. The rider should present a workmanlike appearance of being with the horse and in light control at all times. An impression of lightness and suppleness should be conveyed.

B. The rider should sit a basic position with the eyes up and shoulders back, toes at a natural angle, heels down and ankles flexed in, and calf of the leg in contact with the horse slightly behind the girth. The foot must rest in the stirrup with the iron under the ball of the foot.

## Hand Position

A. The hands should be over and in front of the horses withers, with the palms turned in (down) with knuckles about 30 degrees inside the vertical.

B. The hands should be held slightly apart, and in a position to make a straight line from the horse's mouth to the rider's elbow.

C. All reins are to be picked up at the same time.

D. Method of holding the reins is optional; bight of reins may fall on either side.

## Position in Motion

A. The body should be vertical at the walk or slow trot, inclined forward at the posting trot and hand gallop, and half-way between the posting trot and the walk when at a canter.

## Mounting and Dismounting

A. To mount, take up the reins in the left hand and place hand on the wither. Face the horse at an oblique angle to the rear near the shoulder, grasp stirrup leather with right hand and insert left foot in stirrup and mount.

B. To dismount, the rider may either step down or slide down. The size of the rider must be taken into consideration.

## Class Routine

A. Contestants will enter the ring in a counter-clockwise direction at the trot. The order to reverse may be executed either toward or away from rail.

B. Light contact with the horse's mouth is required.

C. Upon command all entries will line up and any or all riders may be required to execute any appropriate tests. Judges may call for additional tests.

D. The class may be judged on the rail, individual pattern or in combination.

E. When individual tests are called for, the judge's opinion should rest on a 50-50 analysis of rail work and individual test.

# Horseless Project (First Year Only)\*

25% Part I      **Showmanship Class.**  
Horses will be available to the Horseless members for Showmanship class. See pages 4-13 for guidelines.

25% Part II      **Written Test**  
Written program on horse feeding, handling, safety, and parts of the horse, saddle and bridle. Test questions will be taken from CHA Composite Horsemanship Manuals. First year:  
(NB=New Book: Level One— pages 7-9, 11, 13-15. Level Three— pages 8-10 and 12-15)  
(OB=Old Book: Level One – pages 3, 7-10, and 15-17. Level Three – pages 8-10 and 12-15.)

25% Part III      **Grooming/Tacking**  
Member to demonstrate to an official judge ability in grooming, saddling, bridling with emphasis given to safety.

25% Part IV      **Grab Bag Oral Presentation on a tack item**  
Two minute impromptu grab bag speech on a specified tack item. Member to draw an item of a "grab bag" and give a 2 minute oral presentation on that tack item. Member will be given 5 minutes to prepare (after all members in the group have drawn an item). Example:  
Western Curb Bridle (member to include the following points in their presentation) Identify parts, tell how to correctly adjust the bridle on the horse, function or purpose of the tack item, care of the item for cleanliness and safety.

Note for leaders and parents: If your child has a reading disability and needs assistance, we can make arrangements to help, i.e.: an oral test. *Please let the 4-H Office know of any special situations prior to June 10th so needs can be met.*

\* For high point, First year horseless member's scores will be included with first year for one horseless/first year high point award.

# First Year Horsemastership Program\*

25% Part I:     **Showmanship Class**  
See pages 4-13 for guidelines.

25% Part II:    **Written Test**  
Written program on horse feeding, handling, safety, and parts of the horse, saddle and bridle. Test questions will be taken from CHA Composite Horsemanship Manuals. First year:  
(NB =New Book: Level One— pages 7-9, 11, 13-15, Level Three— pages 8-10 and 12-15)  
(OB =Old Book: Level One – pages 3, 7-10, and 15-17. Level Three – pages 8-10 and 12-15.)

25% Part III:   **Grooming/Tacking**  
Member to demonstrate to an Official Judge ability in grooming, saddling and bridling with emphasis given to safety.

25% Part IV:    **Western or English Equitation**  
Judged by the Official Judge

May be ridden either English or Western. The rider shall enter the ring at the walk and wait for acknowledgement from the judge to proceed with the pattern. Upon recognition from the judge, rider shall begin the pattern to the right. Walk from Cone A to B (rider shall stay between the cones while performing the pattern). At cone B, pick up a jog/trot. Jog/trot a full lap of the arena. Halt at cone B. Reverse at the walk and repeat the pattern. Walk from B to A. Jog/trot a full lap of the arena. Halt at cone A and turn and walk to the center of the arena. Halt and back up 3 steps. Upon signal from the judge, the member shall dismount, check their tack (cinch, chinstrap, etc.), present themselves, and then lead their horse from the arena upon dismissal from the judge. (See next page for pattern) If help is needed, member should ask judge or ring steward.

Note: Arena dimensions are approximately 200' x 300'.

Safety shall be considered.

Personal appearance of rider, condition of mount and tack used shall be as set forth in General Rules.

See pages 12 and 16 for appropriate equitation guidelines and pattern.

**TOTAL POSSIBLE SCORE   100%**

Note for leaders and parents: If your child has a reading disability and needs assistance, we can make arrangements to help, i.e.: an oral test. *Please let the 4-H Office know of any special situations prior to July 1st so needs can be met.*

\* For high point, First year horseless member's scores will be included with first year for one horseless/first year high point award.

# Equitation Pattern First Year

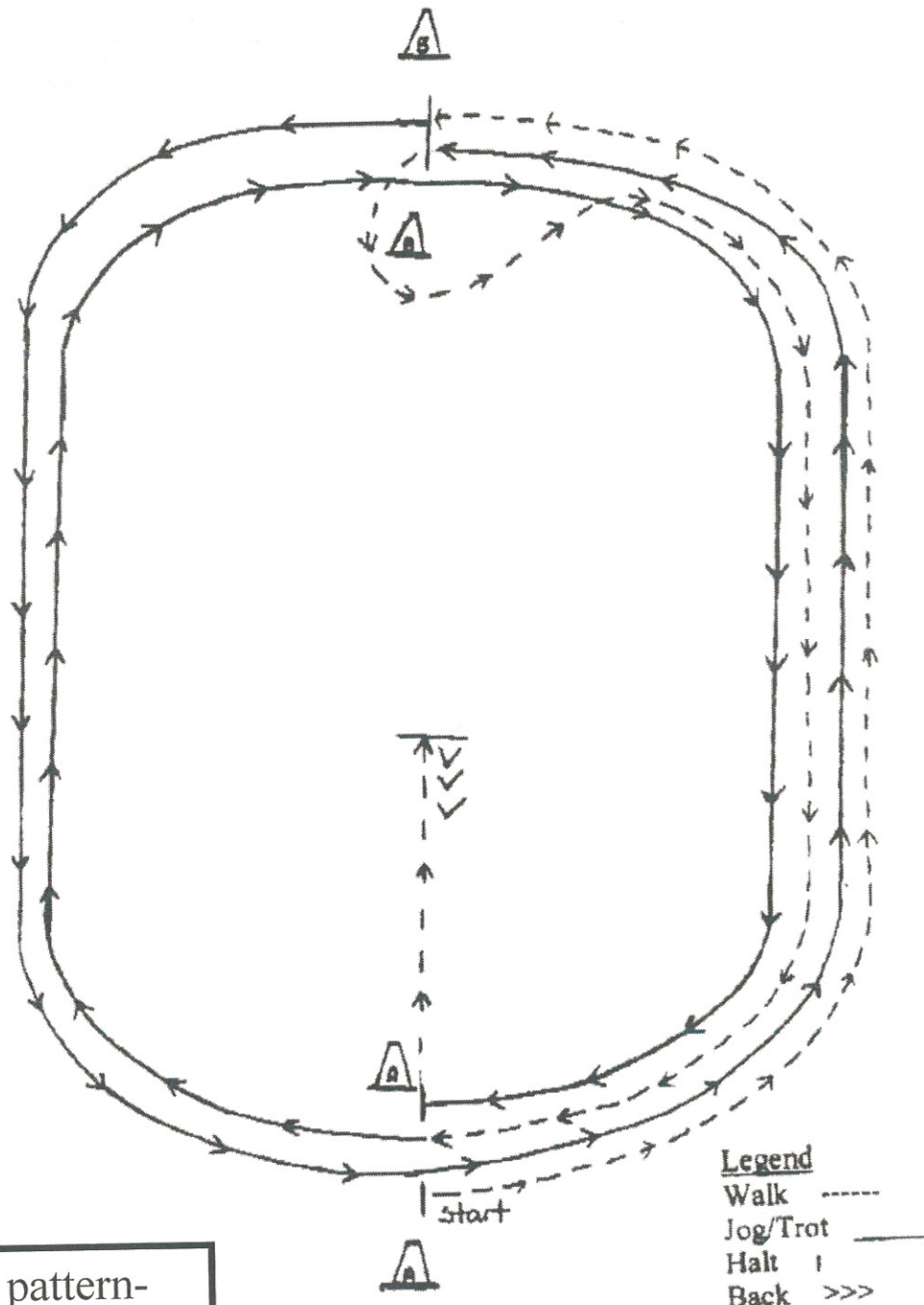

After finishing pattern-dismount, check cinch and chinstrap and then lead your horse out of the arena.

# Second Year Horsemastership Program

25% Part I     **Showmanship Class**  
See pages 4-13 for guidelines.

30% Part II     **Written Test**  
Written program on parts of horse, saddle and bridle, colors and markings, safety when riding, internal and external parasites, diseases and unsoundnesses. Test questions will be taken from CHA Composite Horsemanship Manuals. Second Year:  
(NB =New Book: Level One— pages 13-15, Level Two— pages 5, 8-9, 14-15, 18, 37, Level Four— pages 7, 10, 12)  
(Old Book: Level One – pages 15 and 18, Level Two – pages 5-7, 13-16, and 37, Level Four - pages 8-12.)

20% Part III     **Grab Bag Oral Presentation on a tack item**  
Two minute impromptu grab bag speech on a specified tack item. Member to draw an item out of a “grab bag” and give a 2 minute oral presentation on that tack item. Member will be given 5 minutes to prepare (after all members in the group have drawn an item). Example: Western Curb Bridle (member to include the following points in their presentation) Identify parts, tell how to correctly adjust the bridle on the horse, function or purpose of the tack item, care of the item for cleanliness and safety.

25% Part IV     **Western or English Equitation**  
Horse shall be shown at walk, jog/trot and lope/canter, (always on the correct lead), and back, all at the will of the judge. Rider will show ability to mount and dismount. Safety shall be considered. If help is needed member should ask judge or ring steward for help.

Personal appearance of rider, condition of mount and tack used shall be according to standards as set in the General Rules.

Results as shown by the performance of the horse are not to be considered more important than the method used in obtaining them.

See pages 12 for appropriate equitation guidelines.

**TOTAL POSSIBLE SCORE: 100%**

Note for leaders and parents: If your child has a reading disability and needs assistance, we can make arrangements to help, i.e.: an oral test. *Please let the 4-H Office know of any special situations prior to July 1st so needs can be met.*

# Third Year Horsemastership Program

25% Part I     **Showmanship Class**  
See pages 4-13 for guidelines.

25% Part II     **Written Test**  
Written program on parts of the horse and equipment, age determination, unsoundnesses, color, and markings. Test questions will be taken from CHA Composite Horsemanship Manuals.  
Third Year:  
(NB=New Book: Level One— pages 14-15, Level Two— pages 5, 9-10, Level Four— pages 16, 20-21)  
(OB=Old Book: Level One - pages 16 and 17, Level Two - pages 5-8, Level Four - pages 14 and 18.)

20% Part III     **Judge Halter Class**  
Judge halter class of four horses and give oral reasons.  
10 points for placing the class (using Hormel score cards)  
10 points for oral reasons.

30% Part IV     **Western or English Equitation**  
Horse shall be shown at walk, jog/trot and lope/canter (always on the correct lead), shall back, all at the will of the Judge. Rider shall show ability to mount and dismount. Safety shall be considered.

Personal appearance of rider, condition of mount and tack used shall be according to standards as set in the General Rules.

Results as shown by the performance of the horse are not to be considered more important than the method used in obtaining them.

See page 12 for appropriate equitation guidelines.

**TOTAL POSSIBLE SCORE: 100%**

Note for leaders and parents: If your child has a reading disability and needs assistance, we can make arrangements to help, i.e.: an oral test. *Please let the 4-H Office know of any special situations prior to July 1st so needs can be met.*

# Fourth Year Horsemastership Program

25% Part I **Showmanship Class**  
See pages 4-13 for guidelines.

15% Part II: **Written Test**  
Written program on Western and English Equitation, and general horsemanship. Test questions will be taken from CHA Composite Horsemanship Manuals. Fourth year:  
(NB=New Book: Level One— Page 14-15, 21, 24, 28, 31, Level Two— Page 3, 22, Level Three— Page 22-25, 28-30, Level Four— page 24-25)  
(OB=Old Book: Level One – pages 16-19, and 22-27, Level Two – pages 3, and 20-25, Level Three – pages 29-31, and Level Four -- pages 21-23.)

15% Part III **Judge Halter Class**  
Judge halter class of four horses and give oral reasons.  
5 points for placing the class (using Hormel score cards)  
10 points for oral reasons.

30% Part IV: **Western or English Equitation**  
Horse shall be shown at the walk, jog/trot and lope/canter (always on the correct lead), execute a figure 8, shall back, all at the will of the Judge. Rider will show ability to mount and dismount, safety shall be considered.

Personal appearance of rider, condition of mount and tack used shall be according to standards as set in the General Rules.

Results as shown by the performance of the horse are not to be considered more important than the method used in obtaining them.

See page 12 for appropriate equitation guidelines.

15% Part V **Written Paper**  
A 300 word paper on an equine subject of your choice. **NOTE: Due into the Horsemastership entry coordinator, same date as entry due date, prior to the Horsemastership program.** Papers will be judged on the depth of discussion of the chosen topic and may be either legibly handwritten or typed. Oral Review to be held at the time of judging.

**TOTAL POSSIBLE SCORE: 100%**

Note for leaders and parents: If your child has a reading disability and needs assistance, we can make arrangements to help, i.e.: an oral test. *Please let the 4-H Office know of any special situations prior to July 1st so needs can be met.*

## **New This Year**

**4th year and above— 2:45 pm Riding clinic taught by 7th, 8th and 9th year members**

This is mandatory, but will not be included in your points for Saturday. Please come dressed in your appropriate Western or English riding gear. It will be a fun, learning educational test of your riding skills.

# Fifth Year Horsemastership Program

20% Part I     **Showmanship Class**  
See pages 4-13 for guidelines.

15% Part II     **Written Test**  
Written questions on care and use of equipment and first-aid for horses, general horse care management, and methods of restraint. Test questions will be taken from CHA Composite Horsemanship Manuals. Fifth year:  
(NB=New Book: Level 1— pages 10-11, Level Three— page 19, Level Four— pages 6, 8-9, 12-13, 14-15, 63)  
(OB=Old Book: Level One – page 11, Level Two – page 10, Level Three – page 19, and Level Four -- pages 6 and 7, 10-13, and 60.)

15% Part III     **Judge Equitation Class**  
Member will judge members in the equitation class with the Official Judge. Judge will score 5th year members on how well they judged members in equitation class. Members will give oral reasons. See page 11-12 for appropriate equitation guidelines.  
5 points for placing the class  
10 points for oral reasons

25% Part IV     **Written Paper (please read focus info below thoroughly)**  
A 500 word paper on a Focus Project subject. **NOTE: Due into the Horsemastership entry coordinator, same date as entry due date, prior to the Horsemastership program.** Papers will be judged on the depth of discussion of the chosen topic and may be either legibly handwritten or typed. Oral Review to be held at the time of judging.

25% Part V     **Focus Presentation**  
Member will be asked to demonstrate advanced skills according to their Focus Projects. They will be required to give a fifteen minute maximum presentation of their Focus Project. Presenters should include a three to five minute introduction of their Project and address the audience as well as the judge. No adult involvement will be allowed during the Focus Project presentation. If assistance is needed, members should use another junior member. Judges will ask questions at the end of the presentation.

**TOTAL POSSIBLE SCORE: 100%**

## **Focus Information**

Members may choose any topic relating to horses for their Focus Project. All Focus members will perform the riding pattern on page 22 to demonstrate advanced riding ability even if your focus involves riding. Members will be scored on their performance of this pattern.

**Dress appropriately for selected focus. Focus mandatory for 5th year members.**

Note for leaders and parents: If your child has a reading disability and needs assistance, we can make arrangements to help, i.e.: an oral test. *Please let the 4-H Office know of any special situations prior to July 1st so needs can be met.*

## **New This Year**

**4th year and above—2:45 pm - Riding Clinic Taught by 7th, 8th and 9th year members**

This is mandatory, but will not be included in your points for Saturday. Please come dressed in your appropriate western or English riding gear. It will be a fun, learning, educational test of your riding skills.

# Sixth Year Horsemastership Program

20% Part I     **Showmanship Class**  
See pages 4-13 for guidelines.

15% Part II     **Written Test**  
Written program on feeding, management and training using advanced horsemanship skills, i.e.: leg aids, rein aids, artificial aids. Test questions will be taken from CHA Composite Horsemanship Manuals. Sixth year:  
(NB=New Book: Level Two— pages 3-4, 12-13, 29, 31, Level Three— pages 3-4, 9-10, 12-13, 17, 22-24, 28, Level Four— pages 3-4)  
(OB=Old Book: Level Two – pages 3, 11 and 12, and 31, Level Three – pages 3, 4, 8-10, 12-15, 17, 20-24, 28, and 30, Level Four – pages 3-5.)

15% Part III     **Judge Showmanship Class**  
Judging members in the showmanship class with Official Judge. Judge will score 6th year members on how well they judged members in showmanship class. See pages 5-11 for guidelines. Members to give oral reasons.  
5 points for placing the class  
10 points for oral reasons

25% Part IV     **Written Paper (please read focus info below thoroughly)**  
An 800 word paper on a Focus Project subject. **NOTE: Due into the Horsemastership entry coordinator, same date as entry due date, prior to the Horsemastership program.** Papers will be judged on the depth of discussion of the chosen topic and may be either legibly handwritten or typed. Oral Review to be held at the time of judging.

25% Part V     **Focus Presentation**  
Member will be asked to demonstrate advanced skills according to their Focus Projects. They will be required to give a fifteen minute maximum presentation of their Focus Project. Presenters should include a three to five minute introduction of their Project and address the audience as well as the judge. No adult involvement will be allowed during the Focus Project presentation. If assistance is needed, members should use another junior member. Judges will ask questions at the end of the presentation.

**TOTAL POSSIBLE SCORE: 100%**

## Focus Information

Members may choose any topic relating to horses for their Focus Project. **All Focus members will perform the riding pattern on page 22 to demonstrate advanced riding ability even if your focus involves riding. Members will be scored on their performance of this pattern.**

Note for leaders and parents: If your child has a reading disability and needs assistance, we can make arrangements to help, i.e.: an oral test. *Please let the 4-H Office know of any special situations prior to July 1st so needs can be met.*

## New This Year

**4th year and above—2:45 pm - Riding Clinic Taught by 7th, 8th and 9th year members**

This is mandatory, but will not be included in your points for Saturday. Please come dressed in your appropriate western or English riding gear. It will be a fun, learning, educational test of your riding skills.

# Focus Member Riding Pattern

## RIDING - PATTERN

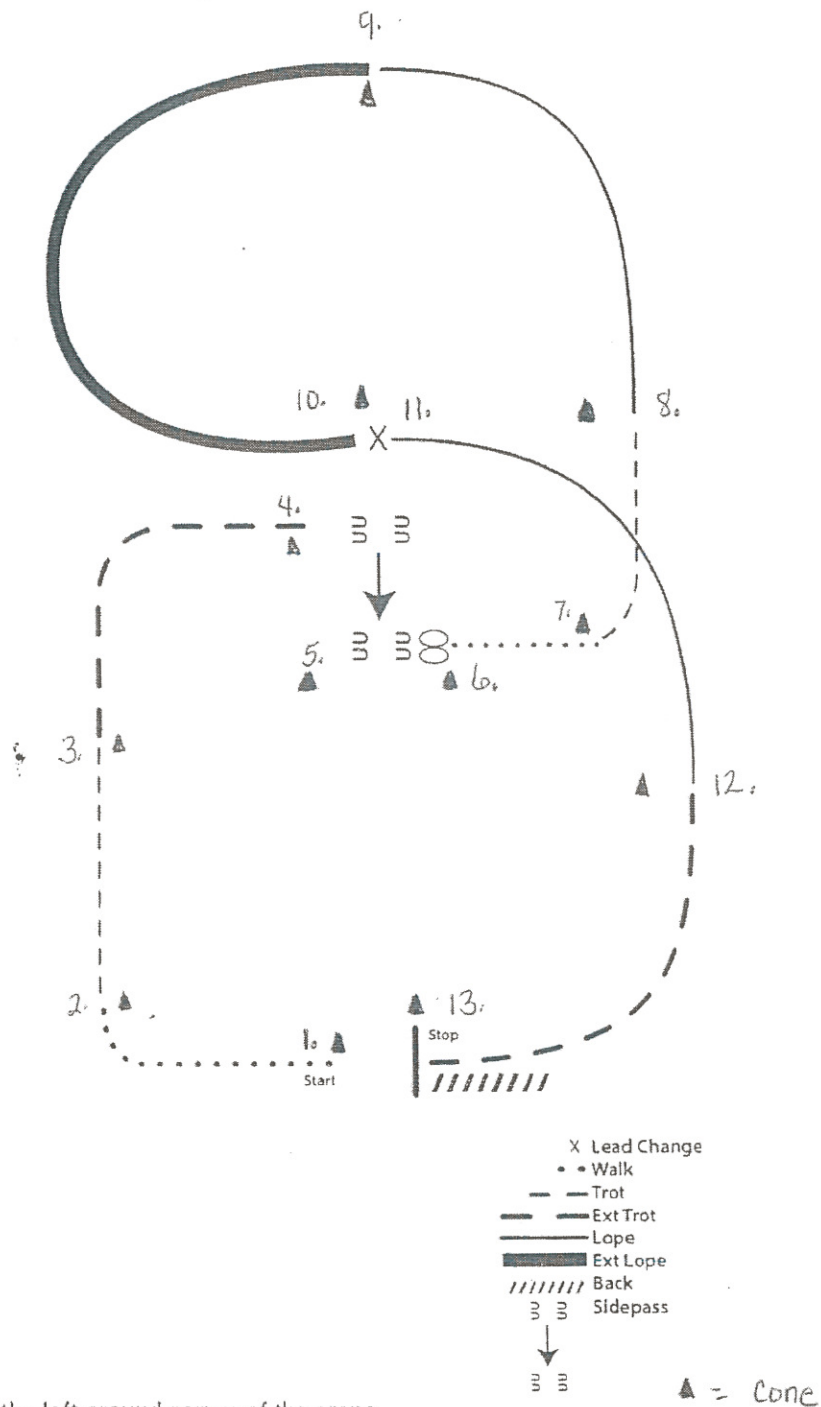

1. Walk to the left around corner of the arena
2. Trot
3. Extend alongside of the arena and around the corner to center
4. Stop, side pass right
5. 360 degree turn each direction (either way 1st)
6. Walk
7. Trot
8. Lope left lead
9. Extend the lope
10. Change leads (simple or flying)
11. Collect to the lope
12. Extend Trot
13. Stop and back

# Seventh, Eighth and Ninth Year Horsemastership Program

## 25% Part I **Written Test**

Written questions on feeding, horse management, parts of foot, normal vital signs, (temperature, respiratory, and pulse heart rate, and trail riding etiquette. Test questions will be taken from CHA Composite Horsemanship Manuals. Seventh year:  
(NB=New Book: Level One—page 34, Level Two—pages 10, 12-13, 37, Level Three—pages 8-10, 48, Level Four—pages 6, 9)  
(OB=Old Book: Level One – page 30, Level Two – pages 8-12, and 37, Level Three – pages 8-10, and 46, Level Four – pages 6 and 10.)

## 25% Part II **Advanced Riding Pattern**

Members will create a riding pattern for themselves from the list of items below. The items marked with a star are mandatory elements that must be included in the pattern. Members may choose as many or all of the rest of the elements. They must draw their pattern on paper and submit these with their entries. Label the patterns to show which elements will be performed. Patterns will be performed before the official judge.

Members will be judged on how well the submitted pattern was performed. Patterns cannot be changed once submitted. Members will receive more points for degree of difficulty in the patterns, as well as for patterns that flow smoothly.

Patterns can be between 3 and 10 minutes in length. Points will be deducted if not within this time frame.

- |                          |  |
|--------------------------|--|
| *1. Walk                 | 9. Roll Back   |
| *2. Trot/Jog             | 10. Slide Stop   |
| *3. Canter/Lope          | 11. Bend in circle   |
| *4. Sidepass             | 12. Two Track  |
| *5. Back                 | 13. Collection and extension in at least one gait                |
| *6. Turn on forehand     | 14. Up to two elements that are not on this list may be included |
| *7. Turn on hindquarters |  |
| 8. Open gate             |  |

## 50% Part III **Plan and Teach a Horsemanship Clinic**

Members will plan in advance a horsemanship clinic for the 4th, 5th and 6th year members. Each member will develop their own topic to be taught. The member will then teach the clinic Saturday afternoon of Horsemanship. A written, detailed plan of your clinic is due with your entry. You may choose a riding or a ground training topic.

The 7th, 8th and 9th year members as a group combined will have two hours to present, teach, and allow younger members to learn and practice the topics they have planned. Plan your clinic to be approximately 15-20 minutes long.

The 7th, 8th and 9th year members will also be helping to guide 1st– 3rd year members on Saturday making sure they understand the flow of the day, and offering to assist where possible.

This part will not count for your Saturday Horsemastership score because you are developing leadership skills and credit for this will be recorded in your regular 4-H record book.

**TOTAL POSSIBLE SCORE: 100%**

Note for leaders and parents: If your child has a reading disability and needs assistance, we can make arrangements to help, i.e.: an oral test. *Please let the 4-H Office know of any special situations prior to July 1st so needs can be met.*

## **Note for Ninth year members**

**In Teaching your horsemanship clinic, more will be expected of you in both the planning and teaching of your clinic– i.e. : level of detail, advanced topic, teaching methods with detailed instruction.**

NEW rules and format this year's Highpoint and  
Reserve Highpoint scoring for  
**Sunday Horse Show**

In an effort to make 4-H members become more all around riders members must participate in the five classes stipulated

1. One Gymkhana class of your choice
2. Trail
3. Western/English horsemanship
4. In hand horse skills pattern
5. Hunter/ranch horse pleasure

The winners will be based on the highest points accumulated in these five classes for Highpoint and the 2nd highest number of points for Reserve Highpoint.

Members who are competing for highpoint may also enter any other classes of their Choice.

If you are not competing for Highpoint you may participate in any number of classes you choose to enter.

# Sunday Horse Show-- General Rules

The two days of Horse Mastership, Saturday and Sunday are two separate events. There is no combined scoring or palcing.

## Members

Participant must be a bona fide 4-H member enrolled in the Plumas and Sierra County 4-H program. Entry forms must be signed by the member's horse project leader and parent or guardian.

**Members must participate in Saturday Horsemastership in order to be eligible for high point awards.**

Members must have control of horses at all times for safety. Riders who cannot control their horses will be disqualified at the discretion of the Horsemastership Committee and/or Judge. This applies to the time the class is called to the time it is dismissed. This is for the safety of all involved. Rider must be mounted.

## Horses

Horses shall be well groomed, feet properly trimmed or shod, sound and healthy. Equipment should be clean and serviceable.

For members participating in both Saturday and Sunday, the same horse must be used on both days, with exception of an *approved* focus horse only. Project members may have more than one project horse but must specify to their leaders and the 4-H Office *prior to May 1st* which horse they will use for Horsemastership/Horse Show. Only one horse shall be used for High Point scores at the Horse Show.

## Other Rules

Decision of the judge is final. Any interference with the judge or un-sportsmanlike display toward him/her or other exhibitors will disqualify the participant.

Parents of the participants shall not, in any way, attempt to influence the judge. Any attempt to do so will disqualify the participant. **NO SWEARING** or profanity by members or parents! Doing so will result in disqualification.

Large classes may be split and an elimination round will be held. Knocking over any obstacle is a 5

second penalty added to your time in all timed events.

Only three attempts will be allowed on each Trail Class obstacle. Going off course or more than three tries is a disqualification.

The trail courses shall be followed as diagramed in this book unless altered by the judge. Official trail diagrams will be posted on Sunday.

Interpretation of the rules of this program will be made by the chairs and co-chairs of the Horsemastership program.

A ring steward will assist the timers.

## Western Dress

Suitable horse show riding clothes consisting of western boots, pants and a long or short sleeved shirt and western belt. **Approved helmets are required for ALL events and when mounted.** Chaps and spurs are optional. Dress not to be considered above general riding abilities.

**\*\* For both the Saturday and Sunday show, short sleeve shirt must be over the shoulder (down the arm). NO SLEEVELESS OR TANK TOPS ALLOWED, except for the gymkhana events on Sunday.**

## Western Tack

Bosal Hackamore, snaffle or other bit are allowed. A smooth, flat, ½ inch chain may be used as a curb strap, but a ½ inch leather curb strap is preferred. Saddle should be of western type, serviceable, and must fit the horse and rider. Spurs, hobbles, rope or rieta are optional. Roping reins are not advisable. A slicker is not required. A riding crop or quirt is permitted in games only if used in a sportsmanlike manner but is not to be used in front of the cinch. Misuse of the crop or quirt will result in a disqualification of the 4-H member. Tie downs, martingales, hackamore bits (mechanical hackamores), and draw reins are prohibited. No cruel or inhumane devices will be permitted. **A safety and equipment check may be made 15 minutes before the equitation class.**

## English Dress

Uniform for members riding English is breeches, English boots, appropriate English attire and helmet. **Approved helmets are required for ALL events and when mounted.** Spurs are optional, but must be of unroweled type.

## English Tack

A snaffle, pelham, or full double bridle is allowed. Curb chains are allowed with pelham bits or double bridles, but not with snaffle bits. Saddles should be of either hunt seat or saddle seat type. A riding crop or quirt is permitted in games only if used in sportsmanlike manner but is not to be used in front of the cinch. Misuse of the crop or quirt will result in a disqualification of the 4-H member. Tie downs, martingales, and draws are prohibited. No bareback pads or riggins are allowed. No cruel or inhumane devices will be permitted. A safety and equipment check *may* be made 15 minutes before the equitation class.

## Scoring

The American System of judging will be used.

There will be four Horse Show groups, relating to the members' experience in Horsemastership.

### 1st year

Beginning/1st year (9-10 years of age as of 1/1/17)

Junior (10 & 12 years of age as of 1/1/17)

Senior (13 years of age and above as of 1/1/17)

### Point system for high point award:

1st: (number of riders in class) + 1

2nd: " " " - 1

3rd: " " " - 2

4th: " " " - 3

5th: " " " - 4

6th: " " " - 5

### Example with 12 riders

1st: 12 + 1 = 13 points

2nd: 12 - 1 = 11 points

3rd: 12 - 1 = 10 points

4th: 12 - 3 = 9 points

5th: 12 - 4 = 8 points

6th: 12 - 5 = 7 points

## Awards

Ribbons (1<sup>st</sup> through 6<sup>th</sup> place) will be awarded for each class. An award will be presented to the high point individual (the rider with the most accumulated points for the day, who also participated in Saturday Horsemastership) in each of the above groups.

In the event of a High Point tie, ties will be broken by throwing out high and low score and averaging the remaining scores. Disqualify or zero is counted as the lowest score.

## Beginning-1st year 9 & 10 (walk/trot ONLY)

No cross entries.

( Any breaking into Lope or canter more than 5 strides is a 5 second penalty. The second break into a lope or canter is another 5 second penalty. The Third break into lope or canter is disqualification.)

## Junior- 10 (with permission of leader) -12 years (walk/trot/lope)

## Senior-13 years and up (walk/trot/lope)

(members may compete in older divisions with permission of horse leader)

## Sunday Horse Show Classes--Judging begins at 8:00 am

Points from classes marked with \* can be counted towards Highpoint.

1. \*Trail-Senior
2. \*Trail-Junior
3. \*Trail-Beginning
4. \*Western/English Horsemanship-Senior (be prepared for rail and individual work)
5. \*Western/English Horsemanship-Junior (be prepared for rail and individual work)
6. \*Western/English Horsemanship-Beginning (be prepared for rail and individual work)
7. \*Hunter/Ranch Horse Pleasure Class-Senior
8. \*Hunter/Ranch Horse Pleasure Class-Junior
9. \*Hunter/Ranch Horse Pleasure Class-Beginning

### Lunch Break

10. \*Cloverleaf barrels-Senior
11. \*Cloverleaf barrels-Junior
12. \*Cloverleaf barrels-Beginning
13. \* Poles-Senior
14. \*Poles-Junior
15. \*Poles-Beginning
16. \*In Hand Horse Skills Pattern-Senior
17. \*In Hand Horse Skills Pattern-Junior
18. \*In Hand Horse Skills Pattern-Beginning
19. \*Big T-Senior
20. \*Big T-Junior
21. \*Big T-Beginning
22. \* Keyhole- Senior
23. \* Keyhole- Junior
24. \* Keyhole—Beginning

All 4-H members are welcome to attend Sunday's Horse Show. Pre-registration is required—must be registered for class at least one class ahead-see show registration booth for entries. Approved helmets are required for all riders.

**Beginning:** 9-10 years, walk/trot only No cross entry into 3-gaited classes. (May register in all Junior classes if leader feels the member is ready.)

**Junior** 10-12

**Senior:** 13 years and up, walk/trot/lope

If a Beginning member wishes to move from the Beginning classes to the Novice Junior classes, they may do so ONLY with the approval of the member's 4-H horse leader. Leader must contact Horsemastership committee prior to submission of entries.

Highpoint awards for Beginning, Junior and Senior will be belt buckles. Only members participating in Saturday's Horsemastership county event will be eligible for Highpoint.

Ribbons will be given to 6<sup>th</sup> place. Post enter classes: must sign up for the class by the end of the previous class (i.e. if you wish to post-enter Senior Poles, you must sign up for the class before the end of Cloverleaf barrels Beginning). Post entry fees are \$5.00. All Highpoint Gymkhana class selection to be done at time of entry.

Western/English Horsemanship will consist of both rail and individual work.

**For more information Contact: Sarah Jackson 249-9343 smj4176@gmail.com, Kristen Dolan 927-9547, Cami Lysen 775-750-0373 Or Donna Matlock 993-1170**

See Horsemastership book for rules.  
JUDGES DECISIONS ARE FINAL

# Horse Show Classes

## **Western Equitation**

See page 12 for description.

## **English Equitation**

See page 13 for description.

## **Western/English Horsemanship**

The judge will ask each rider to work individually on the posted pattern (pages 40-41).

Riders will be judged on seat, hands, ability to control and show horse. Results as shown by performance of the horse are not to be considered more important than the method used by the rider. The horsemanship class is to determine the riding ability of the rider.

Failure to complete the pattern will not be a disqualification but shall be scored accordingly. Two hands on the reins shall be required when the horse is in the hackamore or snaffle bit.

Simple change of lead: This is a change whereby the horse is brought back into walk or jog and restarted into a lope on the opposite lead.

### **Trail**

This class will be judged on the performance of the horse over obstacles, with emphasis on manners, response to the rider, and attitude. Horses should negotiate obstacles willingly and carefully. Final trail patterns may be changed at the judge's discretion—final patterns will be posted Sunday morning by 7:30 am.

### **Western/English Horsemanship**

The horse and rider pair will be judged on both the rail and on individual work as indicated by the judge, while exhibiting poise and confidence and maintaining a balanced, functional, and correct body position. Horse and rider should work in complete unison, executing each maneuver with subtle aids and cues.

### **In hand horse skills pattern**

See the pattern on page 32-34.

### **Barrel Racing (Cloverleaf)**

This is a timed event. See the pattern on page 31.

### **Poles**

This is a timed event. See pattern on page 35.

### **Keyhole**

This is a timed event. See the pattern on page 36.

### **Big T**

This is a timed event. See the pattern on page 37

### **Western Equitation**

See page 12 for a description.

### **English Equitation**

See page 13 for a description.

### **Hunter / Ranch Horse Pleasure Class**

#### **Hunter Pleasure (english tack)**

Hunter pleasure classes are judged on manners, obedience, consistency, and movement, in that order. This horse should look like the kind of horse you could trust to go riding in the worst windstorm and he would continue on his merry way without a hitch.

This class should be ridden on either a soft contact or loose rein. The horse should be forward moving, and simulate riding outside the confines of an arena as if on a pleasurable hack through the countryside. Flashy moving horses are not rewarded over well trained, solid, consistent moving horses. The overall manners and responsiveness of the horse while performing the maneuver re-

quirements, and the horse's quality of movement are the primary considerations.

### **Ranch Horse Pleasure (western tack)**

The purpose of Ranch Horse Pleasure horse should reflect the versatility, attitude, and movement of a working horse.

The horse's performance should simulate a horse riding outside the confines of an arena and that of a working ranch horse. This class should show the horse's ability to work at a forward, working speed while under control by the rider. Light contact should be rewarded and horse does not have to be shown on a full drape of reins. The overall manners and responsiveness of the horse while performing the maneuver requirements, and the horse's quality of movement are the primary considerations.

### **Required Movements:**

Walk

Trot / Jog

Canter / Lope

Stop / Back / Change Direction

Extended Trot / Jog

Hand Gallop / Extended Lope (junior and senior classes)

2 Ground Poles (beginner classes)

2 Cross Rails (junior and senior classes)

This class will be held by age group on the rail. For English riders the extended trot may be posted or may be ridden at the two-point position. For Western riders the extended jog may be posted or may be ridden standing. At the end of the rail work the judge will call for the riders to line up in the arena. One rider/horse at a time will be directed to complete the ground poles / cross rails. For beginner riders the ground poles may be completed at a walk or trot/jog (rider preference). For junior and senior riders the cross rails may be completed at a trot/jog or canter/lope (rider preference). The ground poles / cross rails will be judged on the **horse's willingness** to safely and effectively cross the obstacles. Horses that evade, knock over, or refuse the obstacles will have points deducted.

## CLOVERLEAF BARRELS

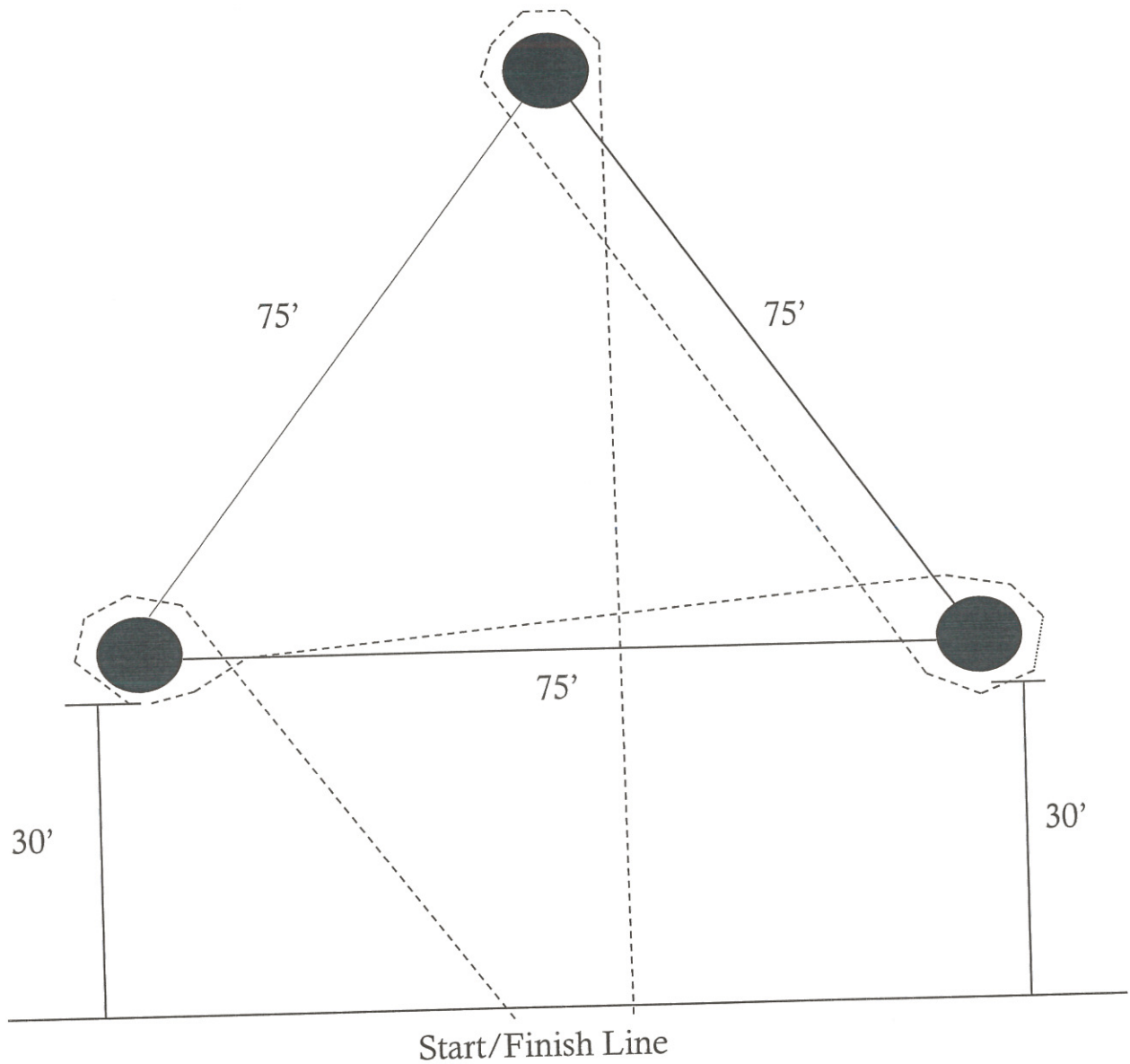

Must complete pattern as shown. Rider can start either the right or left barrel on the first. Rider must cross the finish between the pole markers. Faster times, better places.

Knocking over a barrel incurs a time penalty of 5 seconds.  
Going off course is a no time.

# In Hand Horse Skills Pattern

## **In Hand Skills**

The in hand skills class is designed to demonstrate the ability to control your horse on the ground. It is not a showmanship class. It is judged on the ability to perform the specified maneuvers with emphasis on manners, response to the handler and attitude of the horse.

### **In-hand skills pattern**

#### **Beginner**

Start at A. Acknowledge judge.

Walk to B. Stop. Perform a 360 degree turn to the right.

Approach C, turn your horse around and back through the cones.

When finished backing, do a 180 degree turn on the backhand, turning to the right.

Walk to D and trot the triangle, stopping at D when finished.

Approach E. Send your horse in a half circle as if lunging, at a walk or trot either direction. Pressure from a lead rope or ground training stick is allowed (no contact from the rope or stick).

Acknowledge judge and exit arena.

### **In-hand skills pattern**

#### **Junior/Senior**

Start at A. Acknowledge judge.

Walk to B. Stop. Perform a 360 degree turn on the **forehand** (either direction).

Handler can use slight hand pressure, or pressure from lead rope (swinging) or ground training stick/dressage whip (no contact from the rope or stick).

Approach C, turn your horse around and back through cones.

When finished backing, do a 180 degree turn on the backhand, turning to the right.

Walk to D and trot the triangle, stopping at D when finished.

Approach E. Send your horse in a half circle to the left through the cones as if lunging, at either the walk or the trot. Change direction either by stopping and turning your horse, or with your horse turning in continuous motion.

Both methods are acceptable. Repeat sending your horse through the cones in a half circle to the right. Again, pressure from a lead rope or ground training stick is allowed (no contact from the rope or stick).

Acknowledge judge and exit arena.

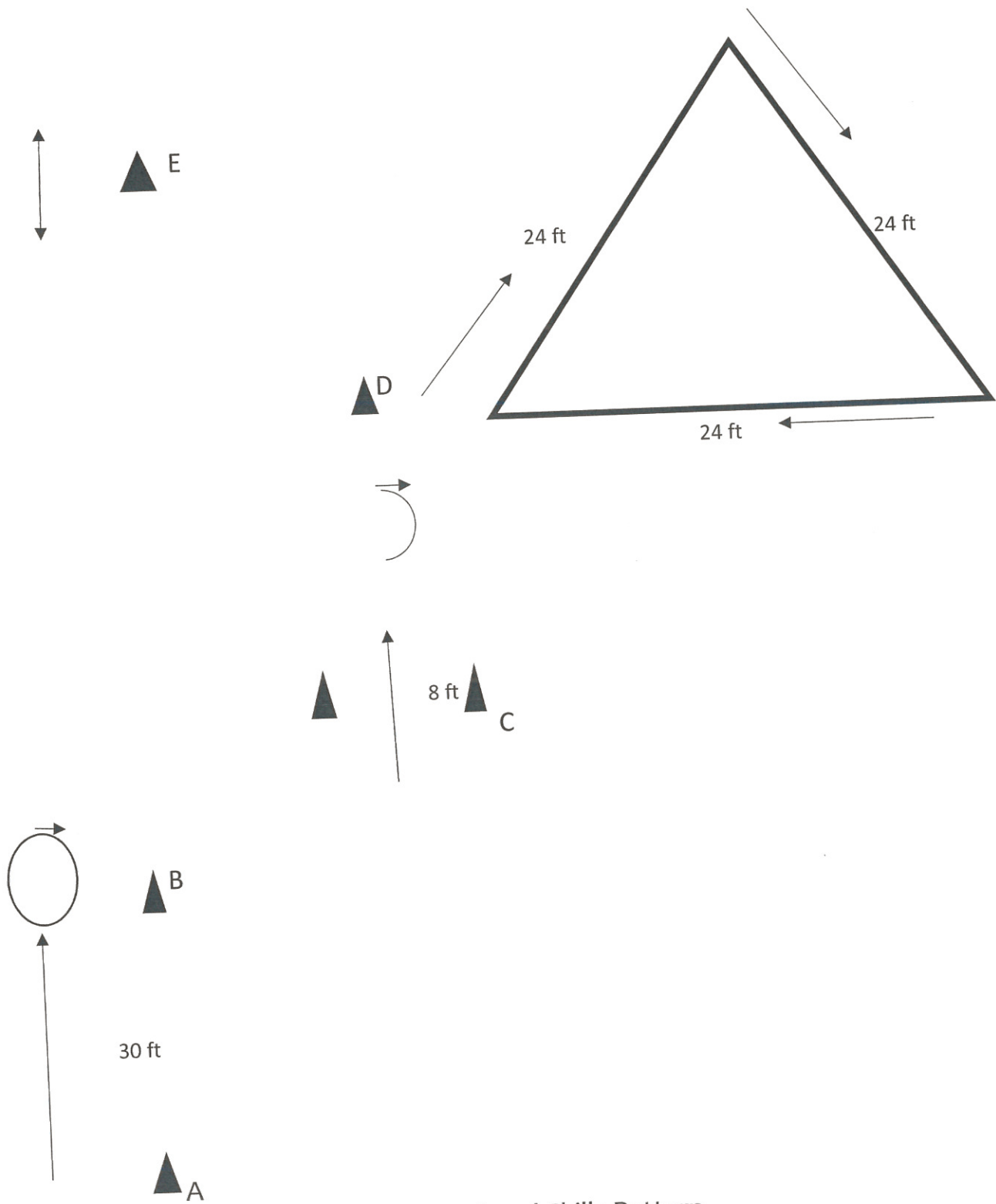

In-hand Skills Pattern  
Beginner

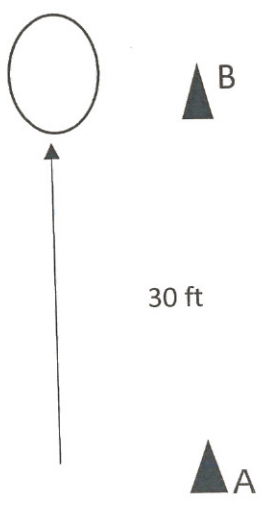
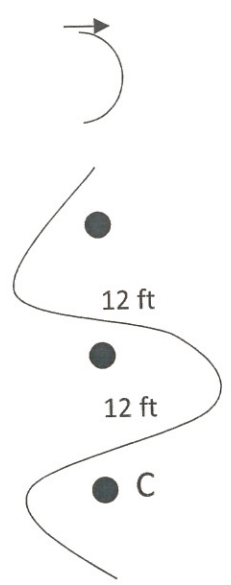
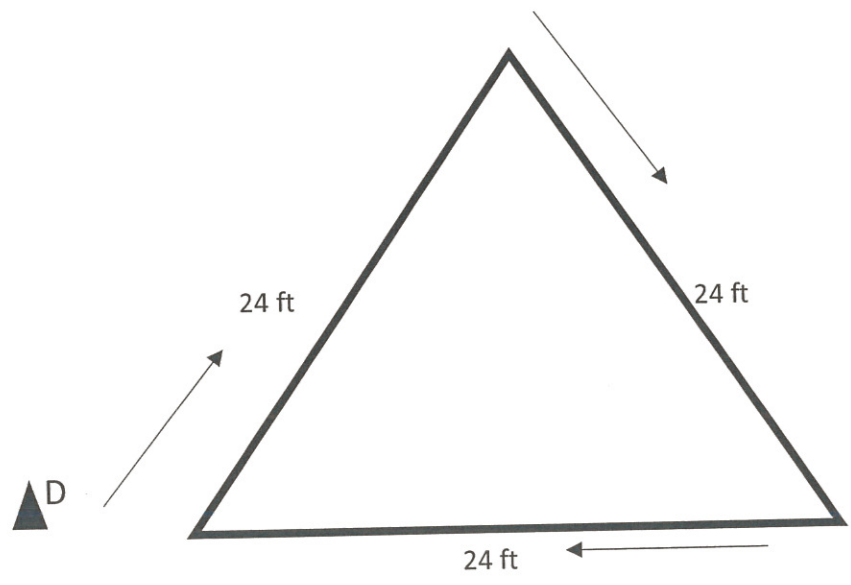
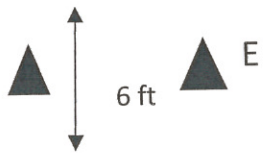

In-hand Skills Pattern  
Junior/Senior

# Poles

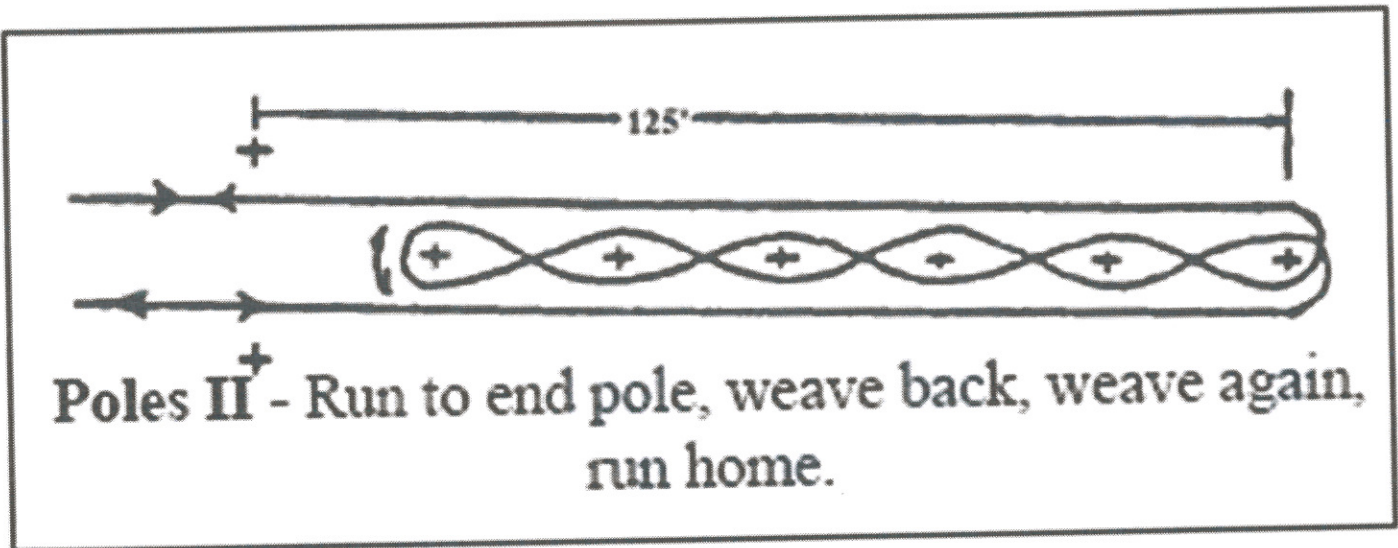

21 feet between poles  
80 feet to starting line  
30 feet between starting markers

# KEYHOLE

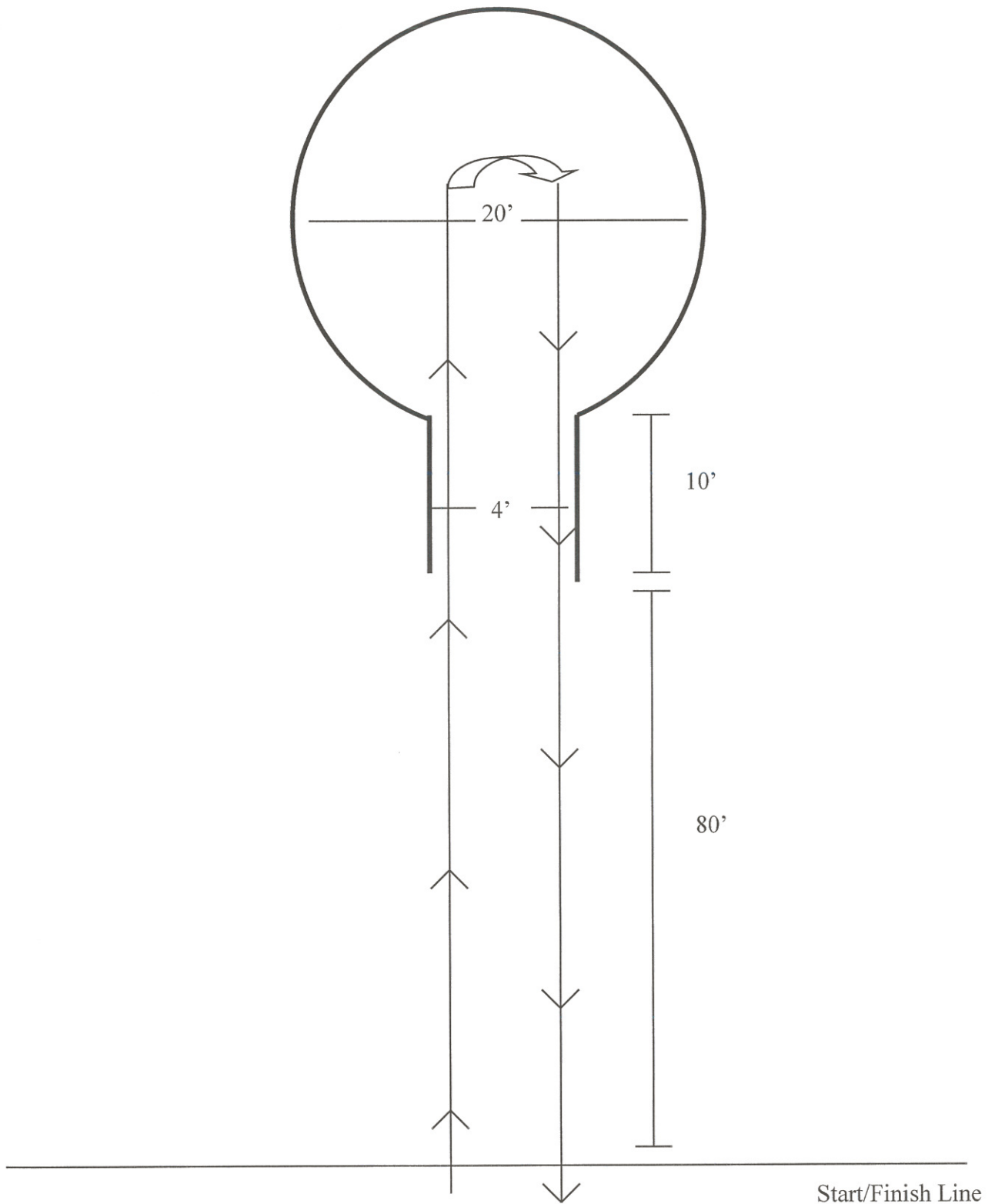

This is a timed event: Run or trot your horse to the keyhole marked in flour, stop, turn or pivot your horse 180 degrees without touching the white lines. Leave the same way you came in. Run past the finish line. Faster times, better placing. If horse touches or steps on white line, 5 second penalty. If horse steps over white line, no time.

# BIG T

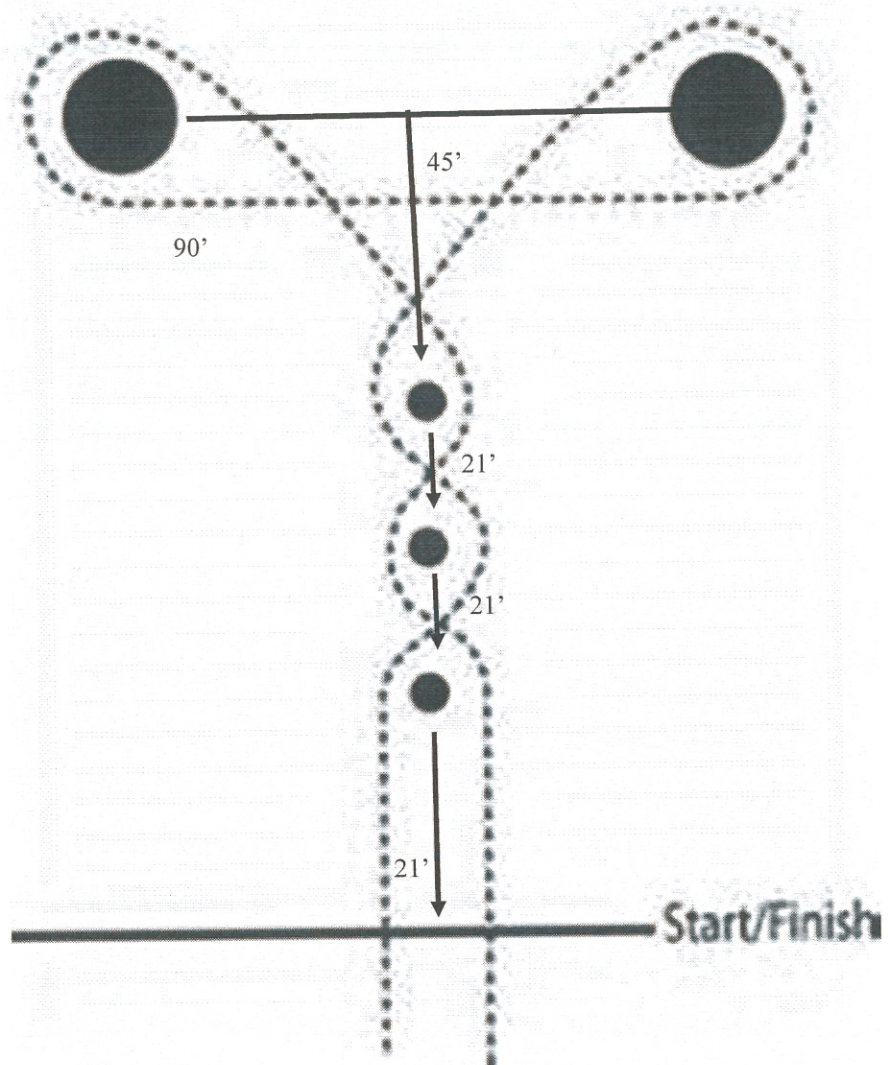

Left or right hand pattern may be used. Two large barrels and three standard size poles are to be used.

# BEGINNING TRAIL COURSE

This is a sample pattern only. Obstacles and their location may vary at the judges discretion.  
Final patterns will be posted by 7:30 am Sunday morning.

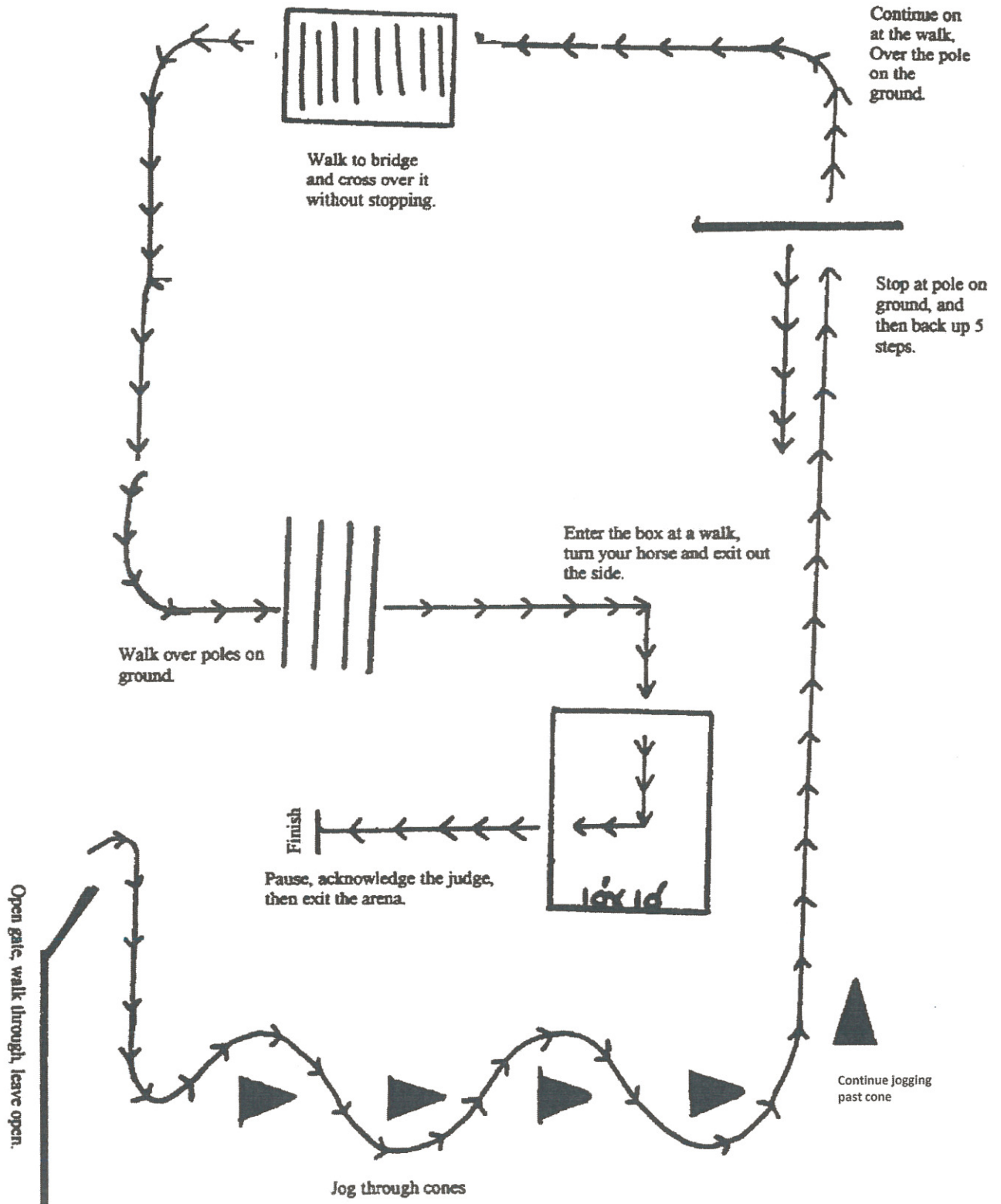

NOTE: Changes may be made to course pattern due to area constraints, at the discretion of the judge.  
Final patterns will be posted before the class begins.

# JUNIOR TRAIL COURSE

This is a sample pattern only. Obstacles and their location may vary at the judges discretion.  
Final patterns will be posted by 7:30 am Sunday morning.

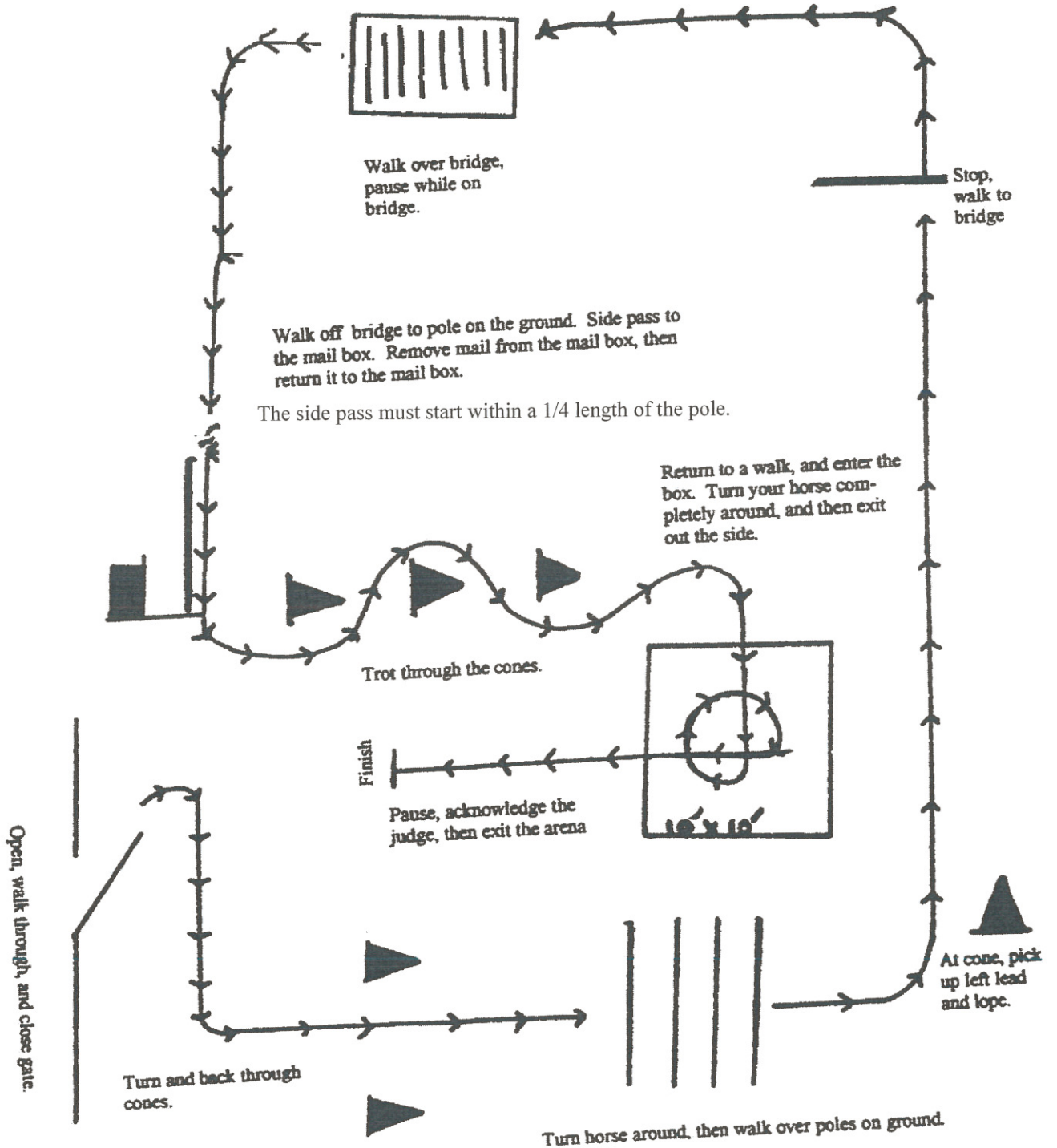

NOTE: Changes may be made to course pattern due to area constraints, at the discretion of the judge.  
Final patterns will be posted before the class begins.

# SENIOR TRAIL COURSE

This is a sample pattern only. Obstacles and their location may vary at the judges discretion.  
Final patterns will be posted by 7:30 am Sunday morning.

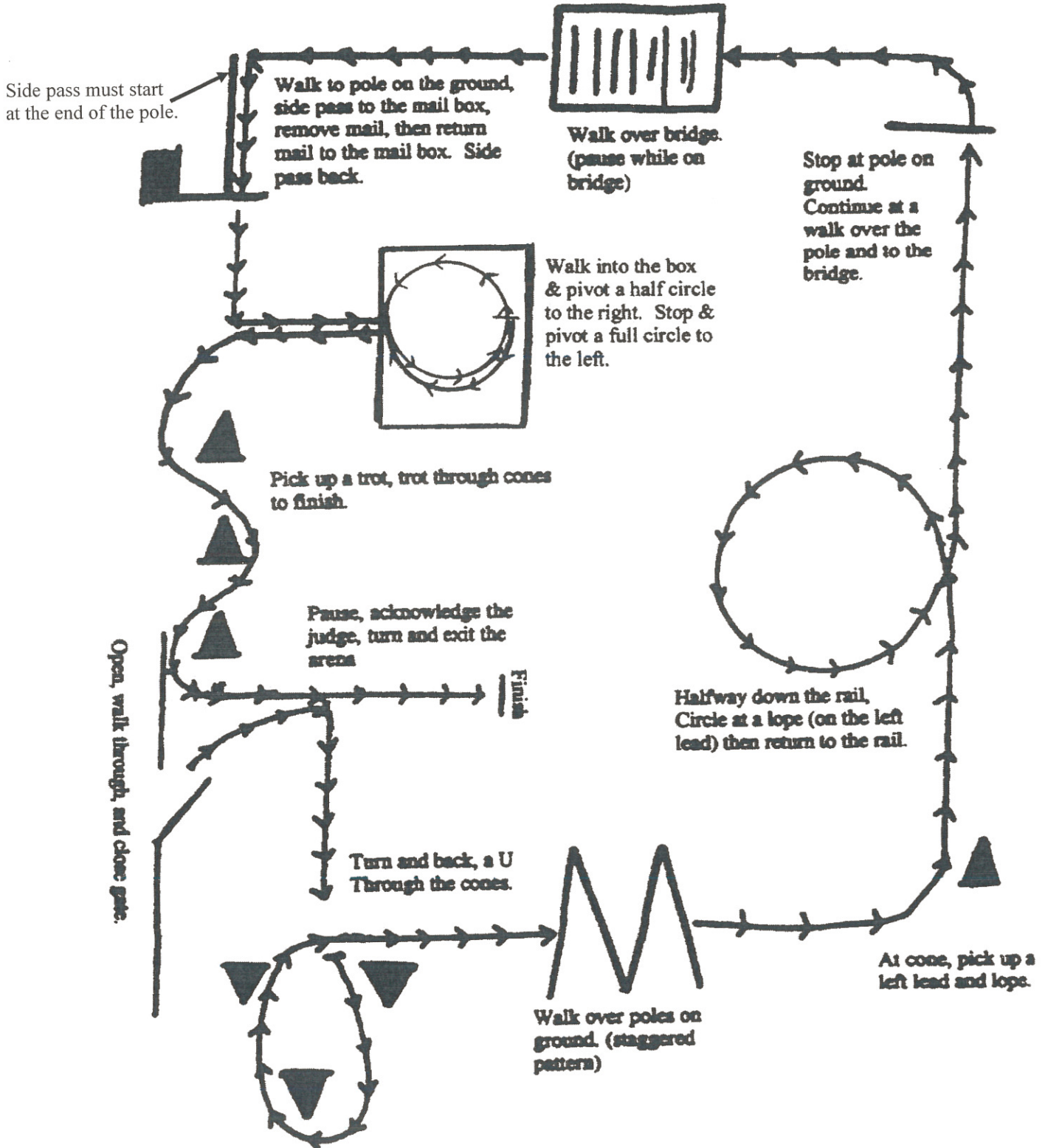

NOTE: Changes may be made to course pattern due to area constraints, at the discretion of the judge.  
Final patterns will be posted before the class begins.



# JUNIOR & SENIOR WESTERN ENGLISH HORSEMANSHIP PATTERN

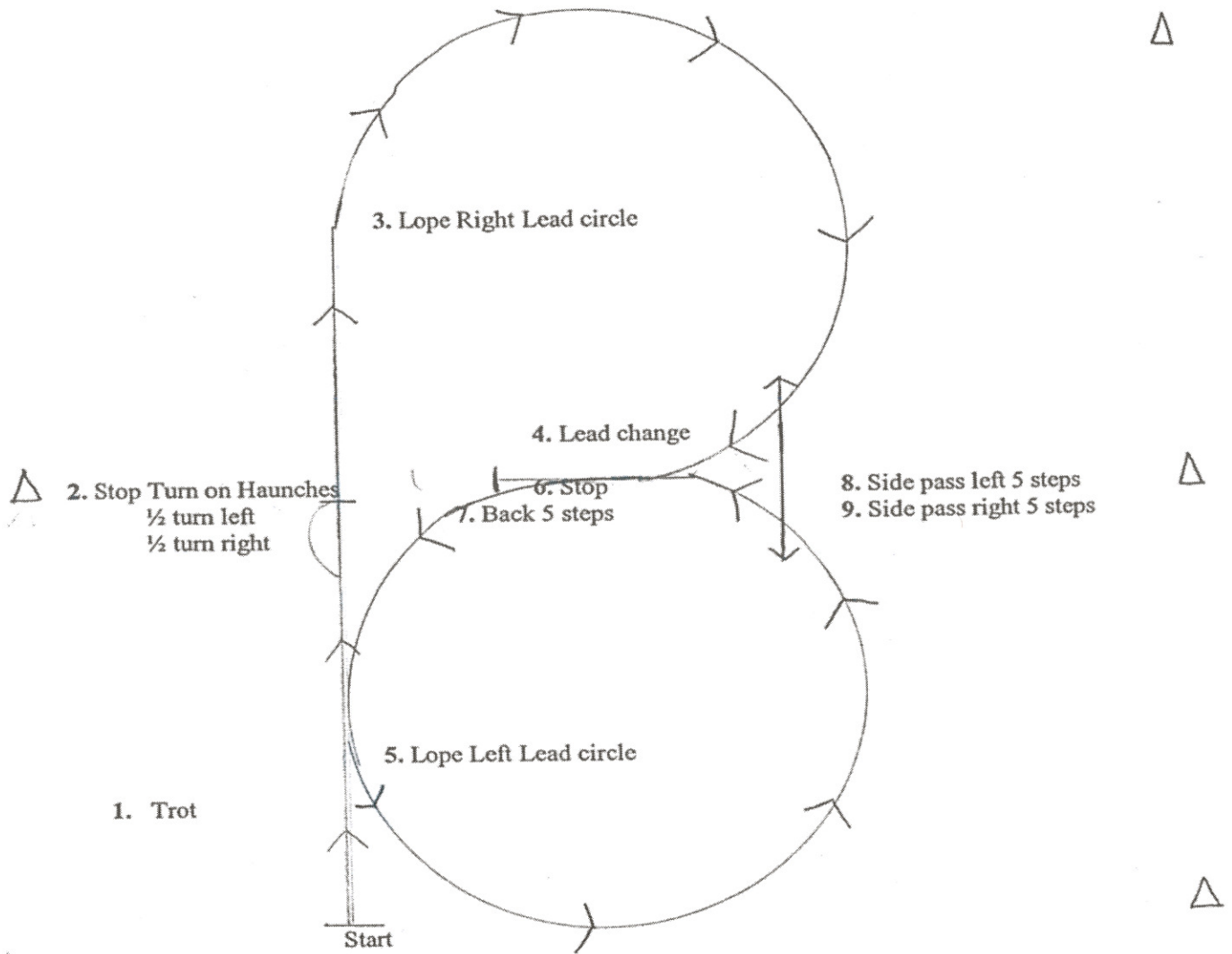

## Junior, Intermediate and Senior Western and English Horsemanship Pattern

Junior and Intermediate— simple lead change  
 Senior— Flying lead change

# BEGINNING WESTERN ENGLISH HORSEMANSHIP PATTERN

