

Biofuels

Woody Biomass to Energy Workshop

September 14, 2010

UC Cooperative Extension

Oroville, California

Rob Williams

Biological and Agricultural Engineering

California Biomass Collaborative

University of California, Davis



Contents

- Overview of Biofuel Pathways
- Starch to Ethanol (conventional ethanol)
- Conventional Biodiesel
- Cellulosic Ethanol
- Thermochemical Biofuel Pathways
 - Renewable diesel and hydrocarbons
 - Renewable synthetic natural gas
- Greenhouse Gas Emissions
- Costs

Biofuel Pathways

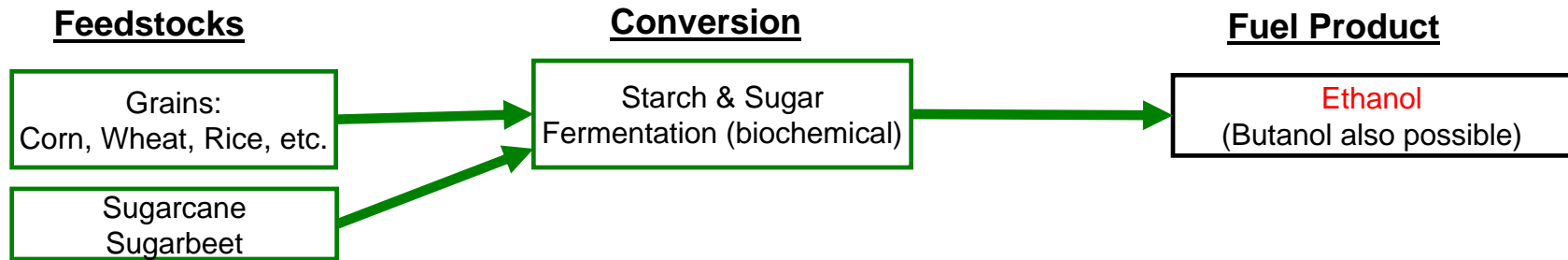

Biofuel Pathways

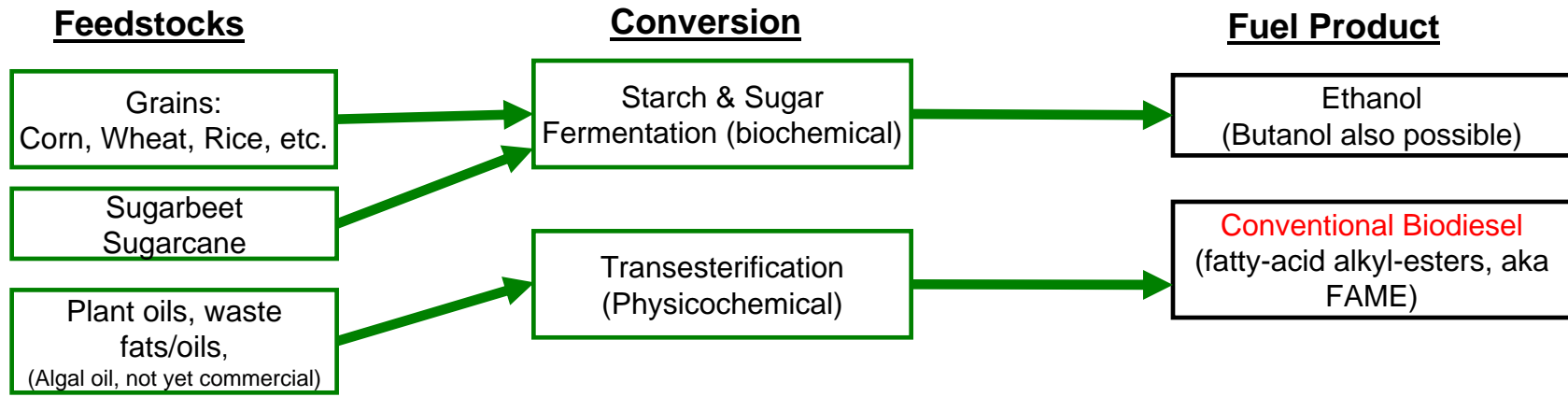

Biofuel Pathways

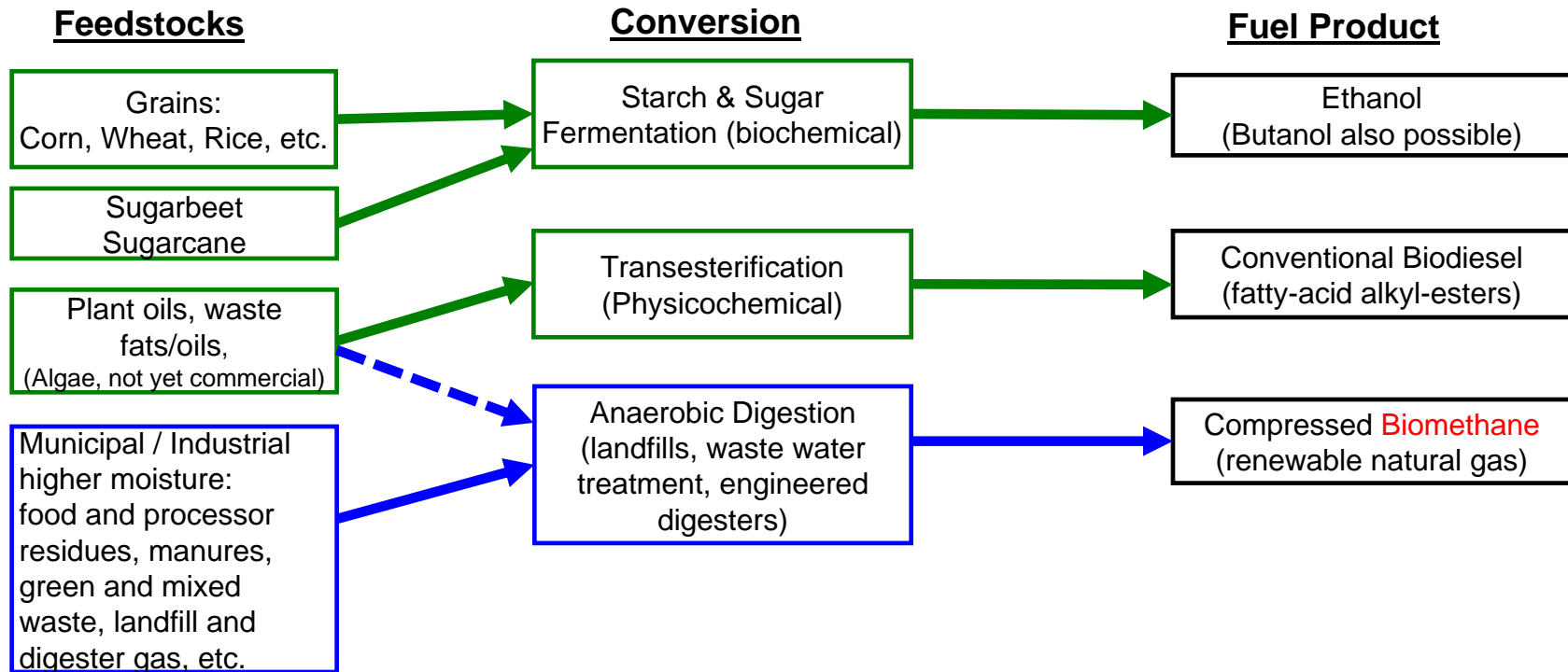

Biofuel Pathways

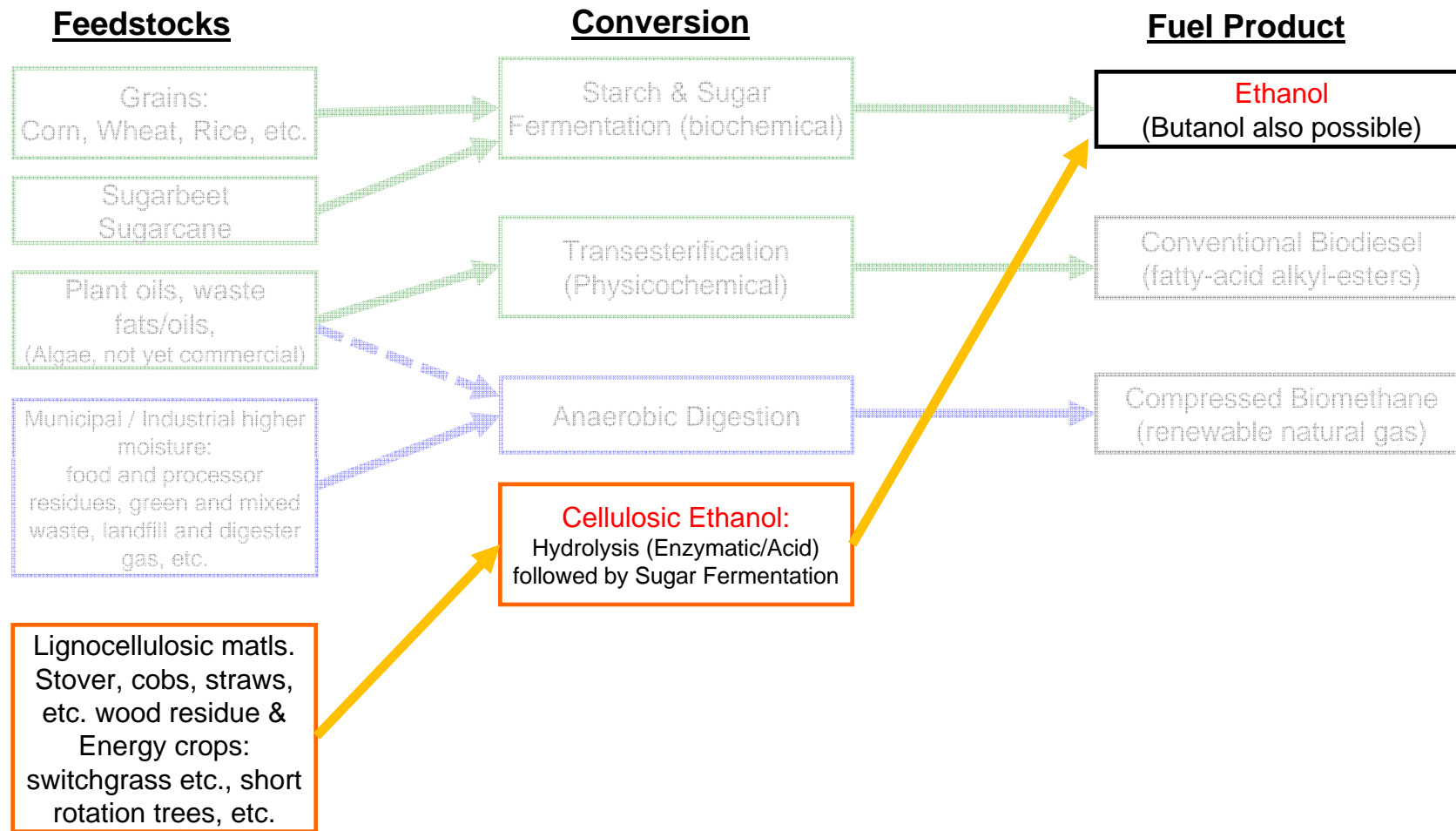

Biofuel Pathways

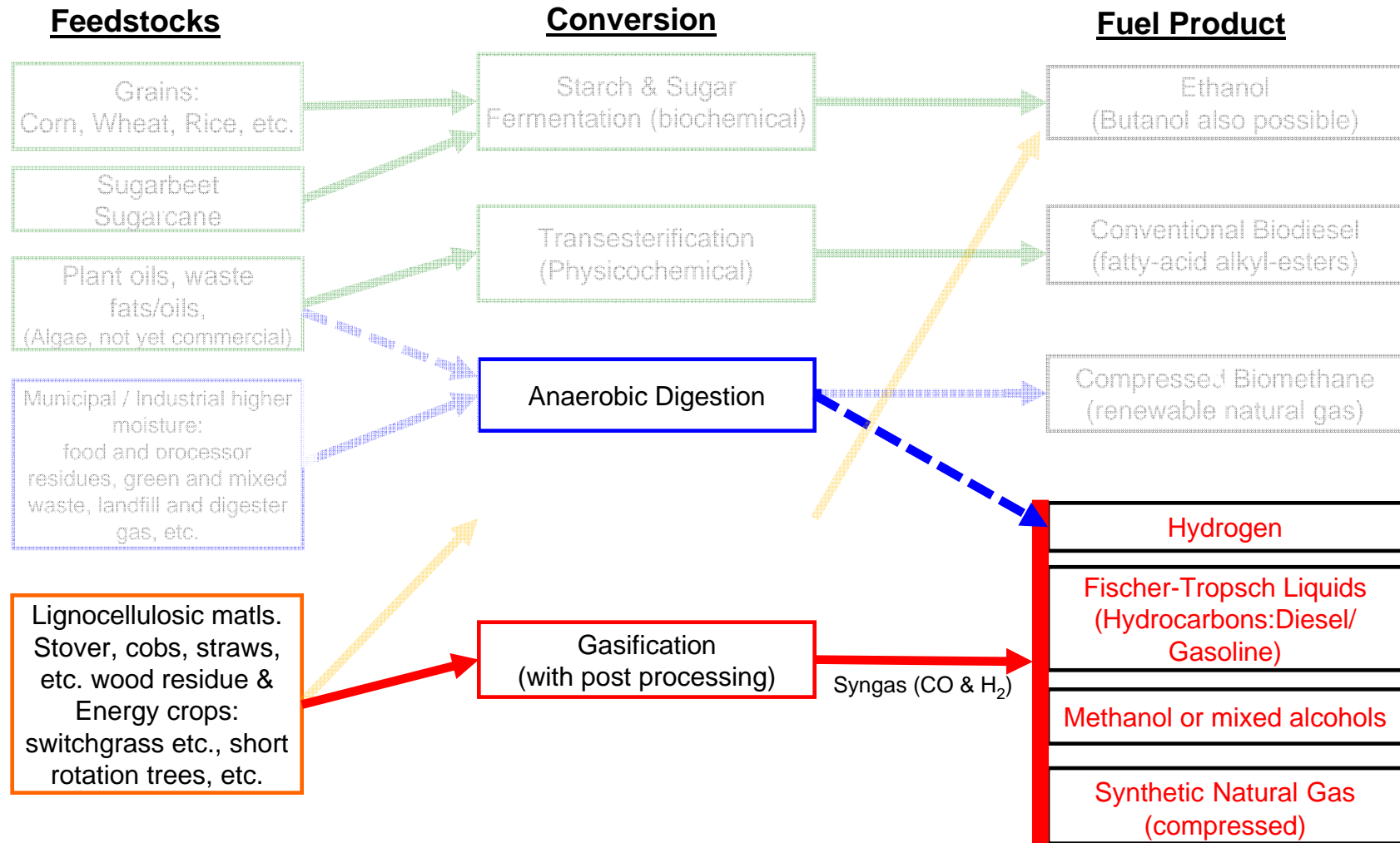

Biofuel Pathways

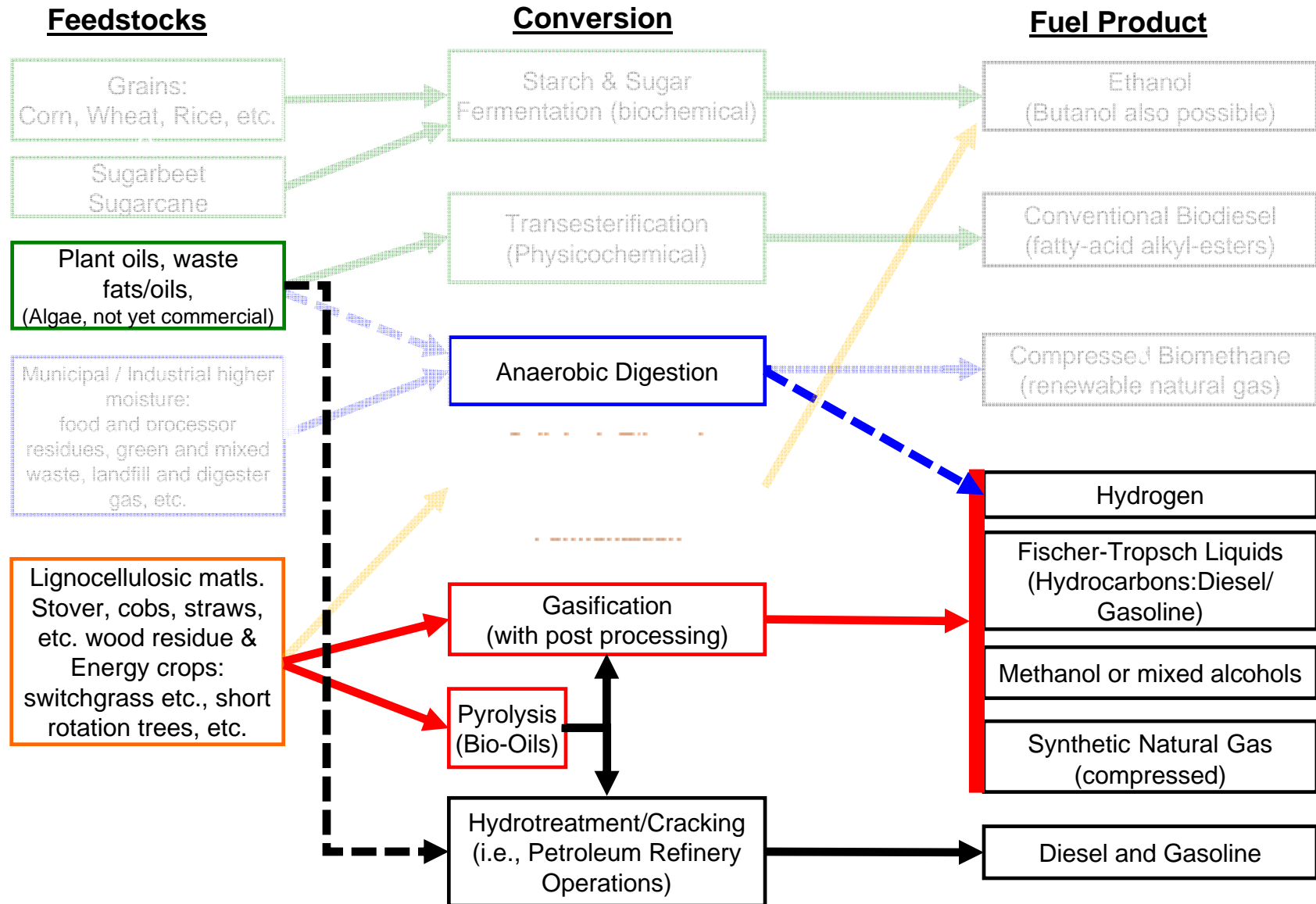

Biofuel Pathways

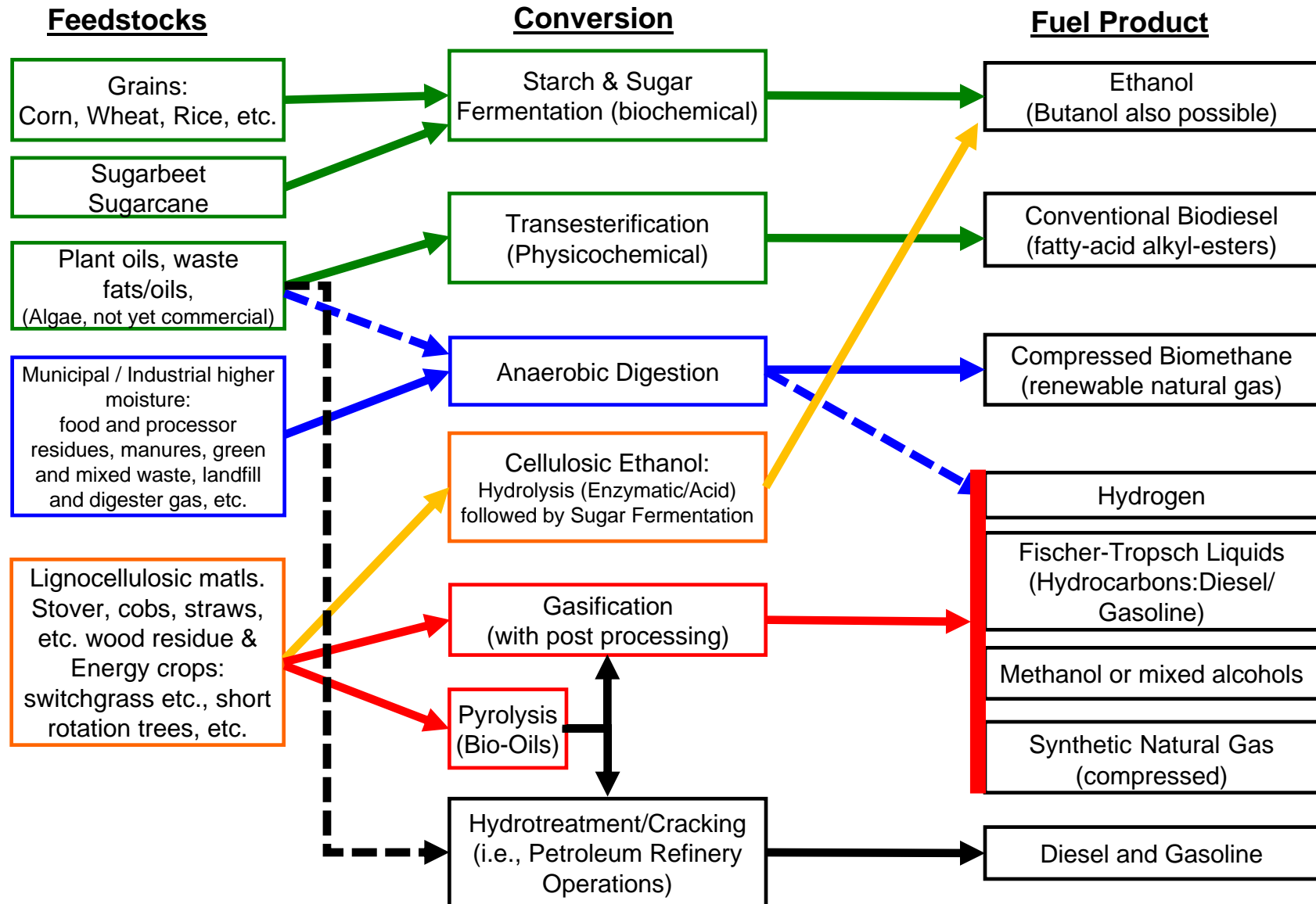

Ethanol Fermentation: Starch/Sugars

- Well known technology (glucose fermentation)
- Basis for corn grain-ethanol industry
- Sugar feedstocks similarly fermented (e.g. sugar from sugar cane in Brazil, sugarbeets possible)
- Efficiency improvements continuing
- Uncertainties regarding sustainability (Carbon charge from indirect land use effect (ILU) for California Low Carbon Fuel Standard (LCFS) is large: **Corn EtOH is ~ same as gasoline for lifecycle greenhouse gas emissions**)
- Ethanol is not fungible with petroleum distribution – pipelines

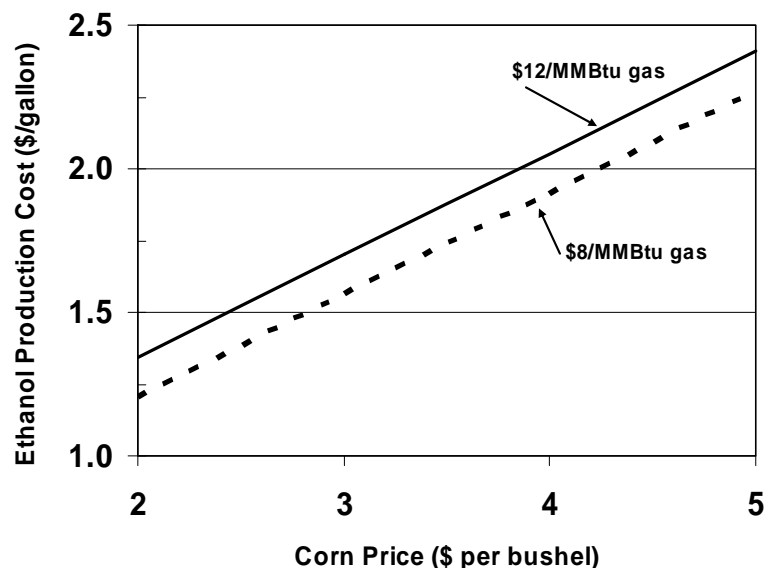

Photo; B.M. Jenkins

Conventional Biodiesel

- Mono-alkyl esters of fatty acids derived from plant oils and animal fats.
- Sometimes called FAME (for fatty-acid-methylester)
 - Fatty acid ethylester (FAEE)
- Some potential for cold weather flow ability problems
- Can have oxygen stability problems (shorter shelf life)
- Production to ASTM standards important – Engine OEMs hesitant to warranty due to off-spec product in the market.
- Considered Commercial Process but product is not fungible with current petroleum pipeline distribution system
- Many oil companies not interested in biodiesel- - want a hydrocarbon product from biomass that can be mixed / produced at the refinery and distributed w/ fossil products (engine OEMs would be happier too)

Cellulosic Ethanol

Fermentation Using Lignocellulosic Feedstocks

- Cellulose, hemicellulose is the feedstock
- Bound by lignin – tough to get at – and lignin passes through process as a residue
- Needs Pretreatment and Hydrolysis (cellulose depolymerization--glucose release) to get to sugar molecules
- Opportunity to use
 - the whole plant (corn + stover)
 - Non-food 'energy' crops
 - Biomass residue (large potential amount) for biofuel production
- Should have improved lifecycle greenhouse gas performance compared to starch/sugar-to-ethanol
- Improved per acre biofuel yield for case of energy crops (sustainability issues need to be understood).

Not yet (again) commercial

- Acid hydrolysis of wood one of earliest technologies for fuel/industrial ethanol (WW I)
- US DOE, NREL, Novozymes, Genencor work on cellulase enzymes (enzymatic hydrolysis)
- DOE has awarded \$\$ to multiple cellulose to ethanol demonstrations ("Commercial Scale")
- Much entrepreneurial interest and venture capital

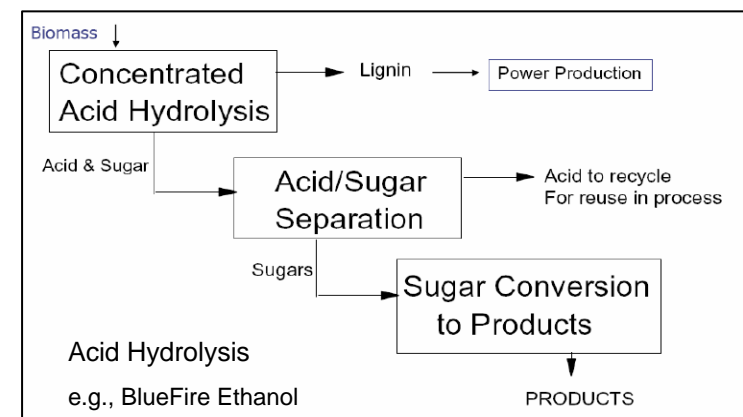
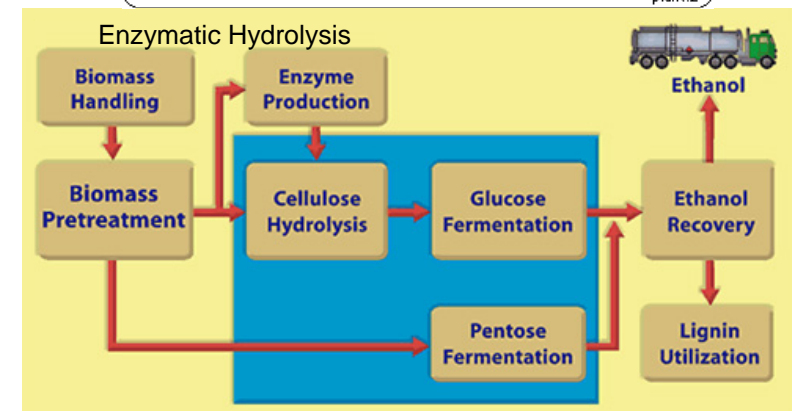
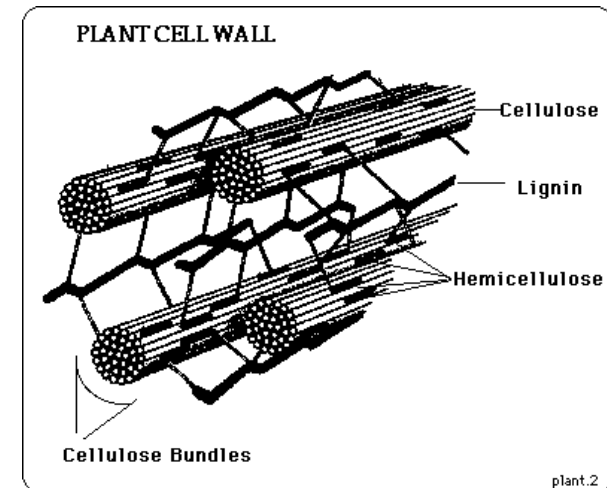

Renewable Diesel or Renewable Synthetic Diesels include

(these are the hydrocarbon liquids oil companies are looking for):

- “Drop-in” Fuels or hydrocarbons (compatible with distribution and current engines)
- Fischer-Tropsch diesels from gasified biomass (syngas : CO and H₂)
 - FT diesels sulfur free
 - Wide product spectrum including gasolines, diesels, alcohols, waxes, aviation fuels, higher value consumer products
 - Yields expected to be 60 -80 gallons liquid hydrocarbon product per dry ton biomass
- Hydrotreatment, is hydrothermal upgrading of vegetable oils and animal fats, other lipids and esters (e.g. Shell, Neste, Petrobras, UOP) as well as Bio-oils from fast pyrolysis
- Low life-cycle greenhouse gas footprints
- Capital intensive
 - Desire large plant for economies of scale
 - Therefore requires large flow of feedstock

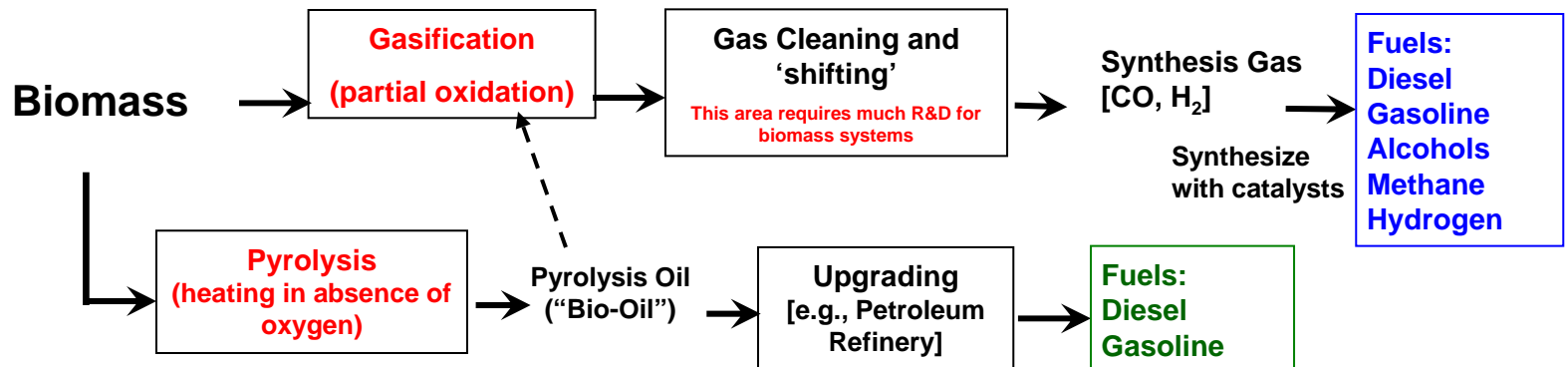

Synthetic Natural Gas (SNG) from thermal gasification of biomass:

Recent awards from the Energy Commission
(Alternative and Renewable Fuel and Vehicle Technology Program)

Harvest Power / Agnion / City of San Jose
"Urban wood waste to biomethane"
(San Jose)

\$1.9 million award



G4 Insights Inc.

"Forest biomass conversion to compressed biomethane"
(Placer County?)

\$1.2 million award

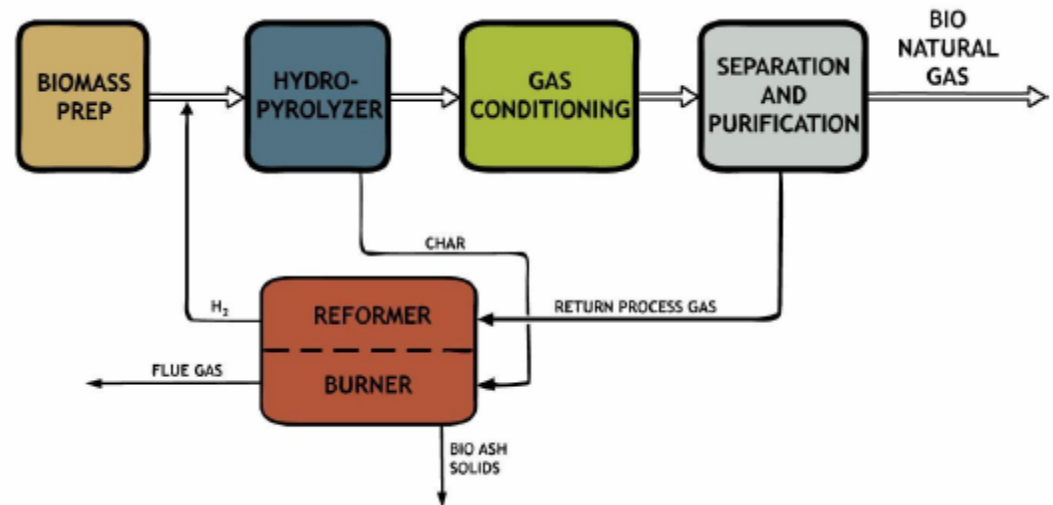

Relative Greenhouse Gas Emissions of Alt. Fuels compared to conventional gasoline/diesel

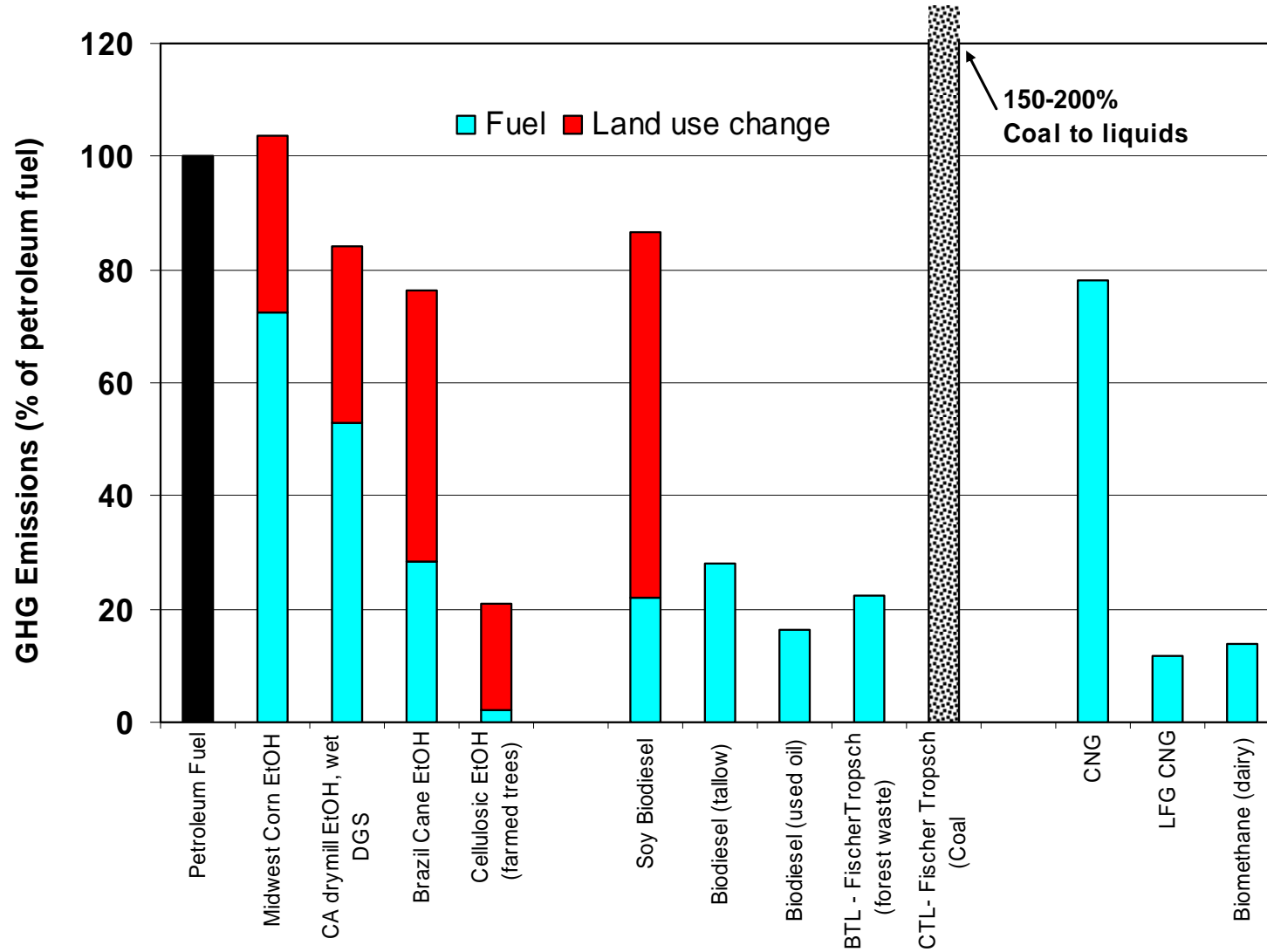

California Air Resources Board – LCFS various reports- see: <http://www.arb.ca.gov/fuels/lcfs/lcfs.htm>

WELL-TO-WHEELS ANALYSIS OF FUTURE AUTOMOTIVE FUELS AND POWERTRAINS IN THE EUROPEAN CONTEXT http://ies.jrc.ec.eu.int/media/scripts/getfile.php?file=fileadmin/H04/Well_to_Wheels/WTTWTT_Report_030506.pdf



DOE production cost goals Ethanol prices and

DOE Cellulosic Ethanol Cost Targets (\$/gallon of ethanol)

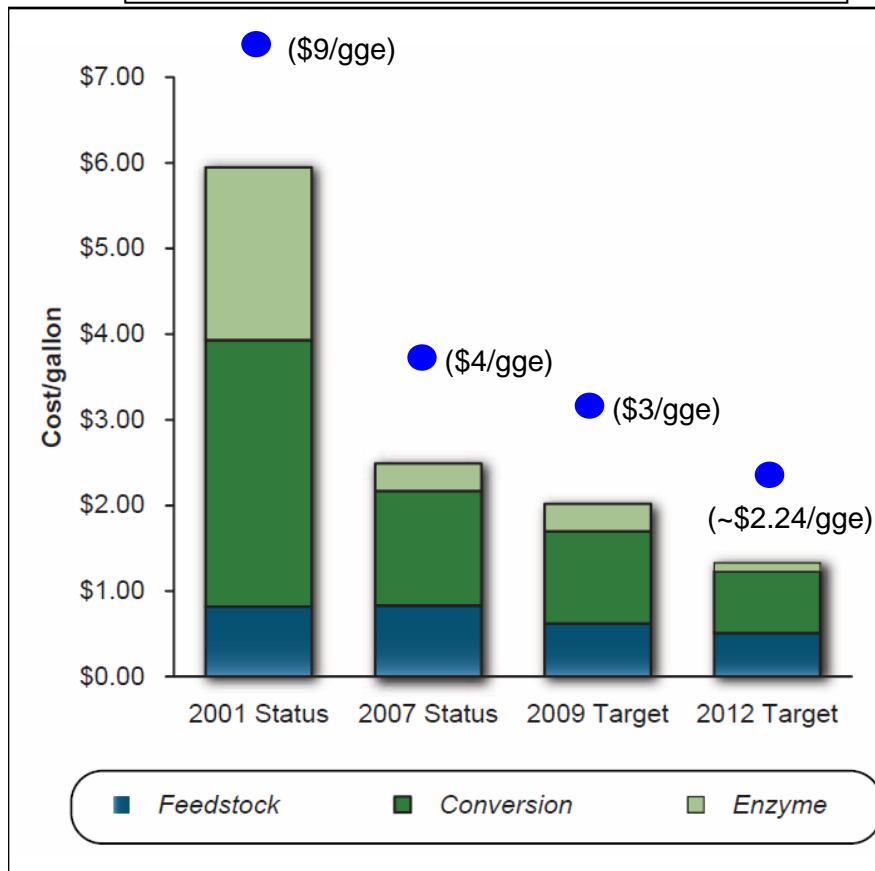

Source: DOE EERE Office of the Biomass Program, Multi-year Program Plan, App. C

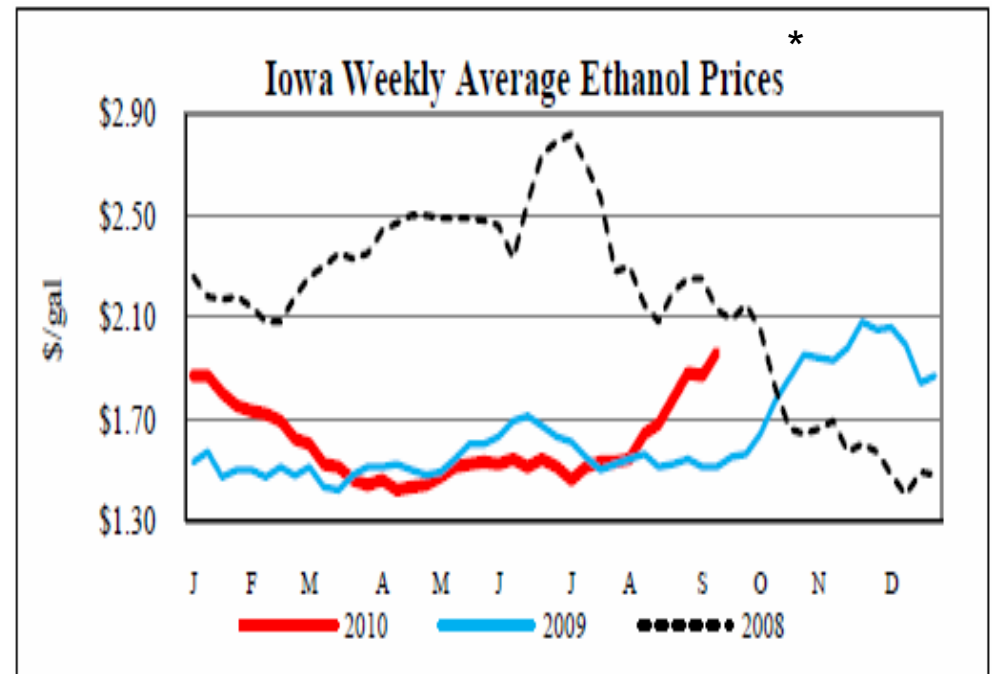

<http://www.ams.usda.gov/mnreports/lswethanol.pdf>

New Study (2010 “In Press”^{*}): Estimates cost of production for near-term biomass-to-liquid fuels (advanced) technology

Assumptions

- Corn Stover
- 2200 BDT per day feedstock (~725,000 BDT/year)
- \$75/BDT feedstock gate price
- ~37 MM gallons gasoline equivalent (gge) per year

Near-term Assumptions by technology	Capital (\$MM)	Yield (gal/BDT)	Yield (gge/BDT)
Cellulosic Ethanol	390	68	45
Gasification then Fischer-Tropsch (BTL)	560	49	53
Fast Pyrolysis then hydroprocessing	280	49	53

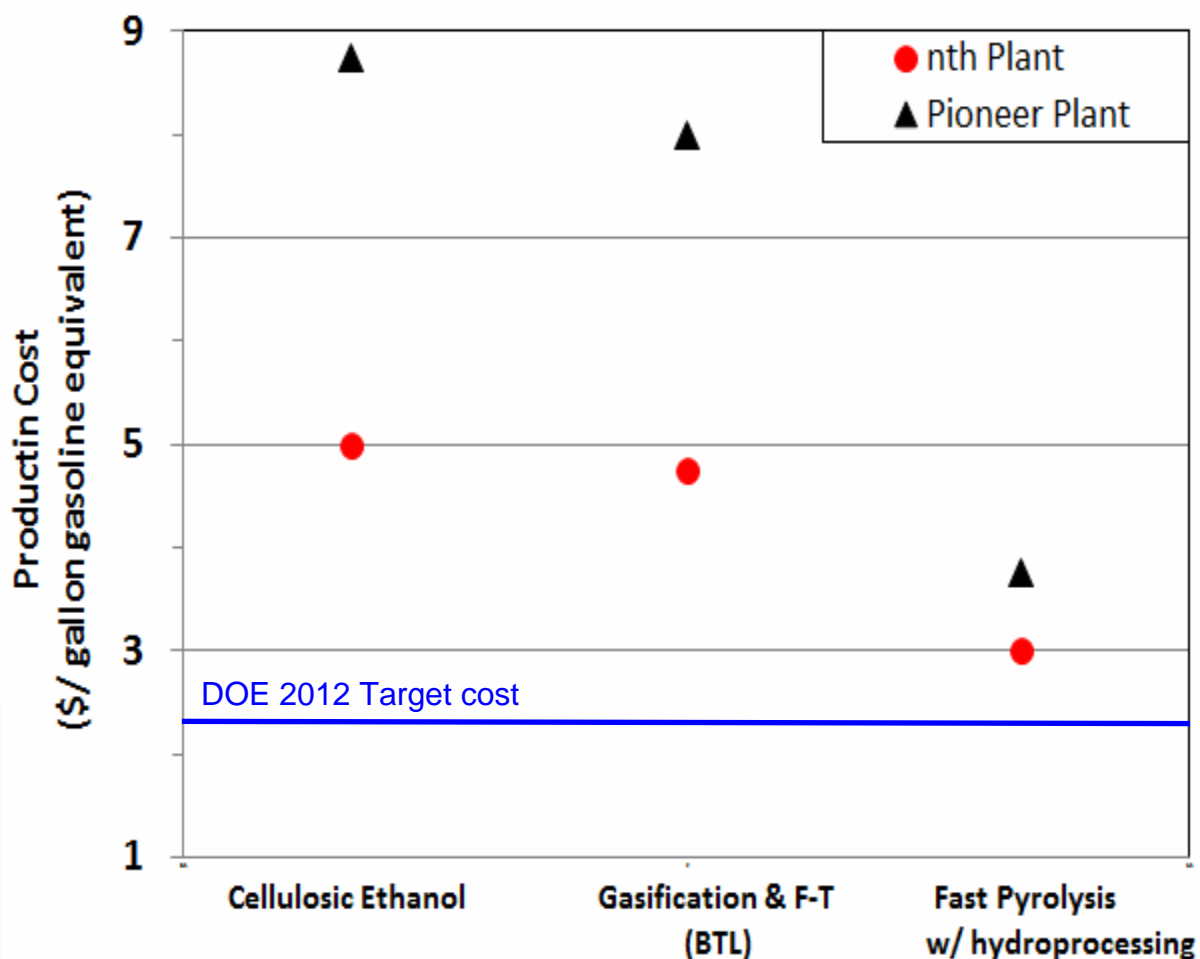

^{*} Source; Anex, RP et al., 2010 (Iowa State, NREL & ConocoPhillips)

(Some) US Cellulosic Biofuel Projects under development

Company	Proposed Location	Method	Proposed Feedstocks	Proposed Capacity (MM gpy)
Abengoa Bioenergy	Kansas	Combined Thermo- and Biochemical	Stover, straws, switchgrass, other	11.4
Abengoa Bioenergy	Nebraska	Biochemical	Stover, straws, switchgrass, other	11.5
AE Biofuels	Montana	Enzymatic Hydrolysis - Fermentation	Switchgrass, seed, straw, stover	small scale
BlueFire	Mississippi	Concentrated Acid- then Fermentation	Sorted green and wood waste	19
BlueFire	California	Concentrated Acid- then Fermentation	Sorted green and wood waste	3.1
Coskata	PA	Fermentation	Biomass, MSW, Ag residue	(40 thousand gpy)
Dupont	TN	Enzymatic Hydrolysis - then fermentation	Switchgrass, stover, corn cobs	(250 thousand gpy)
Ecofin, LLC	Kentucky	Altech solid state fermentation	Corn cobs	1.3
Fulcrum Bioenergy	Nevada	Gasification / catalytic upgrade	MSW	?
G4 Insights Inc.	Canada / California	Gasification to Synthetic Natural Gas (SNG)	Woody residues	Small demo
Harvest Power/ Agnion	California / Europe	Gasification to SNG	Urban wood waste , maybe biosolids	Small demo
ICM	Missouri	Enzymatic Hydrolysis - Fermentation	Switchgrass, forage, sorghum, stover	0.5
Lignol Innovations	Colorado	biochem - organosolve	Woody biomass, ag. residues, hard and soft woods	2.5
Mascoma	New York	Enzymatic	Switchgrass, paper sludge, wood	5
New Planet Energy	Florida	Gaddy - BRI (gasification, ferment syngas)	MSW, demolition debri, green waste	8-100
New Page	Wisconsin	Black Liquor gasification -to - liquid	woody biomass , mill residues	5.5
Pacific Ethanol	Oregon	Enzymatic - then fermentation	wheat straw, stover, poplar residues	2.7
POET	Iowa	Enzymatic - then fermentation	corn fiber, cobs, and stover	31
Range Fuels (Announces some methanol produced – in startup- Aug, '10)	Georgia	Gasification / catalytic upgrade	Purpose grown trees and forest wood wastes	20
Rentech	California, Mississippi	Gasification / catalytic upgrade	MSW, demolition debri, green waste	10
West Biofuels	California	Gasification / catalytic upgrade	Woody biomass, agr. and urban residues	(100 thousand gpy)
Zechem	Oregon		Poplar, sugar and wood chips	1.54

California Air Resources Board – LCFS various reports- see: <http://www.arb.ca.gov/fuels/lcfs/lcfs.htm>

Thank You

Rob Williams

Development Engineer
Biological and Agricultural Engineering
California Biomass Collaborative
University of California, Davis

Email: rbwilliams@ucdavis.edu

Phone: 530-752-6623

Web: biomass.ucdavis.edu

EISA* 2007 Biofuel Volume Mandates

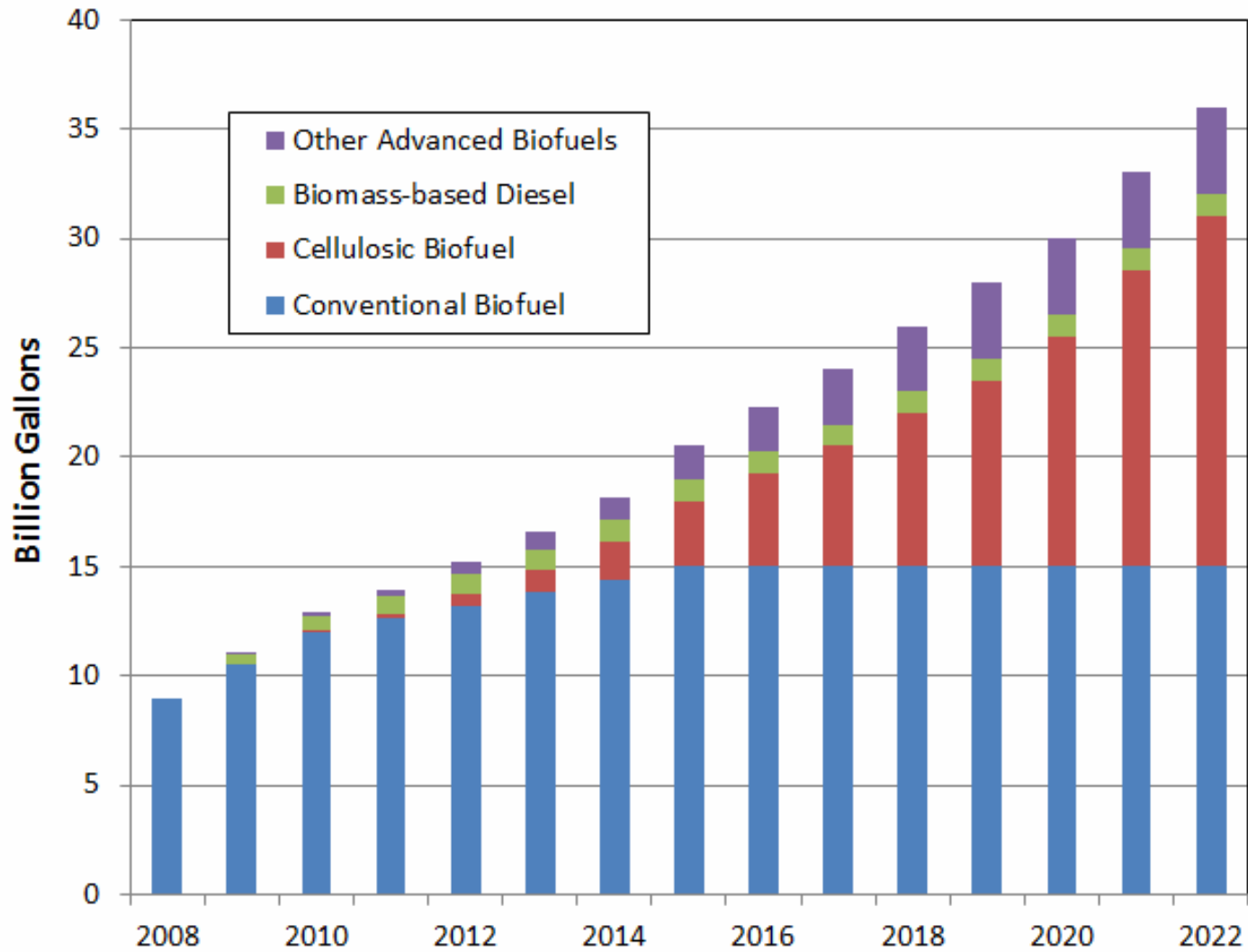

* Energy Independence and Security Act of 2007

http://www1.eere.energy.gov/biomass/federal_biomass.html

Miles per dry ton biomass (lignocellulosic)

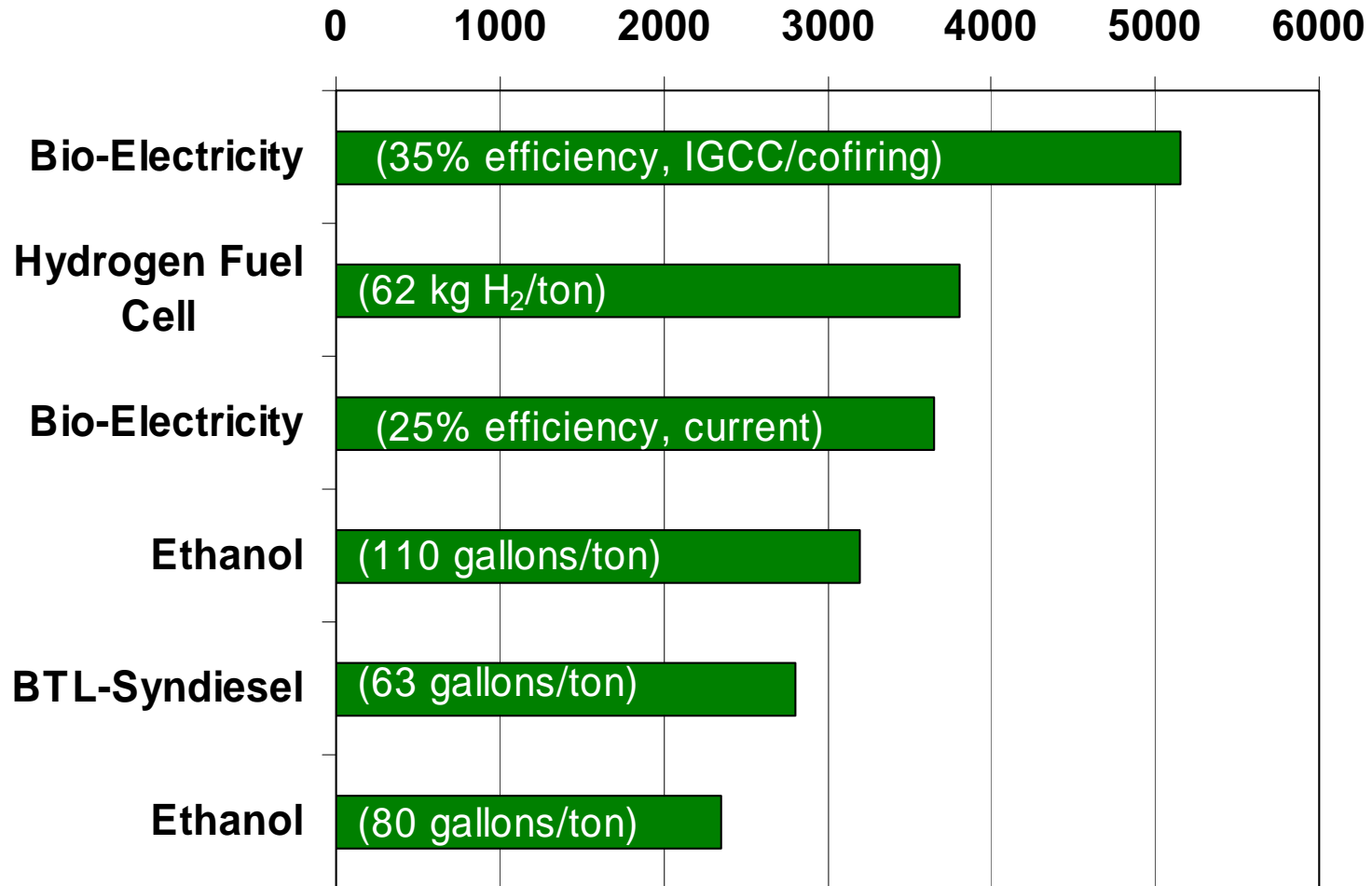

Based on hybrid vehicle with 44 miles per gallon fuel economy on gasoline, 260 Wh/mile battery (source: B. Epstein, E2). Electricity includes generating efficiency, transmission, distribution, and battery charging losses. Ethanol, BTL-Syndiesel, and H₂ include fuel distribution transport energy.

Source: B.M. Jenkins