

Potential Use of Transplants In Cool Season Vegetables and The Impacts on Weed Control

Richard Smith, Farm Advisor

University of California Cooperative Extension

Monterey County

Current Situation

- **Lettuce and broccoli in the Salinas Valley are basically direct seeded**
 - Transplanting is used early in the lettuce season and in order to keep plantings on schedule
- **However, other crops on the central coast are now transplanted:**
 - Celery
 - Cauliflower
 - Leeks
 - Peppers
 - Fresh market tomatoes

Why Transplant Celery

- Painfully slow initial seed germination and plant growth
- Transplanting reduces early season weed issues
- Celery transplants are mowed in the nursery and are uniform in size and easy for the transplant machine to handle
- An automatic transplanter was developed years ago that works well
- Conventional mechanical transplanters also work well given current cost of labor



Why Transplant Celery

- **Even with high plant populations the positives favor transplanting**
- **Celery has excellent registered herbicides (i.e. Caparol, Lorox, Dual Magnum, etc) and other weed control options that make weed control in transplanted celery economical and efficient**

Why Transplant Cauliflower

- **Low plant population (13,070) makes transplanting more economically viable**
- **Reduced weed issues**
- **Transplants produce acceptable quality**

Why Transplant Cauliflower



- Cauliflower also has a good set of herbicides (Dacthal, Prefar and Goal)
- The planting configuration allows for effective cultivation:
 - 1) close early cultivation
 - 2) can throw dirt on second cultivationSome growers just rely on cultivation

Why is Broccoli not Transplanted?

- High plant population (52,300) makes the economics of transplanting vs direct seeding more difficult
- Market demand is currently easily being met (no need for three crops!)

Broccoli Transplant Costs

Plants Per 1,000	Transplant Per 1,000	Total Cost Per 1,000	Total Cost Per Acre
6.50	8.00	14.50	758

Why is Lettuce not Transplanted?

- Moderately high plant population (26,150-31,300) makes the economics of transplanting vs direct seeding difficult
- Market demand is currently being met (no need for three crops?) with current rotation patterns
- Questions about the quality of transplanted head lettuce
- Other quality issues

Lettuce Transplant Costs

Not including seed



System	Plants Per 1,000	Transplant Per 1,000	Total Cost Per 1,000	Total Cost Per Acre
Conventional	10.50	8.00	18.50	485
Organic	13.50	8.00	21.50	563
Automated (Grower's Transplant)	----	----	16.50	432

Operation	Seeded	Transplants
Seeding	169	---
Transplanting	---	509
Fertilizer - Preplant	70	70
Fertilizer - Sidedress	102	102
Herbicide	48	48
Thin/weed	148	0
Hand Weed	57	57
Cultivation	27	10
Irrigation	167	167
Total Production Costs	788	963

Current Trends

- **Increase in cost of labor**
- **Decrease in the availability of labor**
- **Increased costs of inputs (water, fertilizer, pesticides, etc)**
- **Increased cost of land rent**
- **Need to intensify the use of land to cover increased costs**
- **New developments in technology**



Availability of labor



Automation



New Technology

Costly

High maintenance

What Will Agriculture in California Look Like in 10 Years

- **Will it be more or less as it is now?**
- **Will the trends we see in 2007 lead to a shift in the economics of production which force crops to be produced in a way that lends itself more to intensification and mechanization**

Based on this situation we feel it is important to explore new weed control options in the event that transplanting of broccoli and lettuce become more common place

Weed Control Options for Transplanted Broccoli

- **Goal is already registered specifically for pretransplant use in broccoli**
- **Broccoli also has excellent post emergence options (i.e. Goal Tender, topical fertilizer applications, grass herbicides)**

Weed Control Options for Transplanted Lettuce

- **Currently there are no herbicides registered specifically for transplanted lettuce in California**

Lettuce: Seedling vs Transplant

- **Lettuce is particularly sensitive to damage by herbicides in the seedling stage**
- **As a result there is a very short list of herbicides that are safe for preemergence use: Kerb, Prefar, Balan**



Lettuce: Seedling vs Transplant

Once lettuce is past the seedling stage:

- More tolerant of other herbicides
- More tolerant of physical manipulation



Weed Control Options for Transplanted Lettuce

- **Herbicide options for transplanted lettuce:**
 - **Prowl**
 - **Dual Magnum**
 - **Authority**

2006 Weed Evaluation

weeds/20 ft²

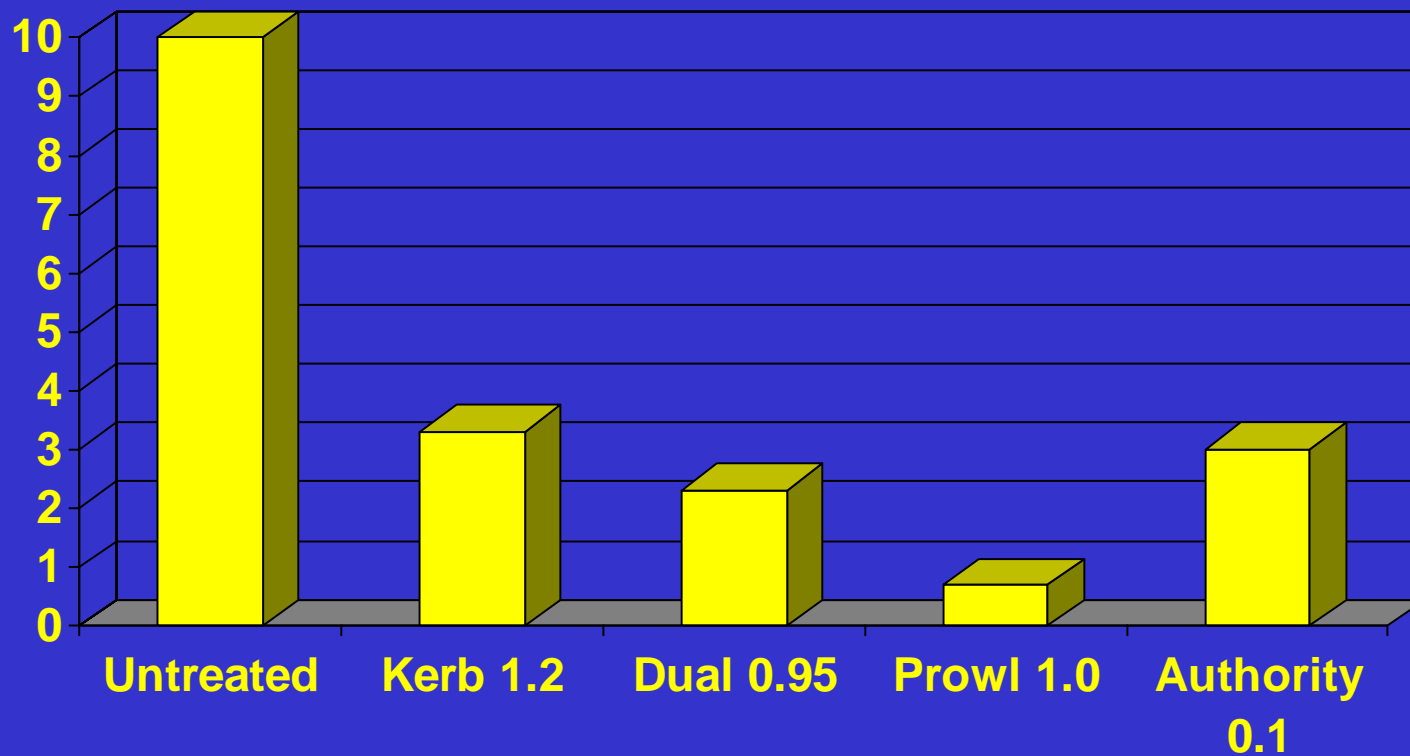

2006 Crop Safety Evaluation

Phytotoxicity

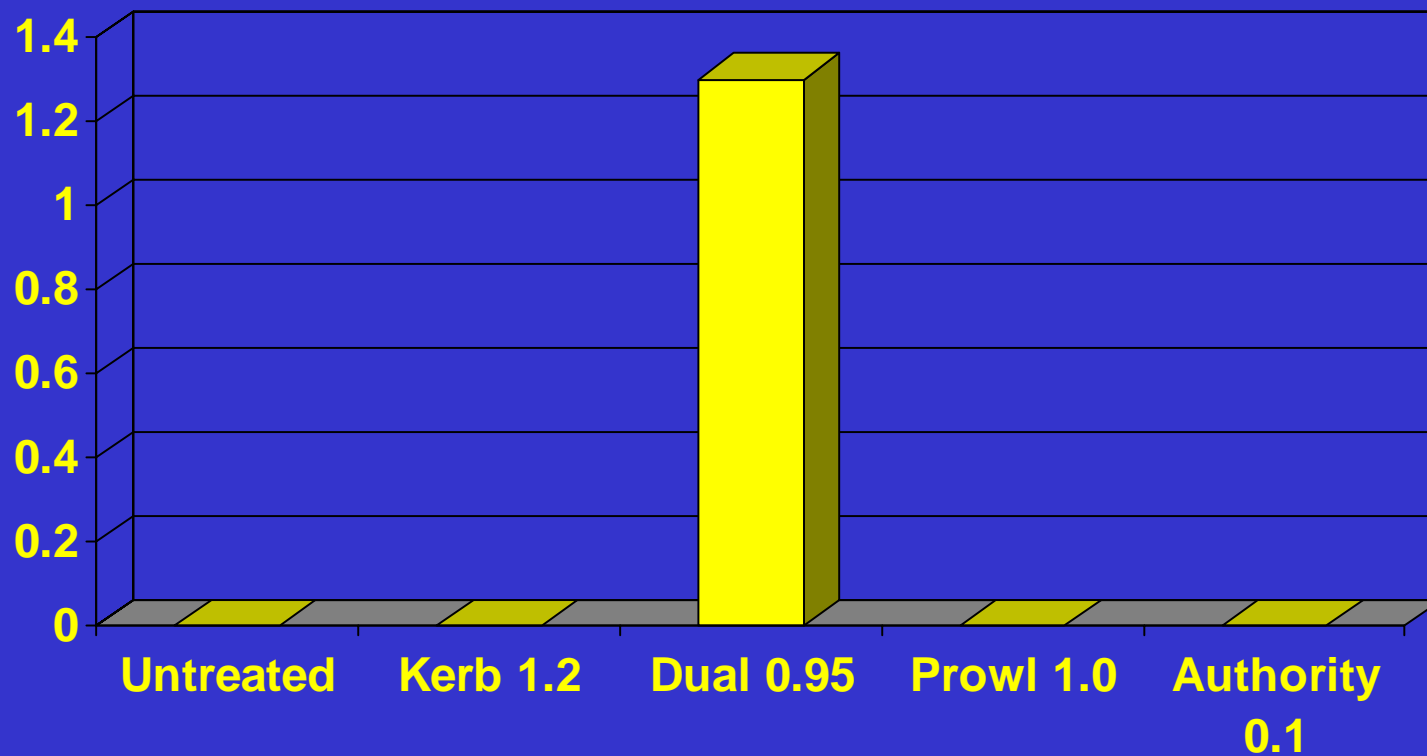

2006 Yield Evaluation

Heads per Plot

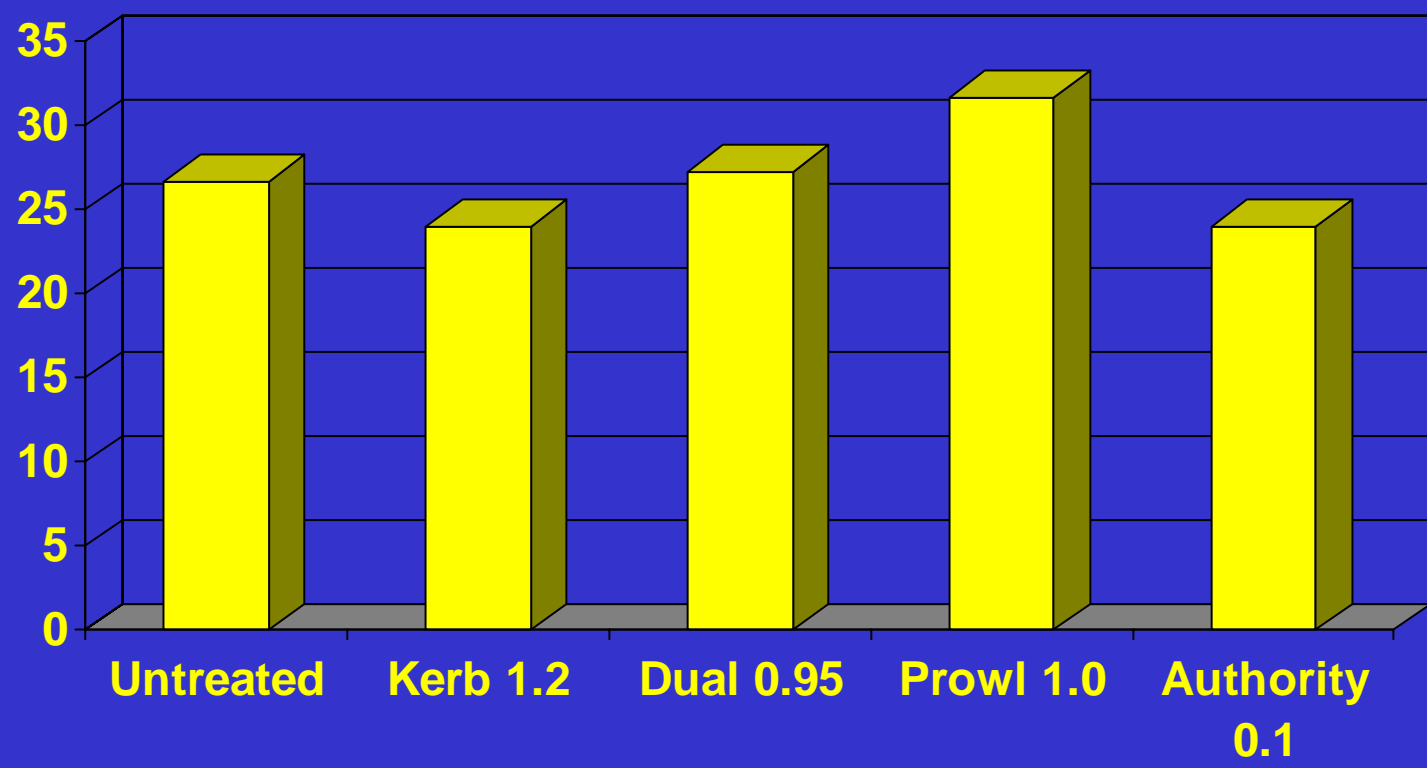

2007 Weed Evaluation

weeds/20 ft²

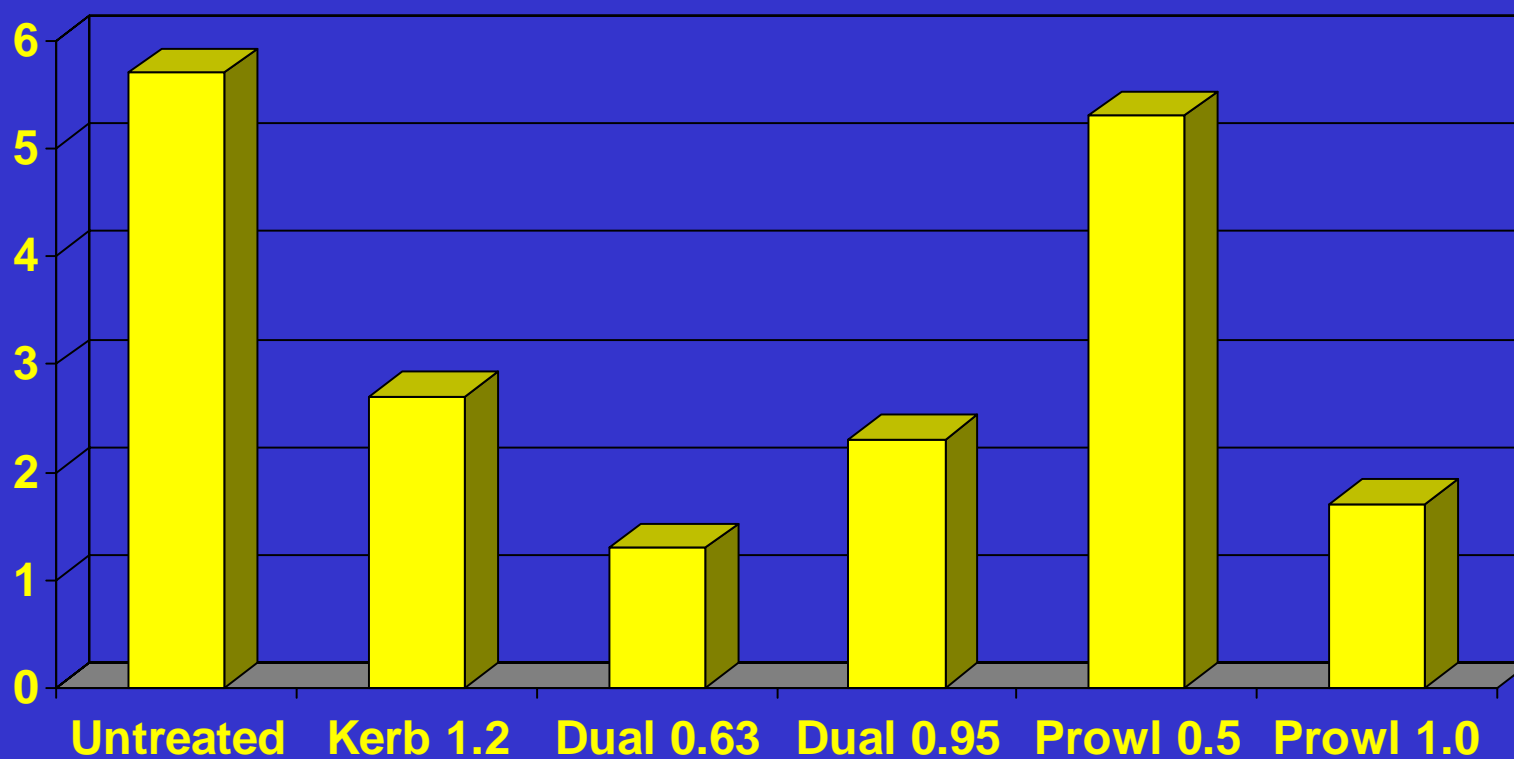

2007 Crop Safety Evaluation

Phytotoxicity Rating

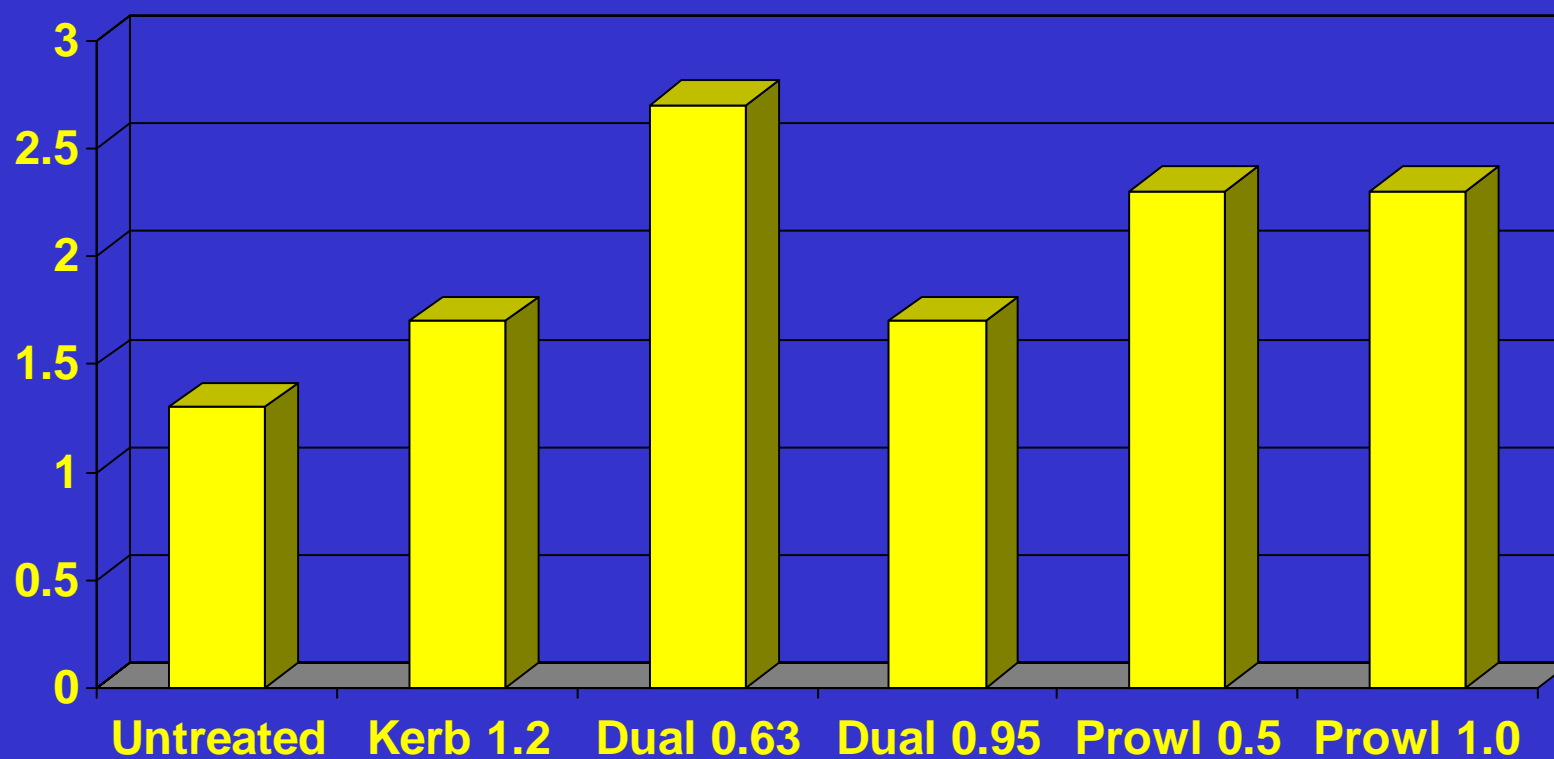

2007 Yield Evaluation

Mean Head Weight

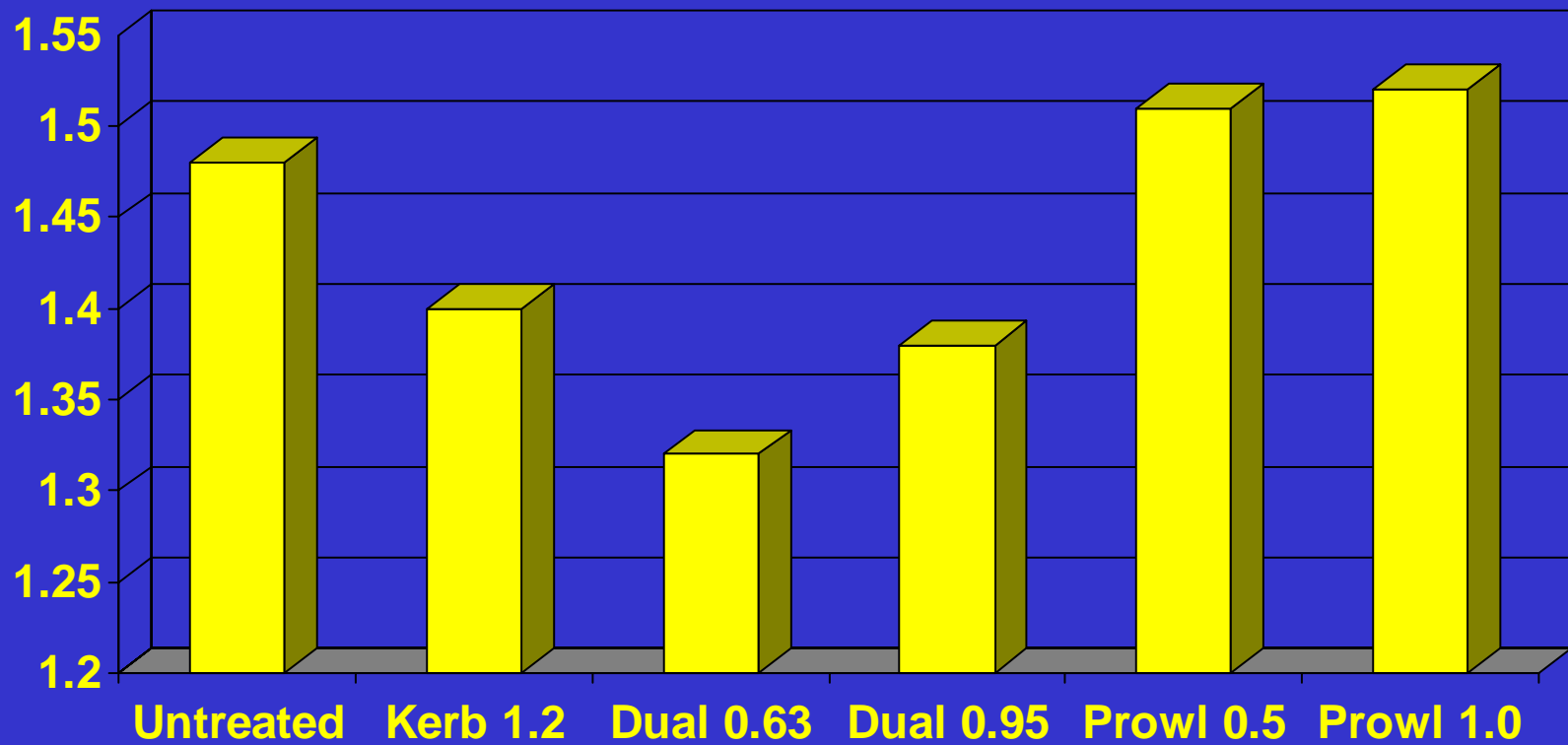

Herbicides for Transplanted Lettuce

- **Steve Fennimore has tested Prowl H2O at rates up to 6 lbs ai/A and has seen good safety**
- **He also tested tank mixes with Prowl H2O and Kerb and they look effective**
- **Prowl was submitted to the IR4 program to develop a food use tolerance for transplanted lettuce**

Cultivation

- **Transplants lend themselves to old and new technologies for weed control**
- **Transplants give the crop a head start on the weeds**
- **Transplants are more resistant to physical manipulation**
- **Transplants are bigger and therefore easier to detect and distinguish from the weeds by existing technology**

Close cultivation is not a new idea, but for larger operations, speed is a concern



Precision Guidance of Cultivators

2" wide band vs standard 4" band



Intra-row cultivation



Split Knife

Dave Slaughter, UCD

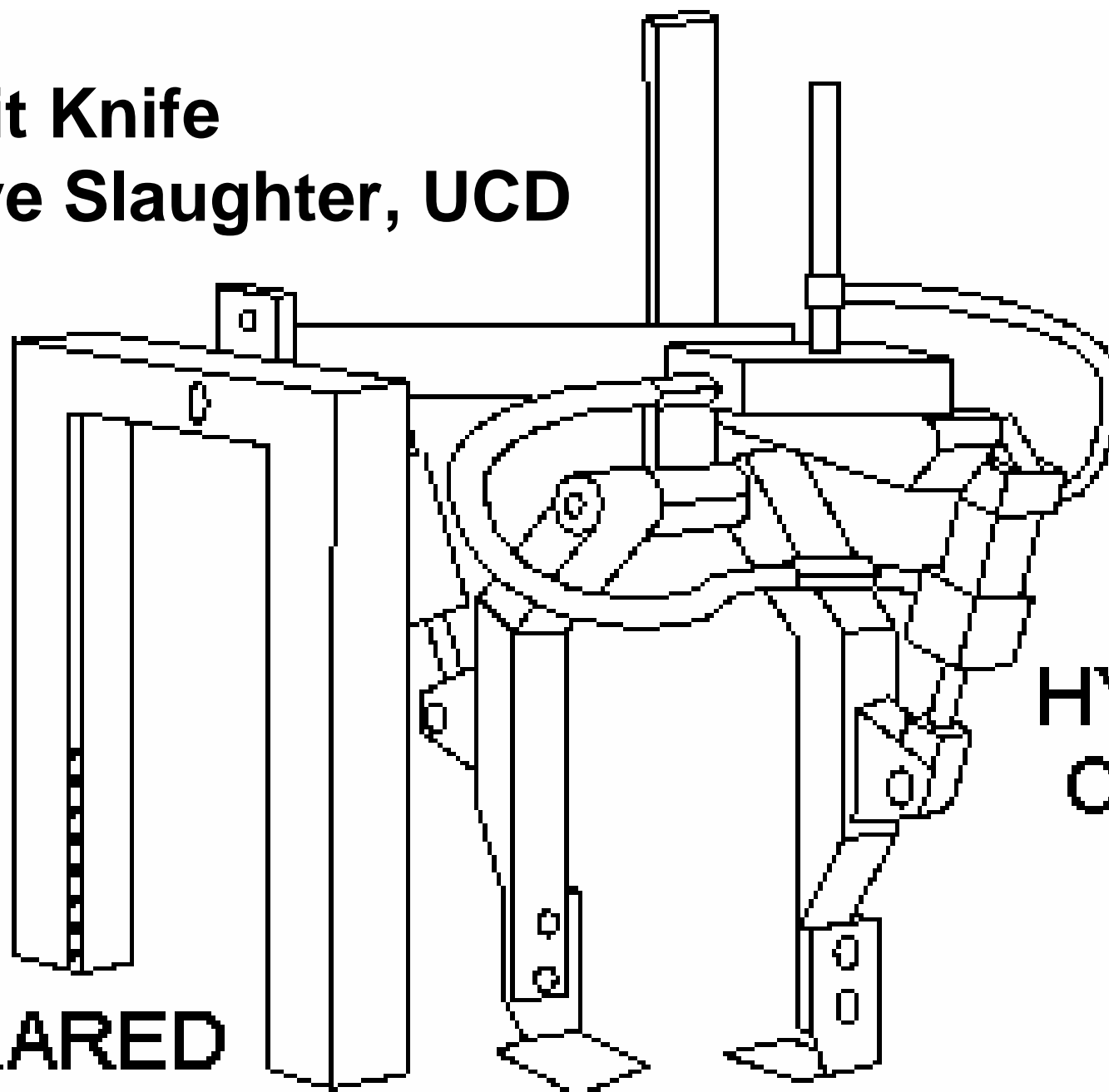

HYDRAULIC
CYLINDER

INFRARED
SENSOR

KNIFE

Automated Weed Control in Transplanted Tomatoes

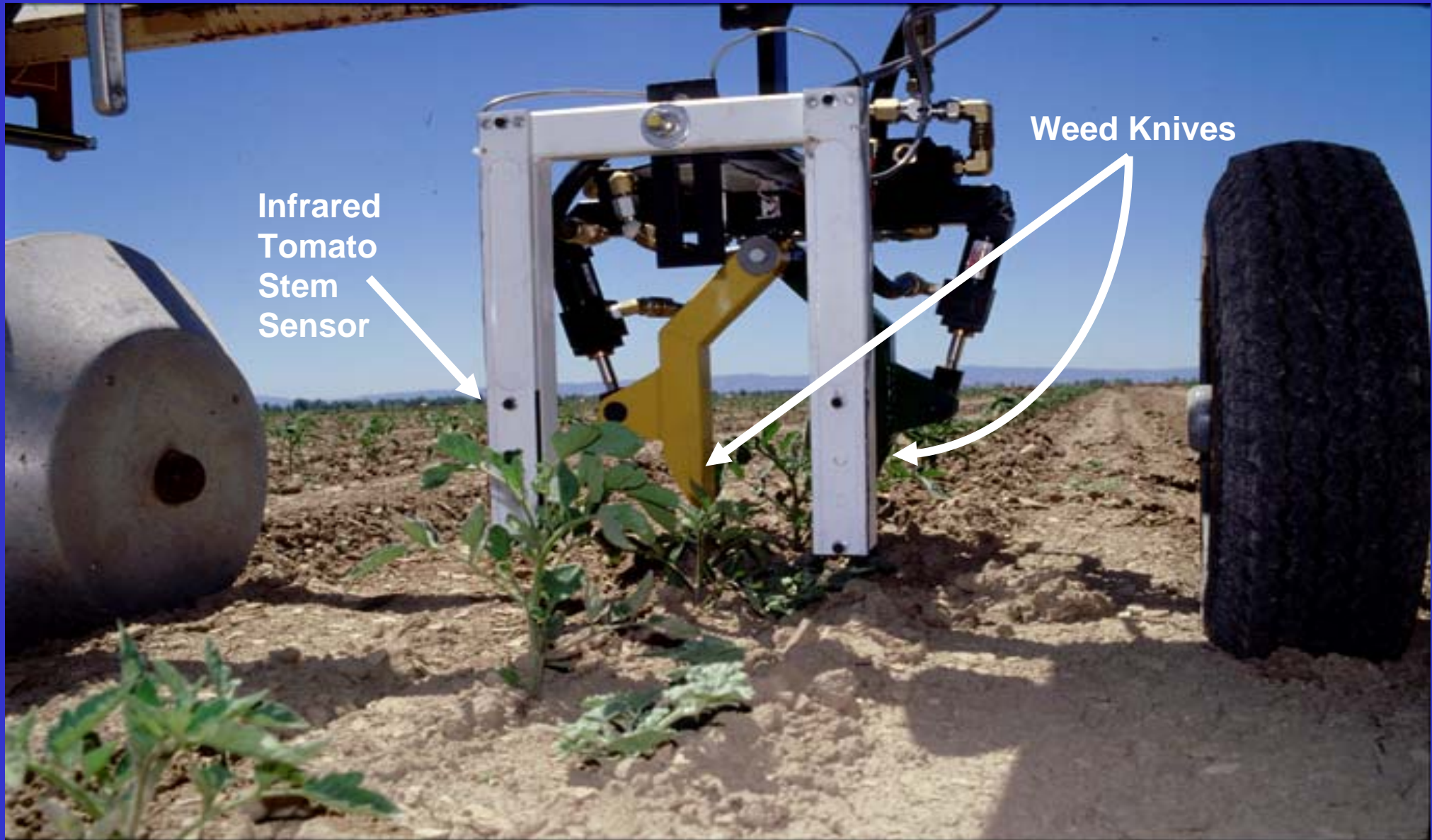

Torsion Weeder
Used extensively in Europe
Similar to the Texas Rod Weeder
once popularly used in cotton



**Come in different
Sizes (7 & 9 mm)**

**Can be adjusted
To different
Widths apart**





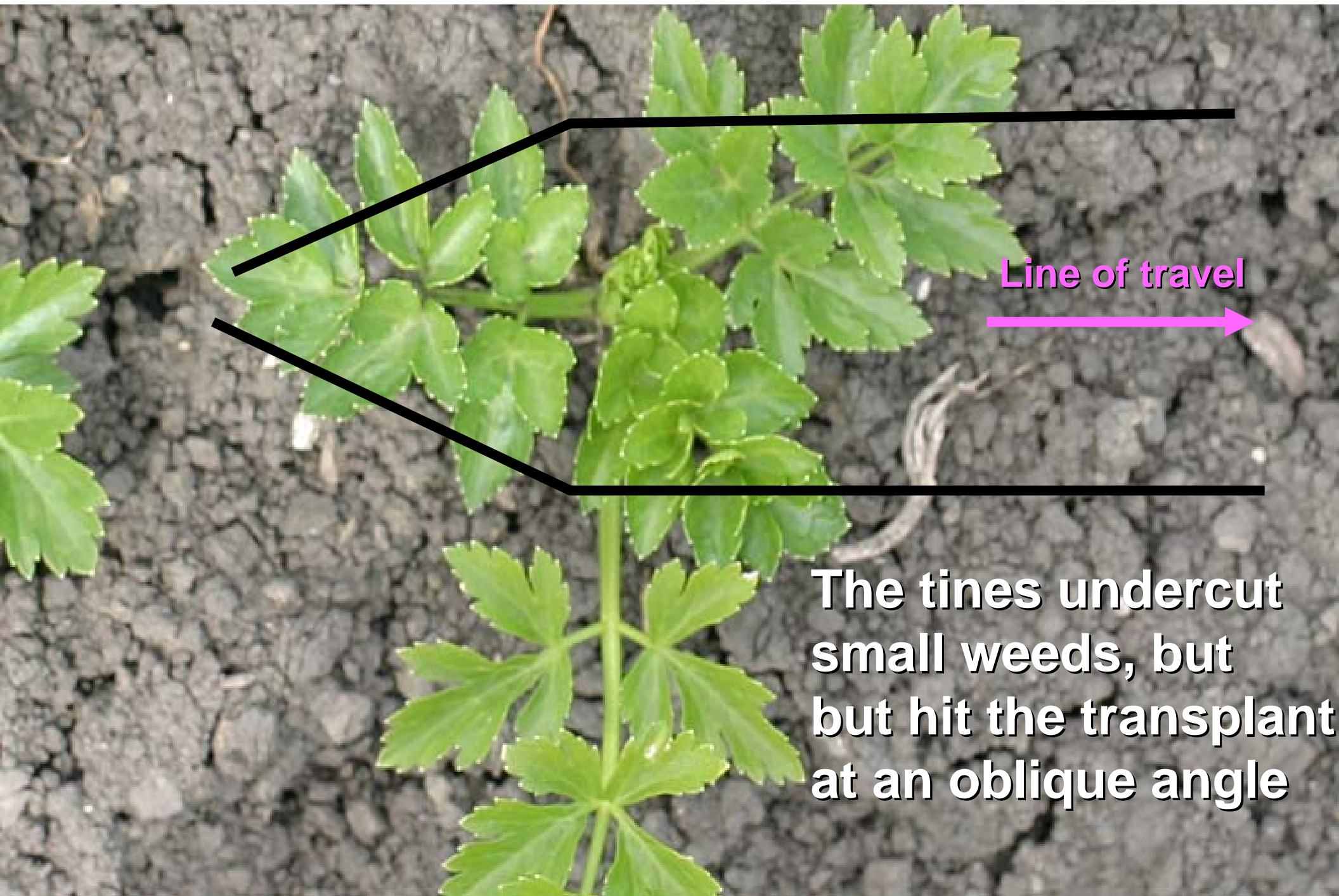

Line of travel



The tines undercut small weeds, but but hit the transplant at an oblique angle



Percent Weed Control

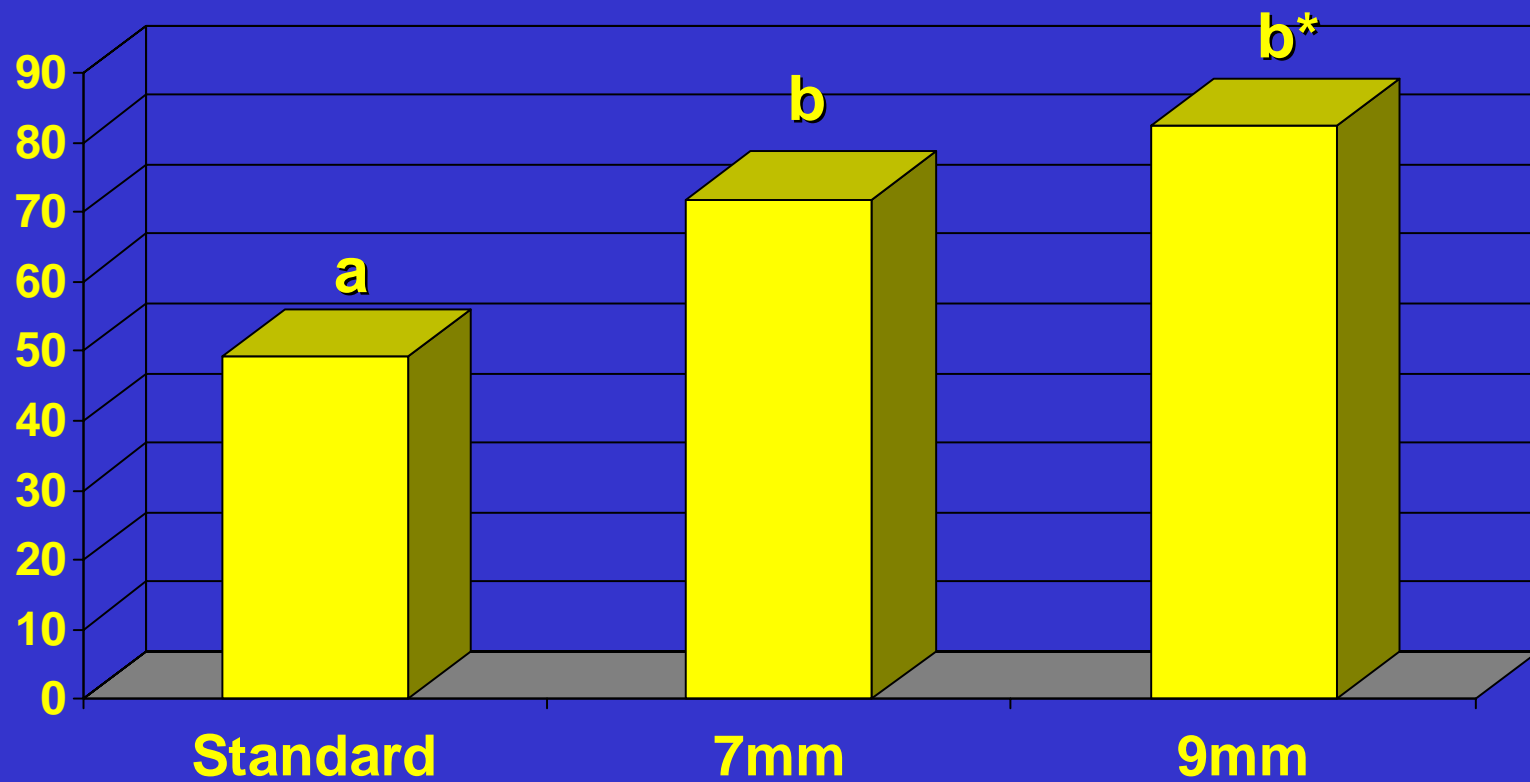

* Different than 7mm @ P=0.10

Plants Per Acre

x1,000

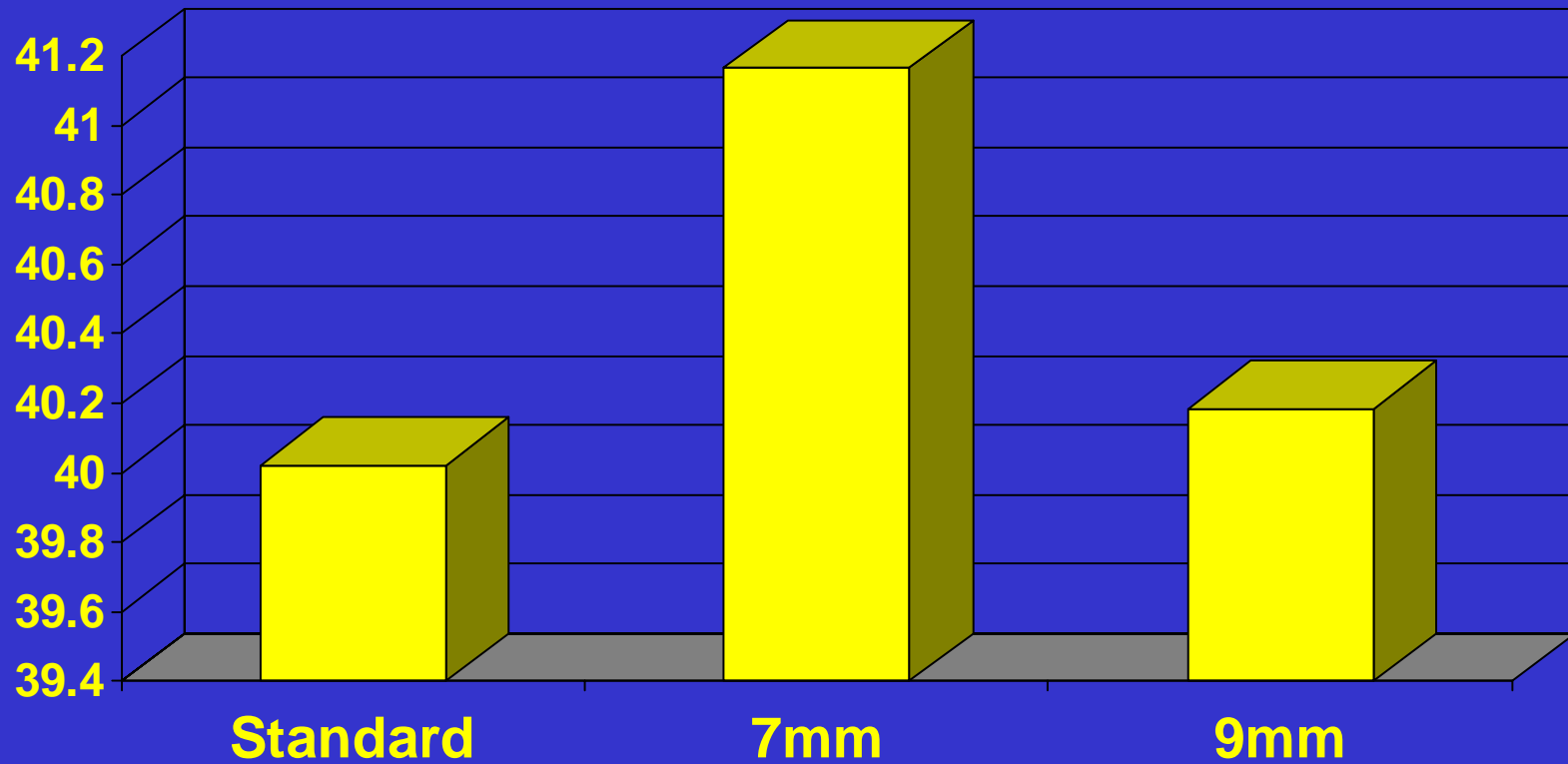

Mean Head Weight lbs

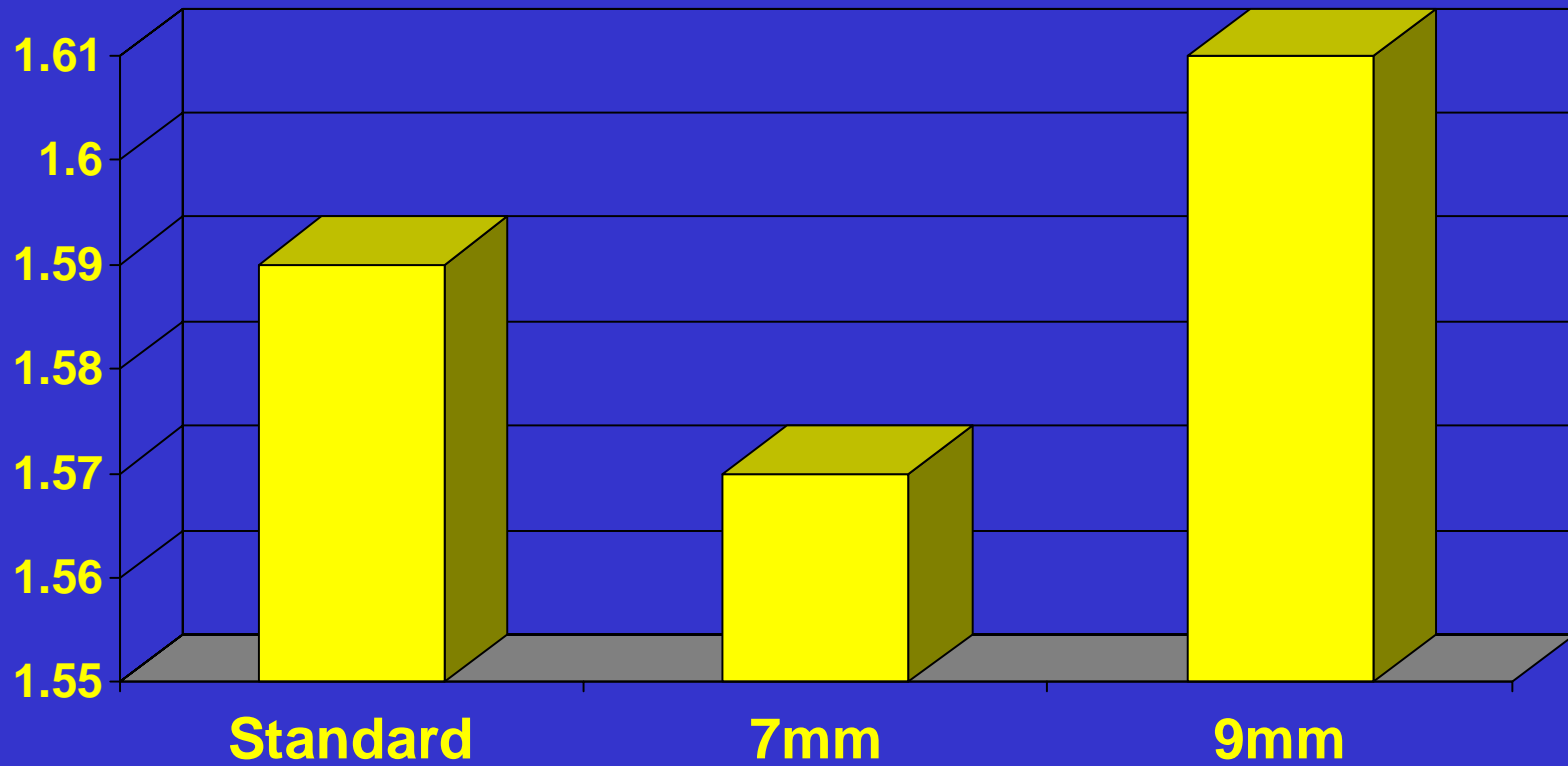

Prototype Intra-row weeder



Garford Farm Machinery

- * This machine is being commercialized
- * It will be dependant upon good ability to distinguish between crop and weeds which transplanting will facilitate

Final Thoughts

- It is unclear if transplanting of lettuce will take off in the Salinas Valley, but it seems likely
- It may open the door to the use of hybrids in order to improve uniformity
- If it does, it will change weed control practices and give growers opportunities to use new and more effective tools