

Precision Cultivation for Vegetable Production

Richard Smith, Farm Advisor

University of California Cooperative Extension

Monterey County

Coastal Vegetable Production

- **Spinach, baby lettuce**
 - High density 80-inch beds
- **Lettuce, broccoli**
 - 40 inch beds (two seedlines)
 - 80 inch beds (5-6 seedlines - lettuce)

Cultural Practices for Managing Weeds

- **Fastidious weed management practices in prior rotations can, over time, reduce weed pressure to manageable levels**
 - **Aggressively controlling weeds in all prior rotations and during the fallow period over the winter**
 - **Not letting weeds go to seed**
 - **Carrying weeds out of the field during weeding operations**

Cultural Practices to Reduce Weed Pressure

- **Field selection**
- **Avoidance:**
 - **Avoiding weedy fields**
 - **Avoiding weediest time of the growing season (i.e. purslane during June to Sept.)**
- **Pre-germination of weeds**
- **Use of “stale” seedbeds**
- **Planting vigorous varieties on weediest area**

Effects of Preirrigation

No Preirrigation



With Preirrigation



- Reduces the number of weed seed that are ready to germinate in the top layer of the soil
- Can reduce weed emergence in subsequent crop by up to 50% (Shem Tov and Fennimore)

Cultural Practices to Reduce Weed Pressure

- Control weeds that aerial disperse from surrounding areas
- Not letting weeds go to seed
- Carrying weeds from the field for disposal elsewhere
- Carefully planning crop rotations
- Organic herbicides
- Deep plowing
- Cultivation
- Hand weeding
- Bio-fumigation
- Cover crops!?

Issues Specific to High Density 80-Inch Beds

Weed Control on High Density 80-Inch Beds

Challenges

- **High density (24 – 32 seedlines) stands are difficult to impossible to effectively cultivate (on 40-inch beds we can cultivate 80 to 85% of the bed)**
- **Difficult and expensive to hand weed**
- **Key weeds that are difficult to control**
- **Low tolerance for weeds in mechanically harvested product**

Mechanical Harvest





Only area that can be cultivated

**28 seedlines on this bed
does not lend itself to
cultivation**



Difficult, Tedious and Expensive to Hand Weed





Cultivation

- **High density stands on 80-inch beds are difficult to impossible to effectively cultivate**
- **Some growers have planted fewer seedlines (i.e. 14) in order to be able to cultivate**



Brush Hoe Cultivator

Bartchi-Fobro (Switzerland)



Human vs Machine Guidance



Brush Hoe Cultivator



Cultivated

Uncultivated

Brush Hoe Cultivation of 14 line High Density Spring Mix Lettuce

Treatment	Weed Control Percent	Weed time hrs/A	Yield Lbs/A
Brush hoe	47.8	11.0	11,731
Uncultivated	0.0	17.0	13,765

Summary

- **Weed control on high-density beds is mostly achieved prior to planting**
- **In other words the long-term effect of prior farming practices affect the weed population**
- **Cultivation with 14 or fewer seedlines can be used, but other factors such as food safety may preclude its use**
- **Current cultivation guidance systems will not work to guide the cultivator**

Issues Specific to Vegetables Grown on 40 and 80 inch Beds

Issues Specific to Mature Lettuce Grown on 40 and 80 inch Beds

- **For organic production, the cultural practices already mentioned are critical**
- **Once the crop is planted, effective cultivation can be accomplished**
- **If effective cultural practices and cultivation are carried out, hand weeding can be made more efficient and economical**

Close cultivation is not a new idea, but speed is a concern for bigger operations





**Typically 80+%
of a 40-inch
wide bed can
be effectively
cultivated. The
fight with weeds
occurs in the
uncultivated
seedline**

Precision Guidance of Cultivators

2" wide band vs standard 4" band



**Tried and true
slow**



2 inch band



4 inch band

Percent of Weeds Controlled at Different Cultivation Band Widths

2005 Lettuce Trial No. 1

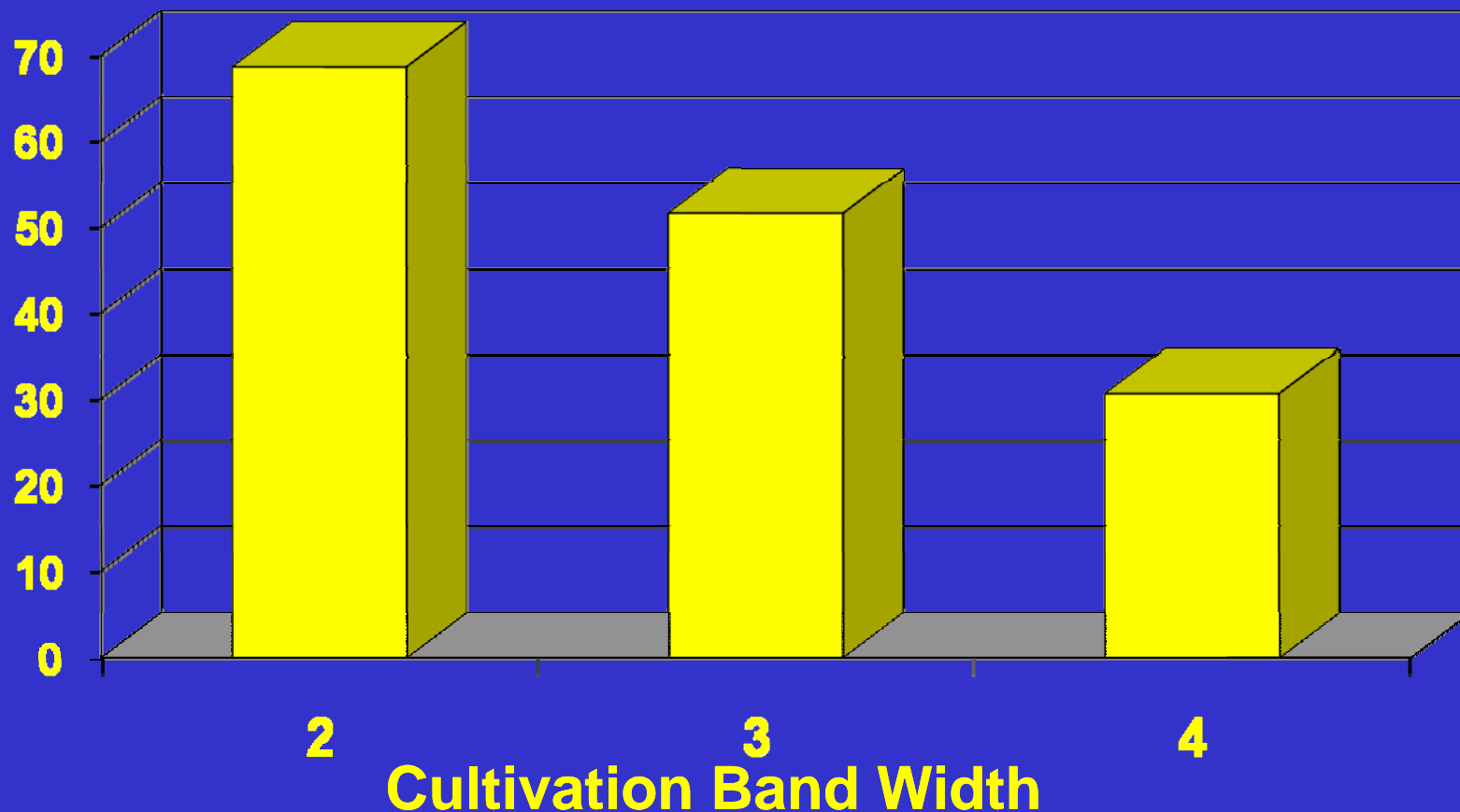

Hours Per Acre to Weed Different Cultivation Band Widths

2005 Lettuce Trial No. 1

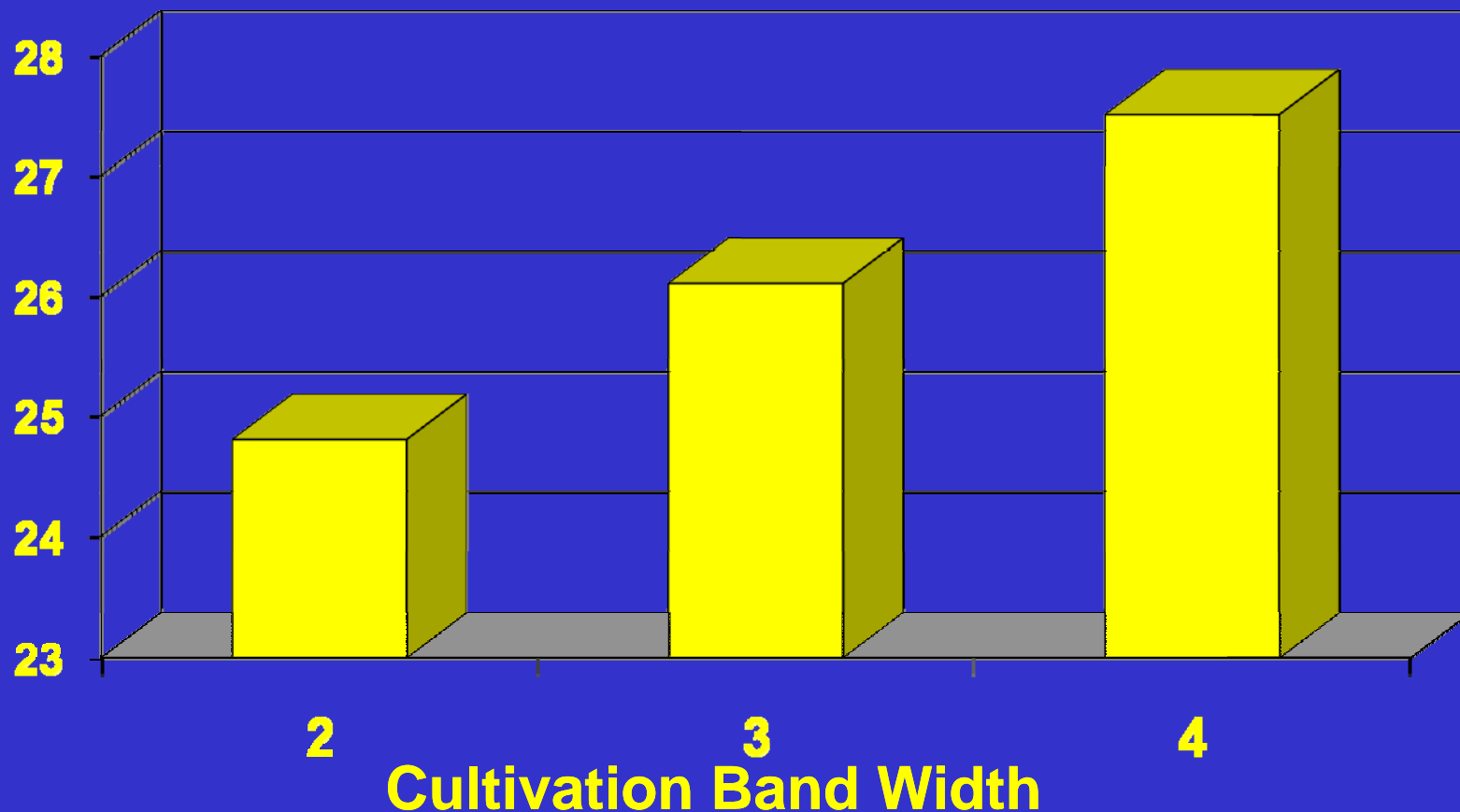



Percent Weed Control Different Cultivation Band Widths

2005 Broccoli Trial No. 1

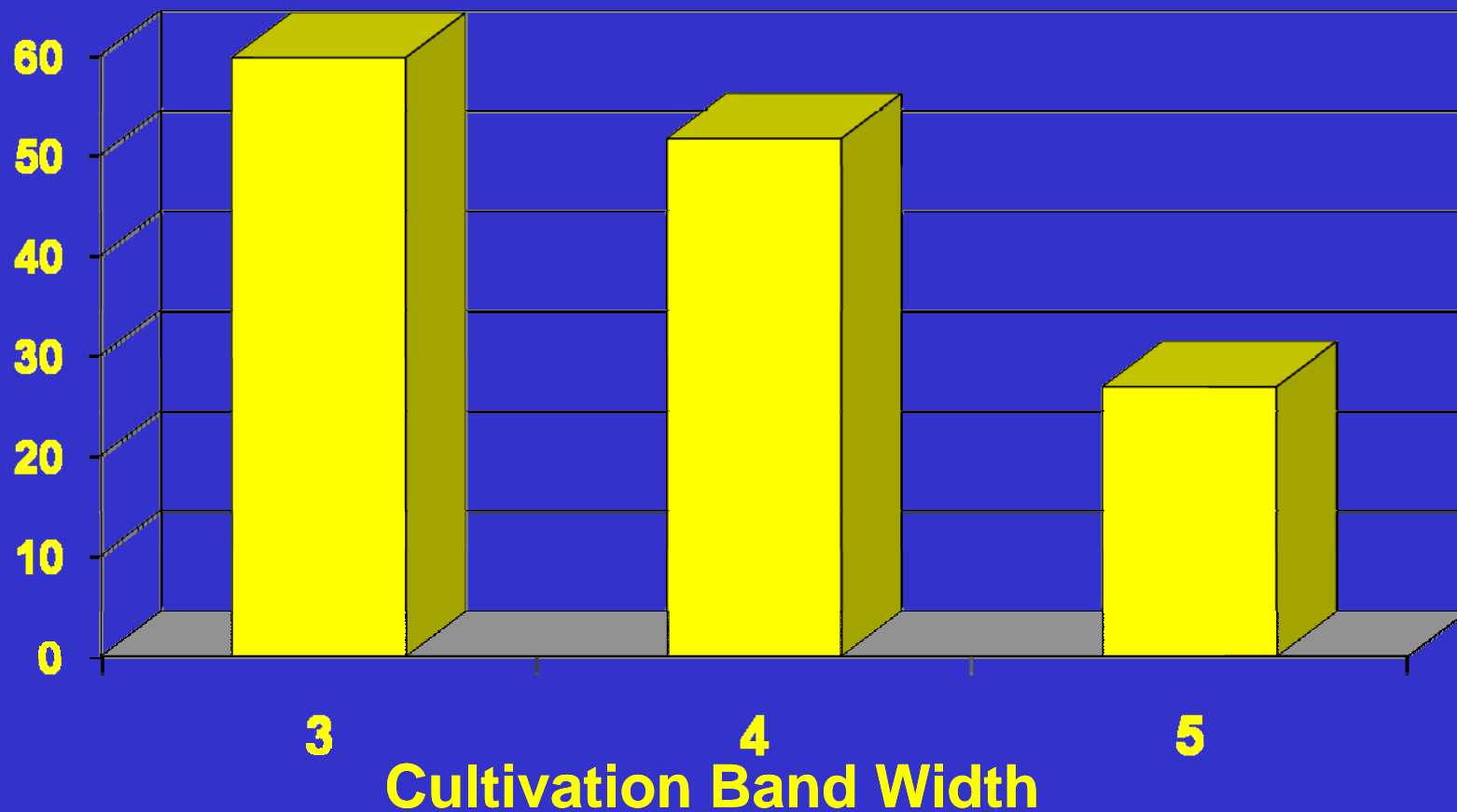

Weeding Time

Different Cultivation Band Widths

2005 Broccoli Trial No. 1

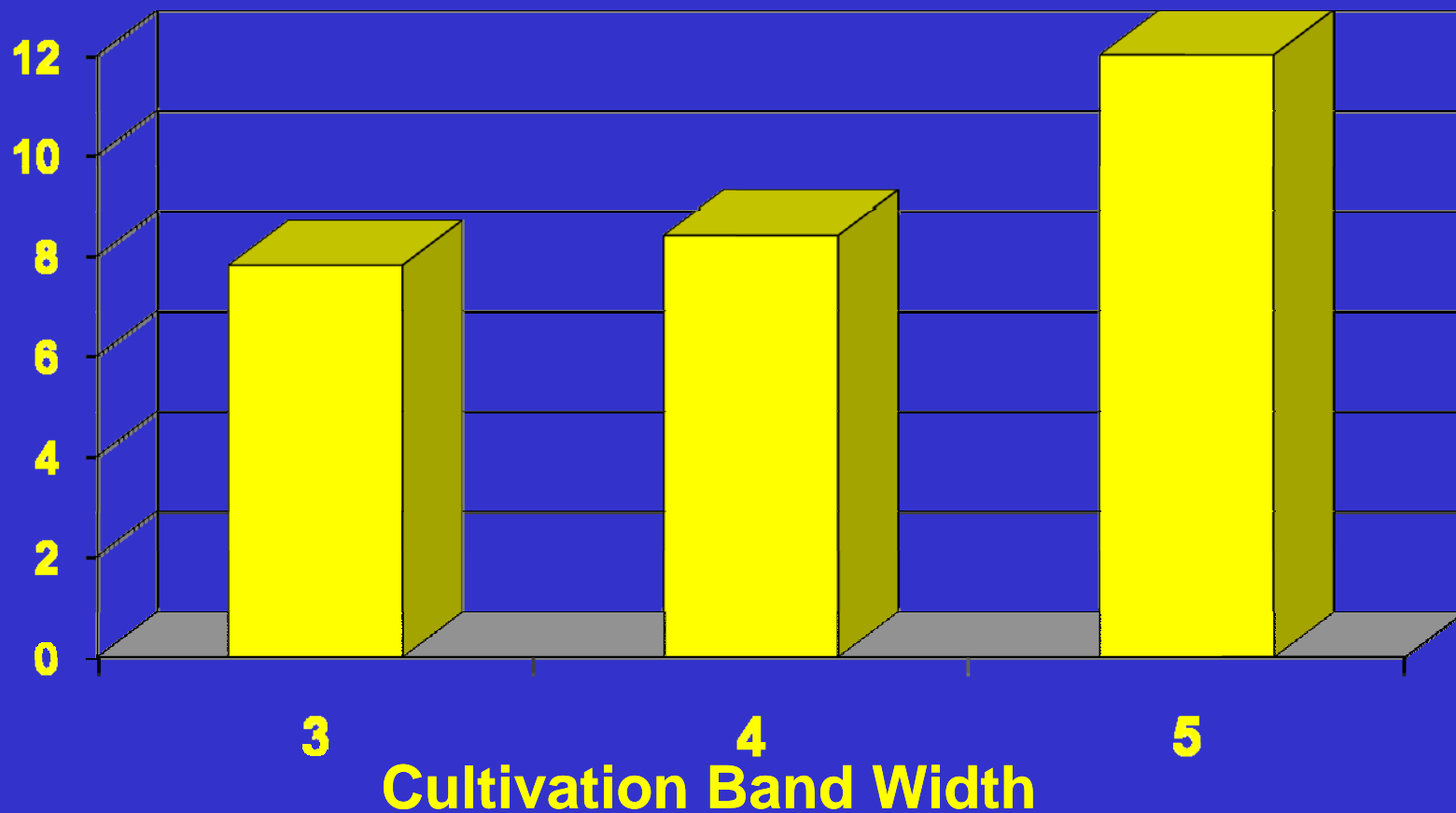

Summary of Precision Cultivation

- **The EcoDan and Robocrop guidance systems allow close cultivation without reducing speed**
- **Close cultivation is able to remove a greater percentage of weeds and reduce weeding time accordingly**

Use of Transplants

- **Transplants lend themselves to old and new technologies for weed control**
- **Transplants give the crop a head start on the weeds**
- **Transplants are more resistant to physical manipulation**
- **Transplants are easier for high tech mechanical weeders to recognize (distinguish from the weeds)**

Intra-Row Cultivation

- High Tech Ideas
- Lower Tech Ideas

Split Knife

Dave Slaughter, UCD

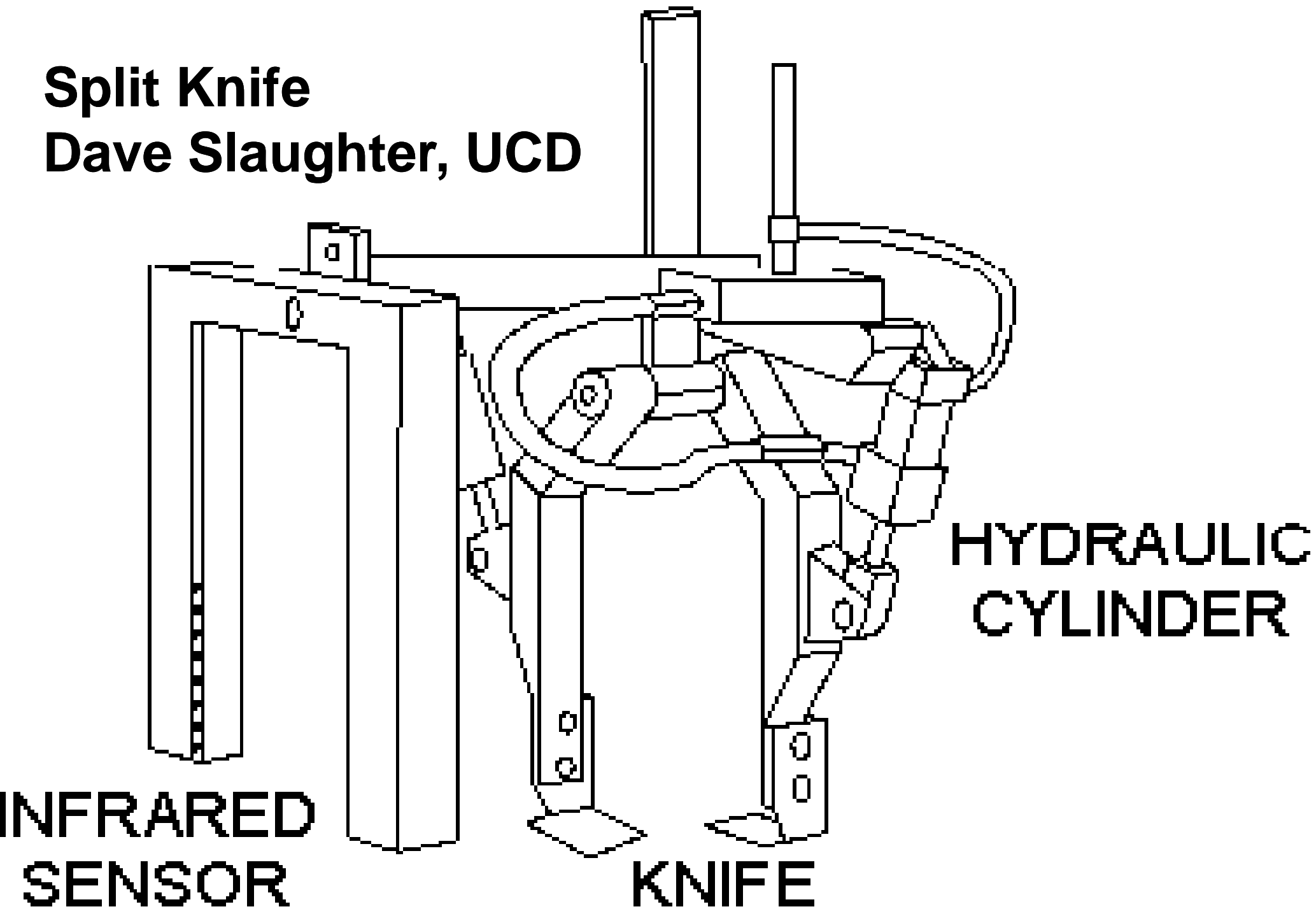

Automated Weed Control in Transplanted Tomatoes

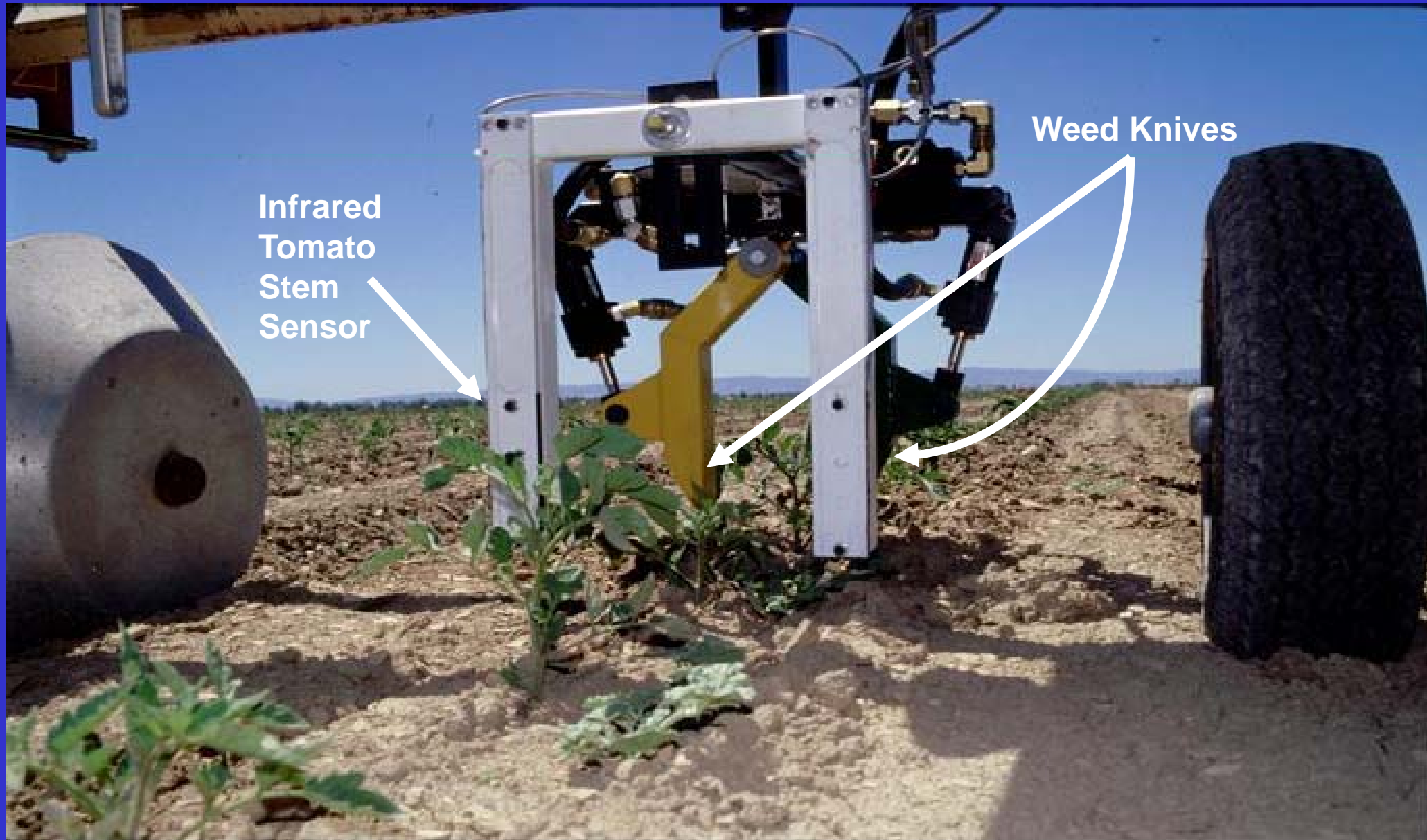

Automatic Cultivator/Thinner

Tillet and Hague (England)

Tillett and Hague
Technology Ltd



Intra-Row Cultivation

- High Tech Ideas
- Lower Tech Ideas

Blind Cultivation



Spring tined (Lely)
onions, beans , others



Rotary hoe – small grains

Finger Weeder

Kress (Germany)



Torsion Weeder

Frato (Netherlands)



Torsion Weeder

Inexpensive

Can be attached to existing cultivation equipment
and go as fast



**Come in different
Sizes (7 & 9 mm)
Width can be adjusted**



Celery



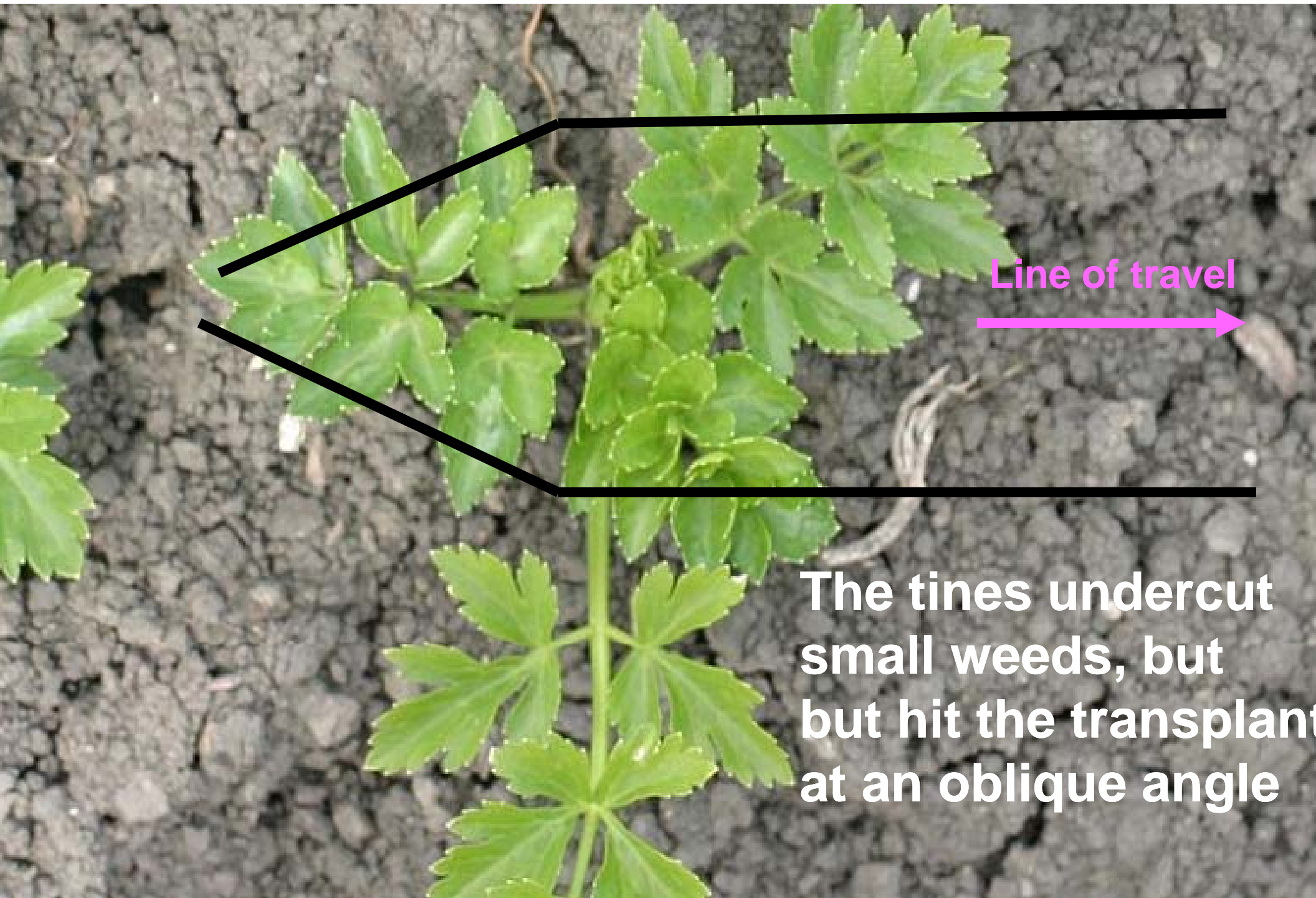

Line of travel

The tines undercut small weeds, but but hit the transplant at an oblique angle



Celery 2007 Trial Percent Weed Control

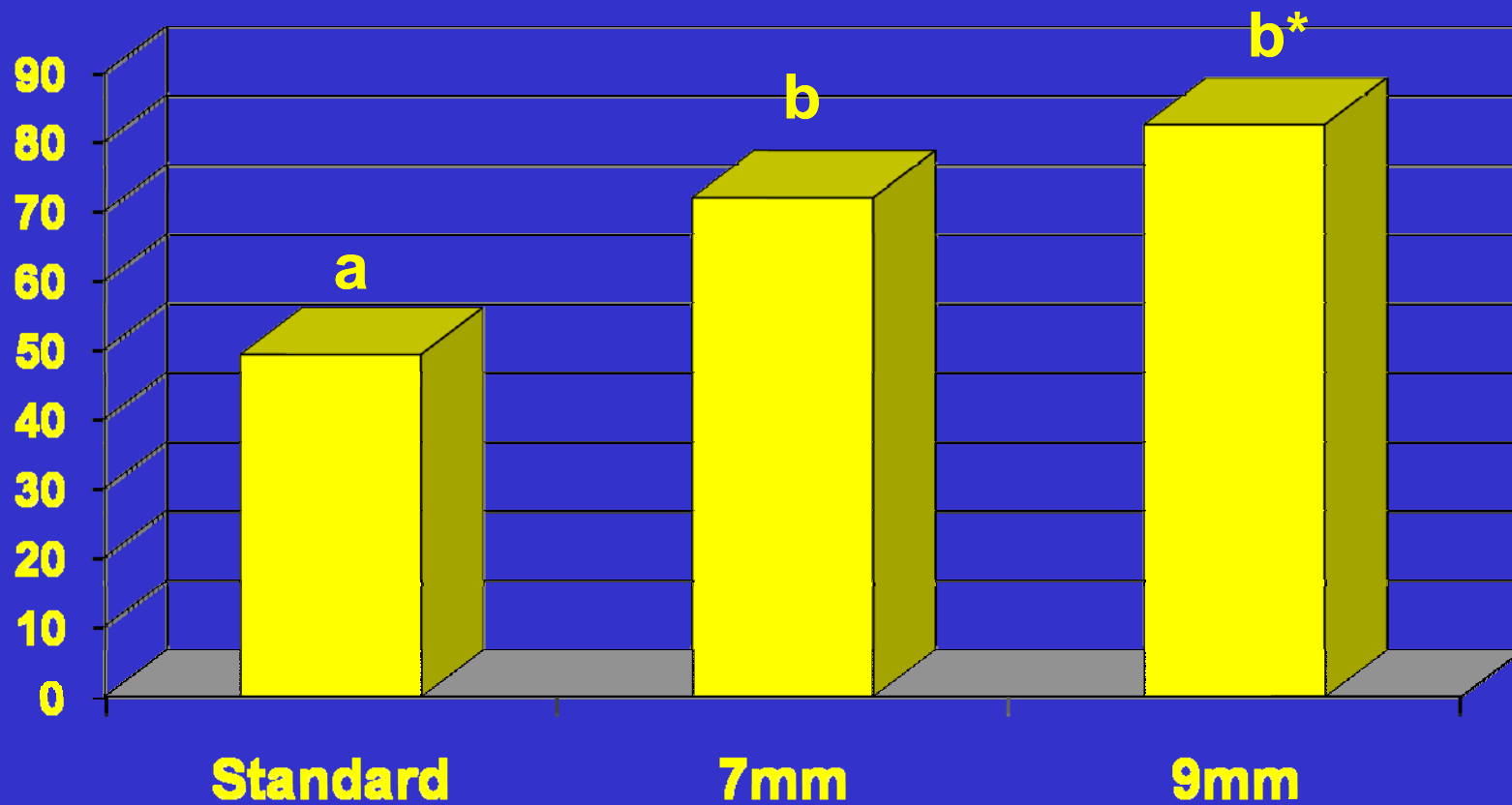

* Different than 7mm @ P=0.10

Celery 2007 Trial

Mean Head Weight lbs

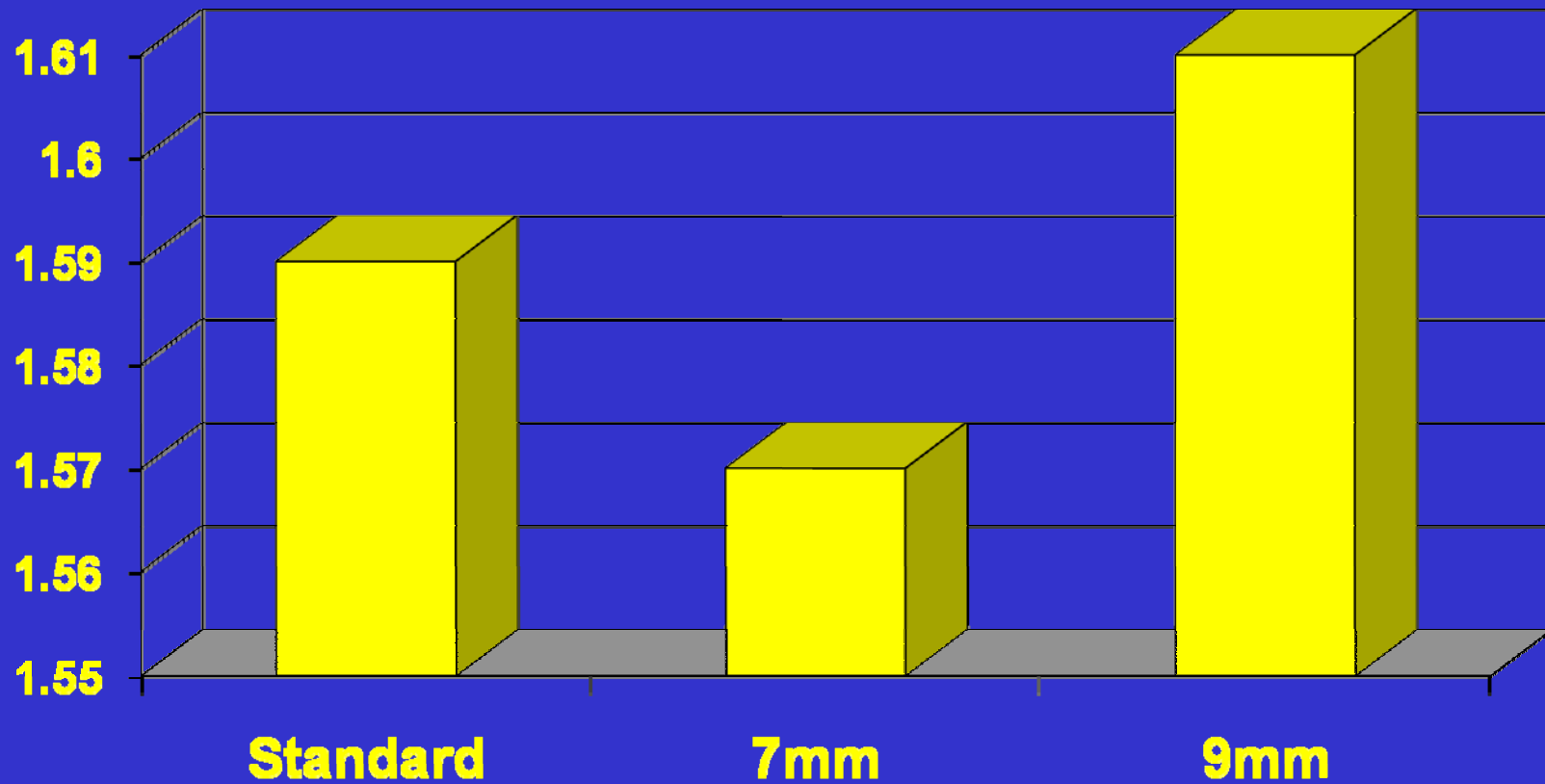

Leeks



Leeks Percent Weed Control

2007

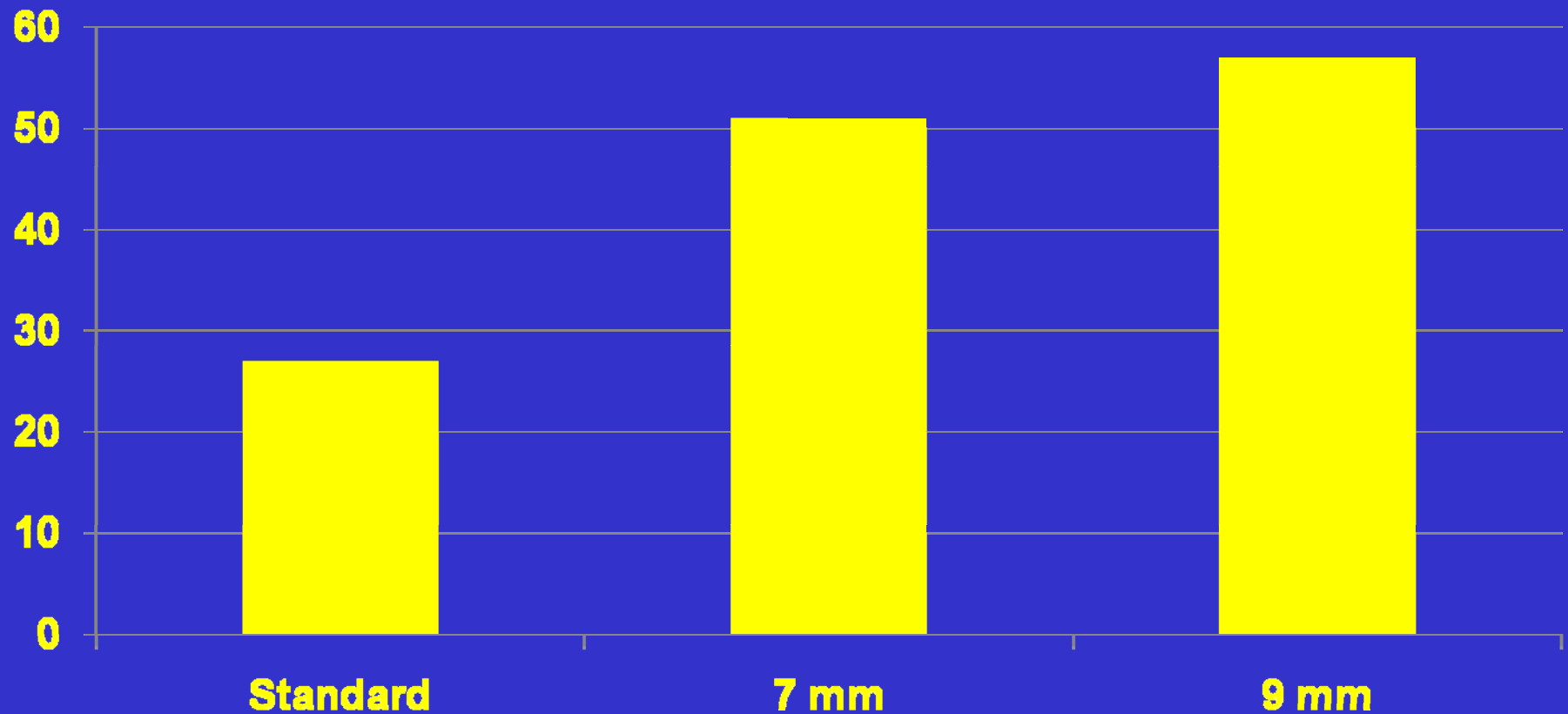

Leeks Hour/A to Weed

2007

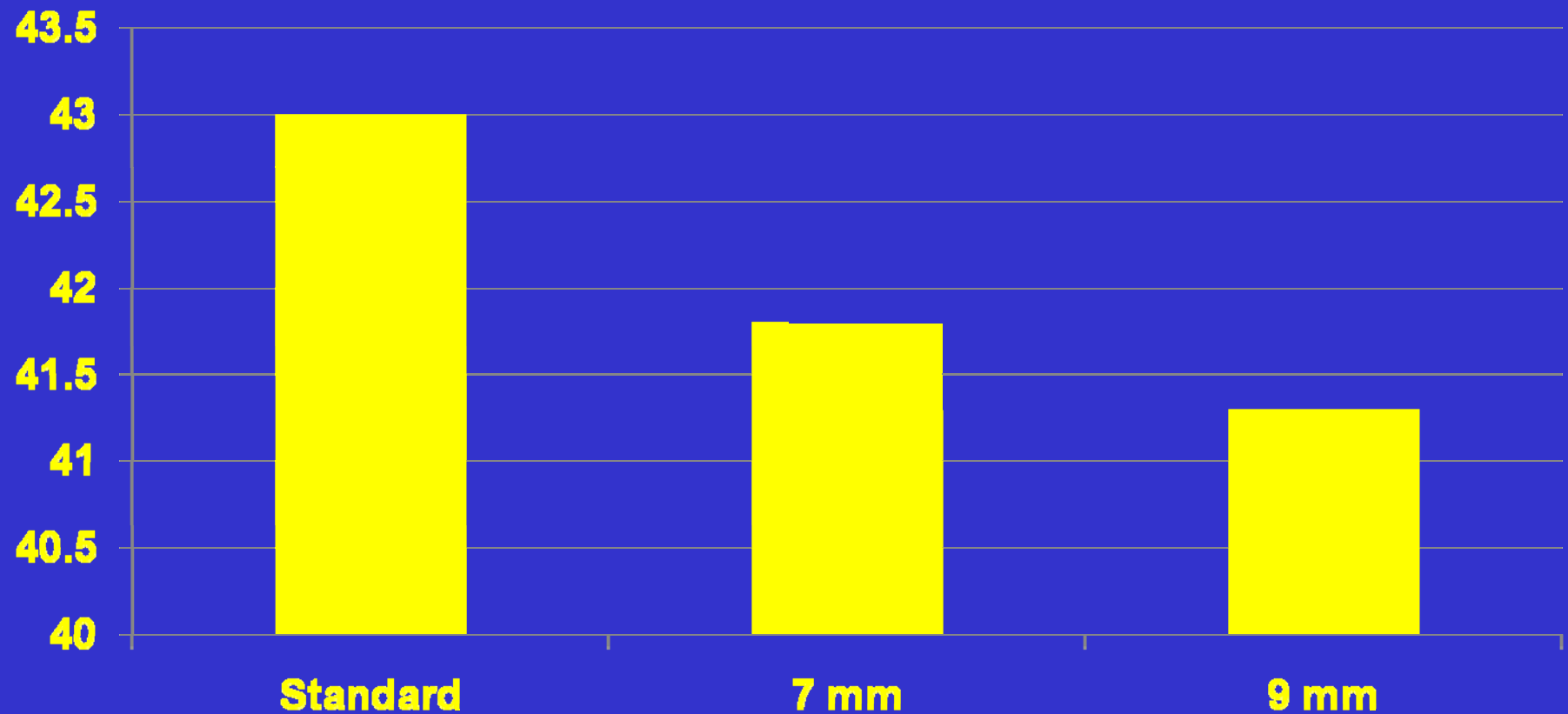

Summary

- **There are some significant improvements in the efficiency of weeding that can be achieved by employing cultivation systems that remove a greater percentage of weeds from the seedline**
- **The strategies may be scale specific**