

Irrigation Basics and Breakthroughs

Larry Schwankl

Irrigation Specialist

UC Cooperative Extension

559-646-6569

schwankl@uckac.edu

Presentation at: <http://ucanr.org/schwankl>

**Rainfall - Fresno, CA
2012 vs. Average**

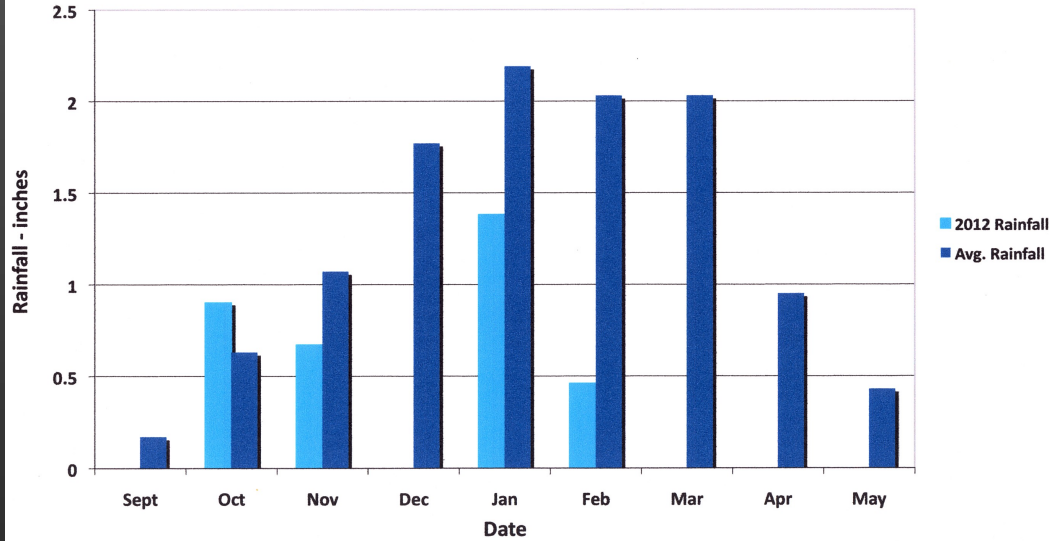

**We are currently at
about 45% of normal**

**2012 rainfall = 3.4”
Normal thru Feb. = 7.9”**

**Cumulative Rainfall - Fresno, CA
2012 vs. Average**

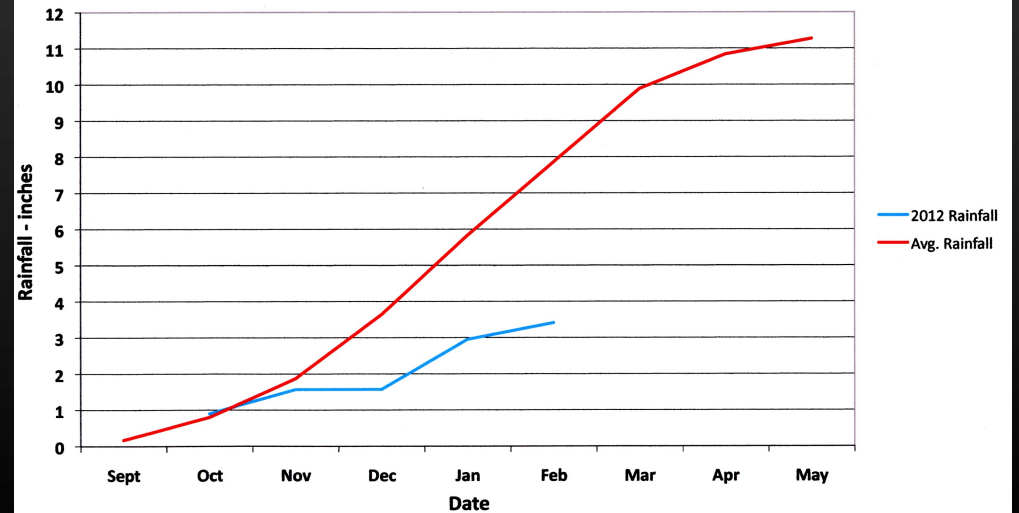



CONDITIONS FOR MAJOR RESERVOIRS: 20-FEB-2012

Data as of Midnight: 20-Feb-2012

Change Date: 20-Feb-2012

Refresh Da

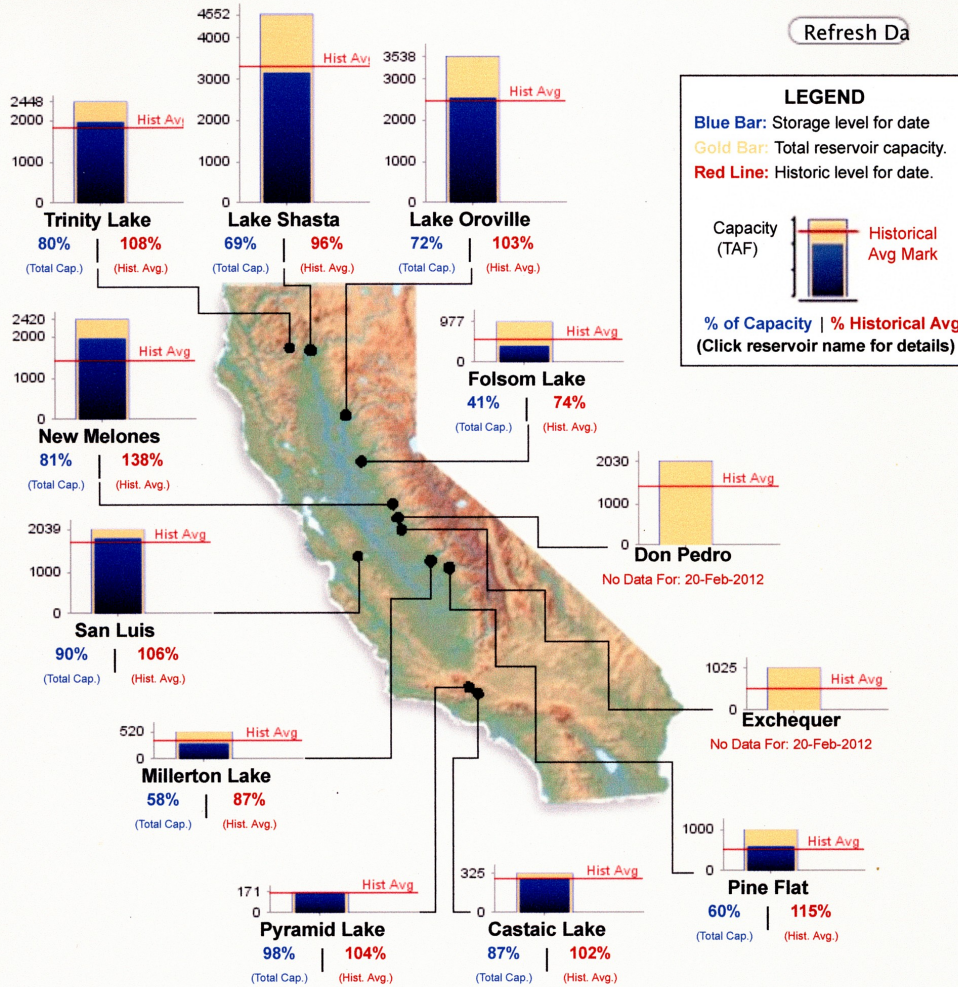

[Click for printable version of current data.](#)

Report Generated: 21-Feb-2012 9:20 AM

Snowpack = around
30% of normal

What can you do in your landscape to save water?

1. Irrigate the landscape you have as efficiently as you can.
 - When you start paying attention, you will do better.



What can you do in your landscape to save water?

1. Irrigate the landscape you have as efficiently as you can.
 - When you start paying attention, you will do better.
2. Change your landscape - change plant selection & irrigation system to be more water efficient.

Look for “Targets of Opportunity” to Save Water

1. Sprinklers are often good candidates - a lot of water can be lost to runoff down the gutter.



Look for “Targets of Opportunity” to Save Water

1. Sprinklers are often good candidates - a lot of water can be lost to runoff.
2. Turf & deciduous trees are often big water users.
 - Turf is large user and is sprinkler irrigated.

Look for “Targets of Opportunity” to Save Water

1. Sprinklers are often good candidates - a lot of water can be lost to runoff.
2. Turf & deciduous trees are often big water users.
 - Turf is large user and is sprinkler irrigated.
 - Water use reduced by being more efficient or getting rid of turf area.



Turfgrass Irrigation - Saving water:

- Don't irrigate so entire lawn is green & lush.
 - Back off on irrigation until see stressed areas in lawn. Irrigate those periodically by hand.



Turfgrass Irrigation - Saving water:

- Don't irrigate so entire lawn is green & lush.
- Reduce the water lost to runoff.
 - Time when runoff starts = station run time.
 - If need more irrigation time, cycle on and off
 - Wait at least 1 hour between irrigations.

Turfgrass Irrigation - Saving water:

- Don't irrigate so entire lawn is green & lush.
- **Reduce the water lost to runoff.**
 - Time when runoff starts = station run time.
 - If need more irrigation time, cycle on and off
 - Wait at least 1 hour between irrigations.
 - Adjust the sprinklers so don't water sidewalks & driveways.



Turfgrass Irrigation - Saving water:

- Don't irrigate so entire lawn is green & lush.
- Reduce the water lost to runoff.
- Irrigate in the early morning.

Reduce evaporation



Turfgrass Irrigation - Saving water:

- Don't irrigate so entire lawn is green & lush.
- Reduce the water lost to runoff.
- Irrigate in the early morning.

Reduce evaporation
Visually check for
problems



Turfgrass Irrigation - Saving water:

- Don't irrigate so entire lawn is green & lush.
- Reduce the water lost to runoff.
- Irrigate in the early morning.
- Adjust your controller for changing water needs.



Smart Controllers

- Biggest thing happening in landscape irrigation now.



Smart Controllers

- An irrigation controller which *automatically* adjusts the irrigation run times based on *environmental conditions*.

Smart Controllers

- An irrigation controller which *automatically* adjusts the irrigation run times based on *environmental conditions*.

What environmental conditions?

Smart Controllers

- An irrigation controller which *automatically* adjusts the irrigation run times based on *environmental conditions*.

What environmental conditions?

- Soil moisture conditions
- Weather conditions

Smart Controller with Soil Moisture Feedback?

Types of **soil moisture feedback**:

1. You set the irrigation schedule & soil moisture feedback cancels the programmed irrigation if “irrigation is not needed”



Smart Controller with Soil Moisture Feedback?

Types of **soil moisture feedback**:

1. You set the irrigation schedule & soil moisture feedback cancels the programmed irrigation if “irrigation is not needed”.
2. Soil moisture feedback controls the irrigations. Turns it on when needed.



Smart Controller with Soil Moisture Feedback?

Weakness: Where do you place the soil moisture sensor?
Is it representative of the whole landscape?

ET = Evapotranspiration = Plant Water Use

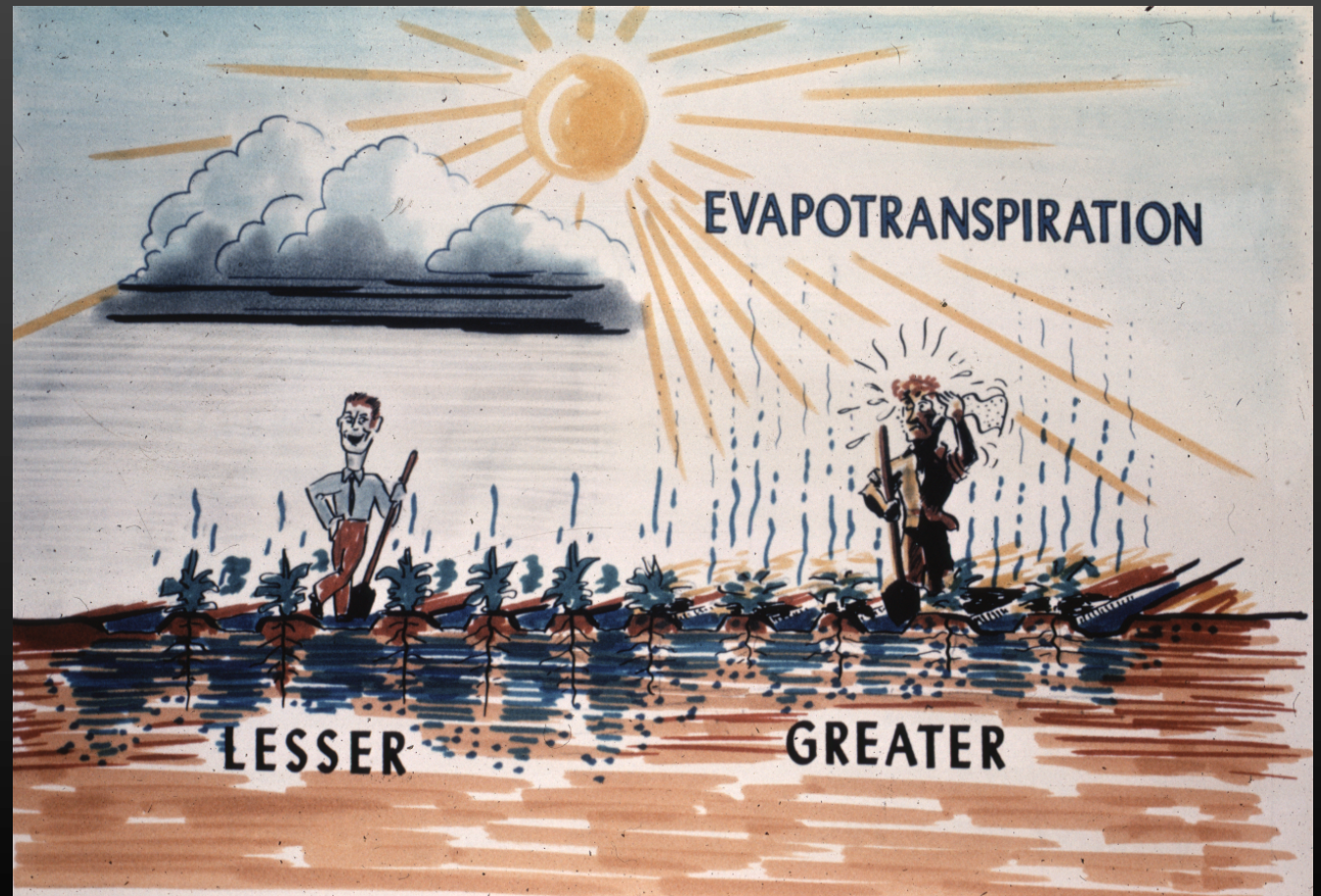

Smart Controller with Weather Conditions Feedback?

1. Historical ET info. in controller so that irrigation runtimes change as ET has changed historically. “Average” year.

Smart Controller with Weather Conditions Feedback?

1. **Historical ET info. in controller so that irrigation runtimes change as ET has changed historically. “Average” year.**
2. **Historical ET with adjustment from an on-site weather station.**

Smart Controller with Weather Conditions Feedback?

1. Historical ET info. in controller so that irrigation runtimes change as ET has changed historically. “Average” year.
2. Historical ET with adjustment from an on-site weather station.
3. **Controller uses on-site weather station to determine irrigation run times.**

Smart Controller with Weather Conditions Feedback?

1. Historical ET info. in controller so that irrigation runtimes change as ET has changed historically. “Average” year.
2. Historical ET with adjustment from an on-site weather station.
3. Controller uses on-site weather station to determine irrigation run times.
4. **Controller hooked into a wireless system which “beams” info. to controller.**
 - **Some hooked in so you can input / access data via the internet.**
 - **Initial costs + annual subscription**

Smart Controller with Weather Conditions Feedback?

Weakness: Is the weather info. the decisions are based on representative of what your landscape is experiencing?

- Weather station citing.
- Measurement instrument accuracy / reliability.
- **Conversion of weather info. to landscape plant ET.**

Smart Controller: Use them?

- **For turf, they should be beneficial.**
- **For mixed landscapes, difficult to use.**

Turfgrass Irrigation Management:

- How long to run the sprinklers?
 - Depends on:
 1. Time of year.
 2. Sprinkler application rate.

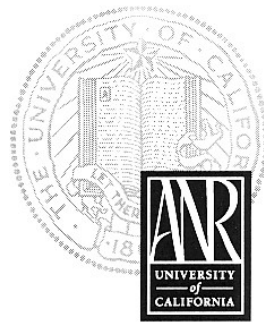

UNIVERSITY OF CALIFORNIA
Agriculture
and Natural Resources
<http://anrcatalog.ucdavis.edu>

PUBLICATION 8044

Lawn Watering Guide for California

Janet Hartin is UC Cooperative Extension Farm Advisor in Environmental Horticulture for San Bernardino County; **Pamela M. Geisel** is UCCE Farm Advisor in Environmental Horticulture for Fresno County; and **Carolyn L. Unruh** is a UCCE staff writer for Fresno County. This publication is adapted from "Dry Wit," a 1993 informational brochure published by the University of California, Division of Agriculture and Natural Resources.

The techniques described in this publication will help homeowners set up timed irrigation controllers for home lawns. The simple procedure involves identifying your home's climatic region, the type of turfgrass you have, and the output of your irrigation system. A set of tables provides a general guideline for scheduling lawn irri-

Turfgrass Irrigation Management:

- How long to run the sprinklers?

Region 5: San Joaquin Valley

Warm-Season Turfgrasses

Minutes per week to irrigate if
your hourly sprinkler output is:

	0.5 in	1.0 in	1.5 in	2.0 in
JAN	19	09	06	05
FEB	38	19	13	09
MAR	69	35	23	17
APR	101	50	34	25
MAY	132	66	44	33
JUN	164	82	55	41
JUL	170	85	57	43
AUG	145	72	48	36
SEP	113	57	38	28
OCT	69	35	23	17
NOV	32	16	11	08
DEC	13	06	04	03

Cool-Season Turfgrasses

Minutes per week to irrigate if
your hourly sprinkler output is:

	0.5 in	1.0 in	1.5 in	2.0 in
JAN	25	13	08	06
FEB	50	25	17	13
MAR	92	46	31	23
APR	134	67	45	34
MAY	176	88	59	44
JUN	218	109	73	55
JUL	227	113	76	57
AUG	193	97	64	48
SEP	151	76	50	38
OCT	92	46	31	23
NOV	42	21	14	11
DEC	17	08	06	04

Turfgrass Irrigation Management:

- Sprinkler application rate:
 - Set out some “catch cans” to determine your application rate.

5-foot catch can spacing
15 min run time

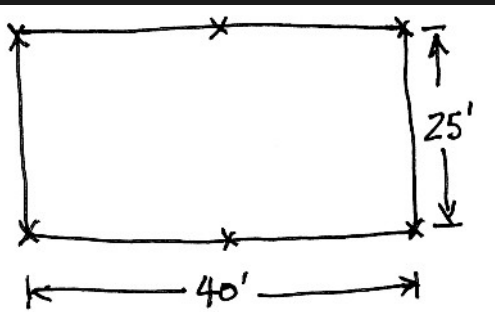

Turfgrass Irrigation Management:

- Sprinkler application rate:
 - Set out some “catch cans” to determine your application rate.

Measure the amount
of water collected



Turfgrass Irrigation Management:

Catch can test

Inches per hour

Average = 0.52 in/hr

X SPRINKLER	0.29	0.47	0.26	X SPRINKLER
0.44	0.44	0.61	0.23	0.29
0.64	0.87	0.55	0.26	0.23
0.73	0.67	0.55	0.26	0.32
0.93	1.28	0.70	0.35	0.35
X SPRINKLER	0.23	0.49	1.14	X SPRINKLER

Turfgrass Irrigation Management:

- Sprinkler application = 0.52 in/hr

Region 5: San Joaquin Valley

Warm-Season Turfgrasses

Minutes per week to irrigate if
your hourly sprinkler output is:

	0.5 in	1.0 in	1.5 in	2.0 in
JAN	19	09	06	05
FEB	38	19	13	09
MAR	69	35	23	17
APR	101	50	34	25
MAY	132	66	44	33
JUN	164	82	55	41
JUL	170	85	57	43
AUG	145	72	48	36
SEP	113	57	38	28
OCT	69	35	23	17
NOV	32	16	11	08
DEC	13	06	04	03

Cool-Season Turfgrasses

Minutes per week to irrigate if
your hourly sprinkler output is:

	0.5 in	1.0 in	1.5 in	2.0 in
JAN	25	13	08	06
FEB	50	25	17	13
MAR	92	46	31	23
APR	134	67	45	34
MAY	176	88	59	44
JUN	218	109	73	55
JUL	227	113	76	57
AUG	193	97	64	48
SEP	151	76	50	38
OCT	92	46	31	23
NOV	42	21	14	11
DEC	17	08	06	04

Turfgrass Irrigation - Saving water:

- Don't irrigate so entire lawn is green & lush.
- Reduce the water lost to runoff.
- Irrigate in the early morning.
- Adjust your controller for changing water needs.
- Try to avoid daily irrigations.
 - Odd/even watering requirements.



Turfgrass Irrigation - Saving water:

- Don't irrigate so entire lawn is green & lush.
- Reduce the water lost to runoff.
- Irrigate in the early morning.
- Adjust your controller for changing water needs.
- Try to avoid daily irrigations.
- Make sure sprinklers pop up above the grass.



Drip Irrigation:

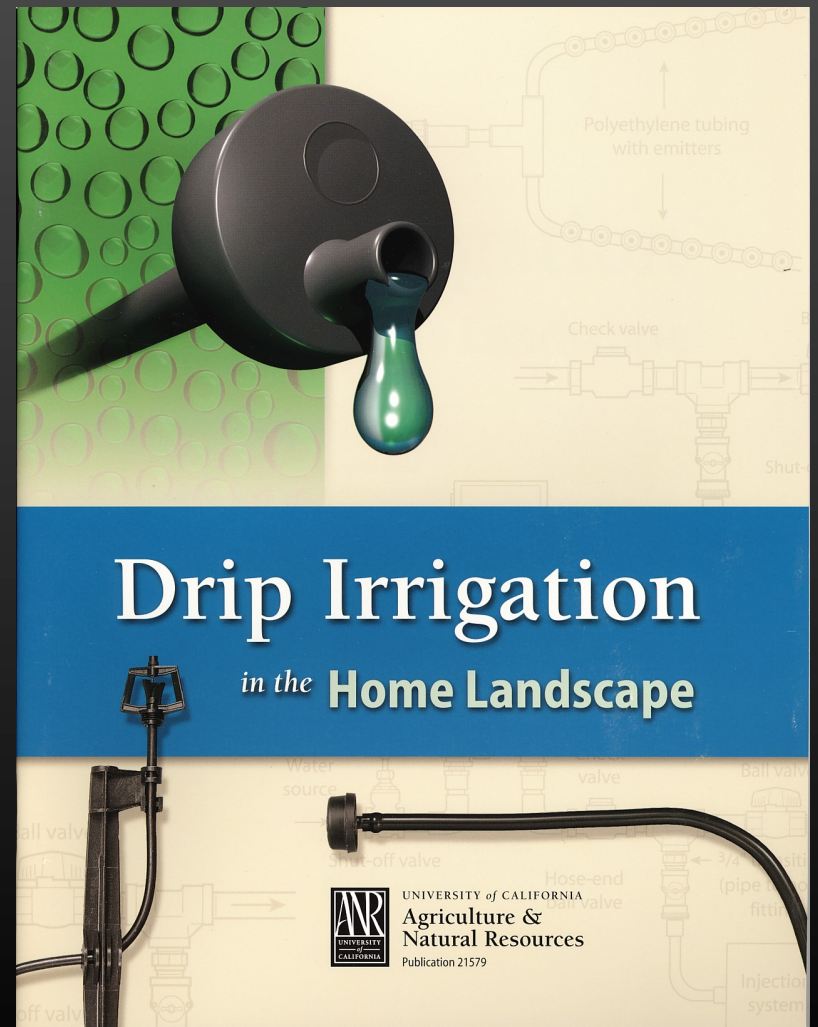

Drip Irrigation:

- Break the watering areas into “hydrozones”.
- Areas / plants of similar watering needs.



Drip Irrigation:

- Break the watering areas into “hydrozones”.
 - Areas / plants of similar watering needs.
- Plan ahead!!!
 - More zones are better (valves & controller).
 - You’ ll always want more zones / stations in the future.
 - New systems - don’ t skimp on underground pipe - harder to add later.

Drip Irrigation:

- Drip emitters for smaller, stand-alone plants.
 - 0.5 gph, 1 gph, 2 gph emitters available.

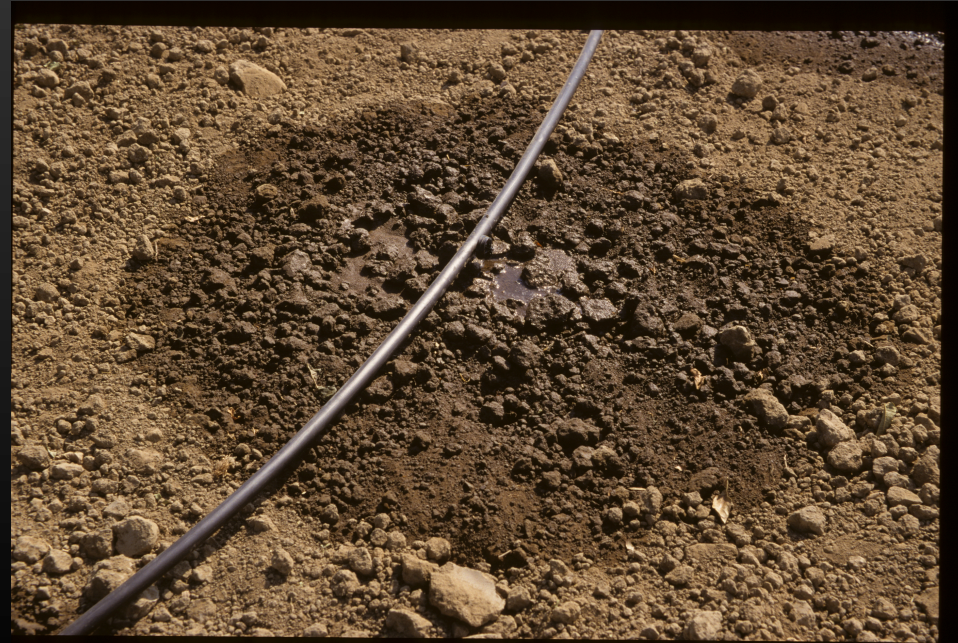

Drip Irrigation:

- Drip emitters for smaller, stand-alone plants.
- Sprayers / microsprinklers for larger plants (e.g. trees).



Drip Irrigation:

- Drip emitters for smaller, stand-alone plants.
- Sprayers / microsprinklers for larger plants (e.g. large trees).
- Narrow plantings, vegetable gardens.



Misc. Drip Irrigation Hints:

- Always use a filter.

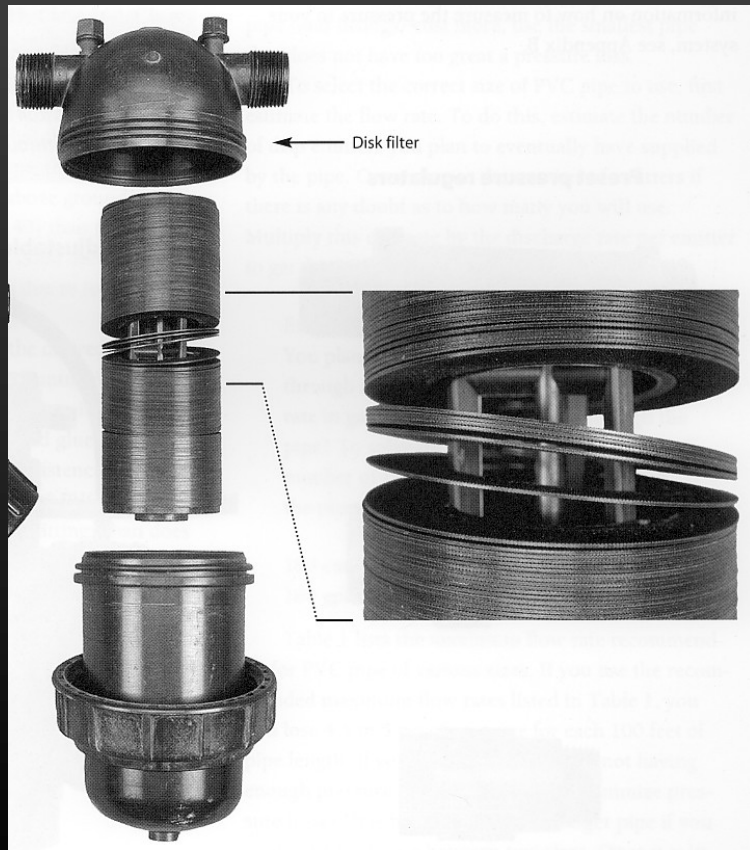

Misc. Drip Irrigation Hints:

- Always use a filter.
And **CLEAN IT** when it's dirty.

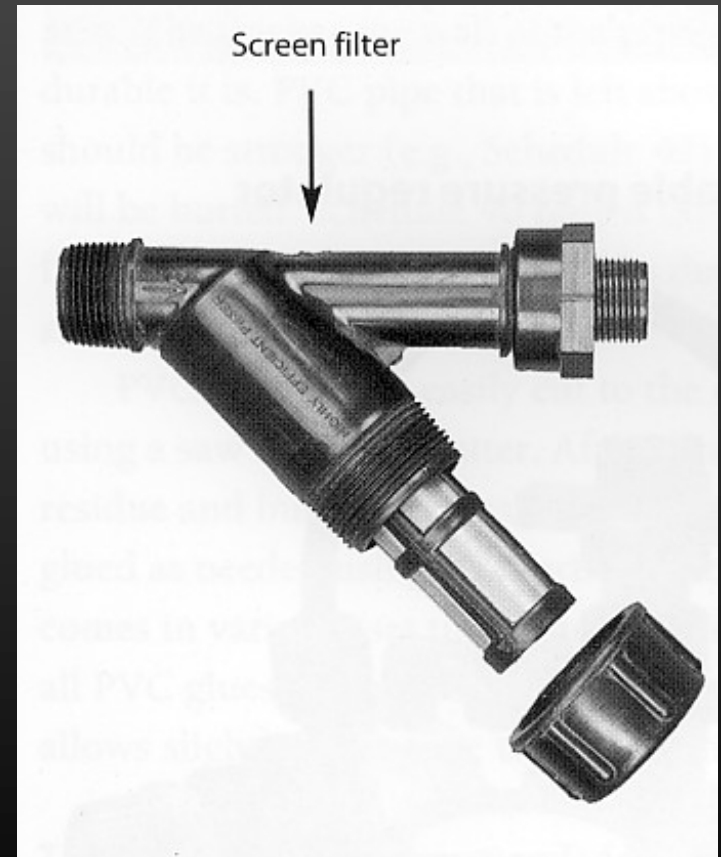
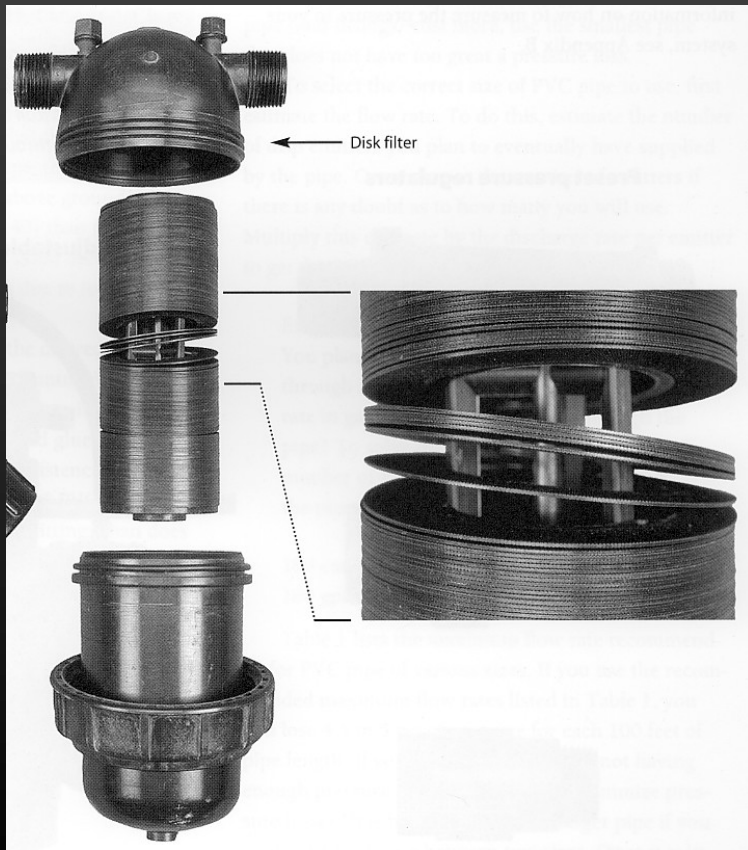

Misc. Drip Irrigation Hints:

- Always use a filter.
- Drip emitters shouldn't be buried.
- OK to put them under a mulch



Misc. Drip Irrigation Hints:

- Always use a filter.
- Drip emitters shouldn't be buried.
- Put drip line (without emitters) below ground when you can.



Misc. Drip Irrigation Hints:

- Always use a filter.
- Drip emitters shouldn't be buried.
- Put drip line (without emitters) below ground when you can.
- You can put quite a few (e.g. 200) drip emitters on a drip line.



Misc. Drip Irrigation Hints:

- Always use a filter.
- Drip tubing / fittings come in different sizes.
- Use pressure reducers to lower the pressure.
- Drip emitters shouldn't be buried.
- Put drip line (without emitters) below ground when you can.
- You can put quite a few (e.g. 200) drip emitters on a drip line.
- **Slow application rate with drip irrigation = may require long station run times.**



Misc. Drip Irrigation Hints:

- Always use a filter.
- Drip tubing / fittings come in different sizes.
- Use pressure reducers to lower the pressure.
- Drip emitters shouldn't be buried.
- Put drip line (without emitters) below ground when you can.
- You can put quite a few (e.g. 200) drip emitters on a drip line.
- Slow application rate with drip irrigation = may require long station run times.
- **Daily irrigations are not preferred (usually) - water deep**
 - Check the soil if in doubt



Misc. Drip Irrigation Hints:

- Always use a filter.
- Drip tubing / fittings come in different sizes.
- Use pressure reducers to lower the pressure.
- Drip emitters shouldn't be buried.
- Put drip line (without emitters) below ground when you can.
- You can put quite a few (e.g. 200) drip emitters on a drip line.
- Slow application rate with drip irrigation = may require long station run times.
- Daily irrigations are not preferred (usually) - water deep
- Plant symptoms for under-watering & over-watering often look similar.
 - Check the soil



Questions?



Larry Schwankl

559-646-6569

[e-mail: schwankl@uckac.edu](mailto:schwankl@uckac.edu)

Presentation available at: <http://ucanr.org/schwankl>